

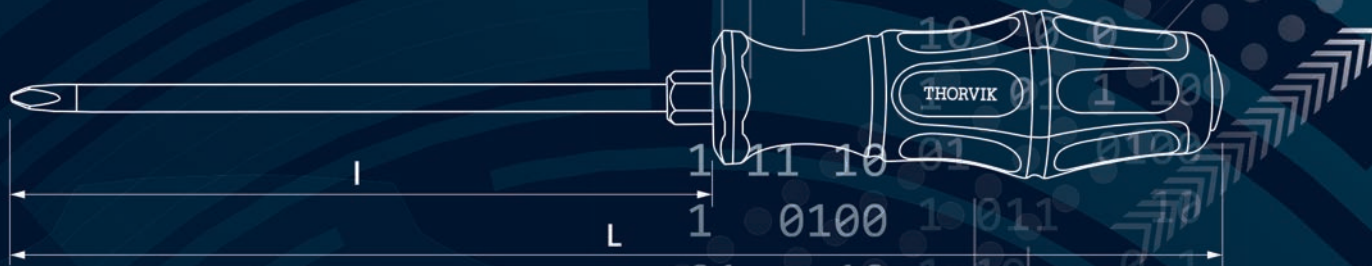

THORVIK®

RELIABLE TOOLS



CATALOG 2021

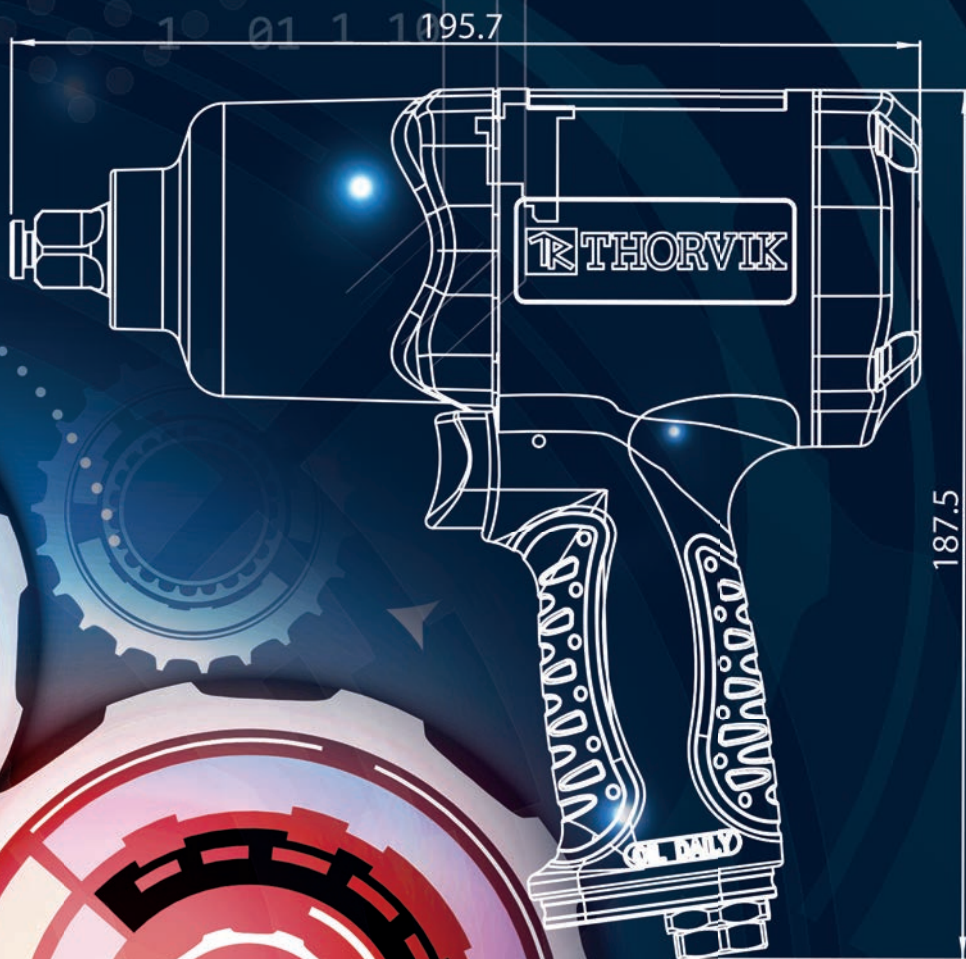

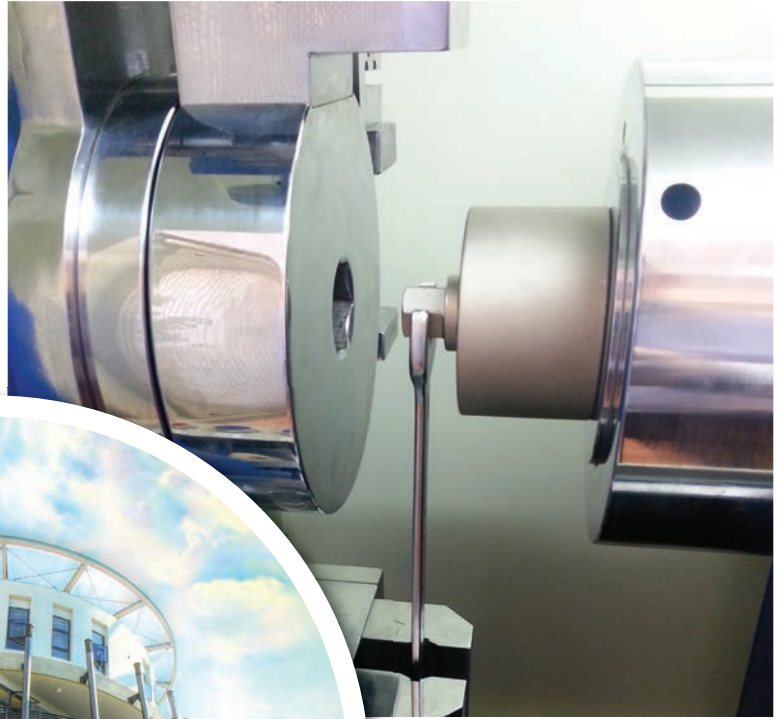





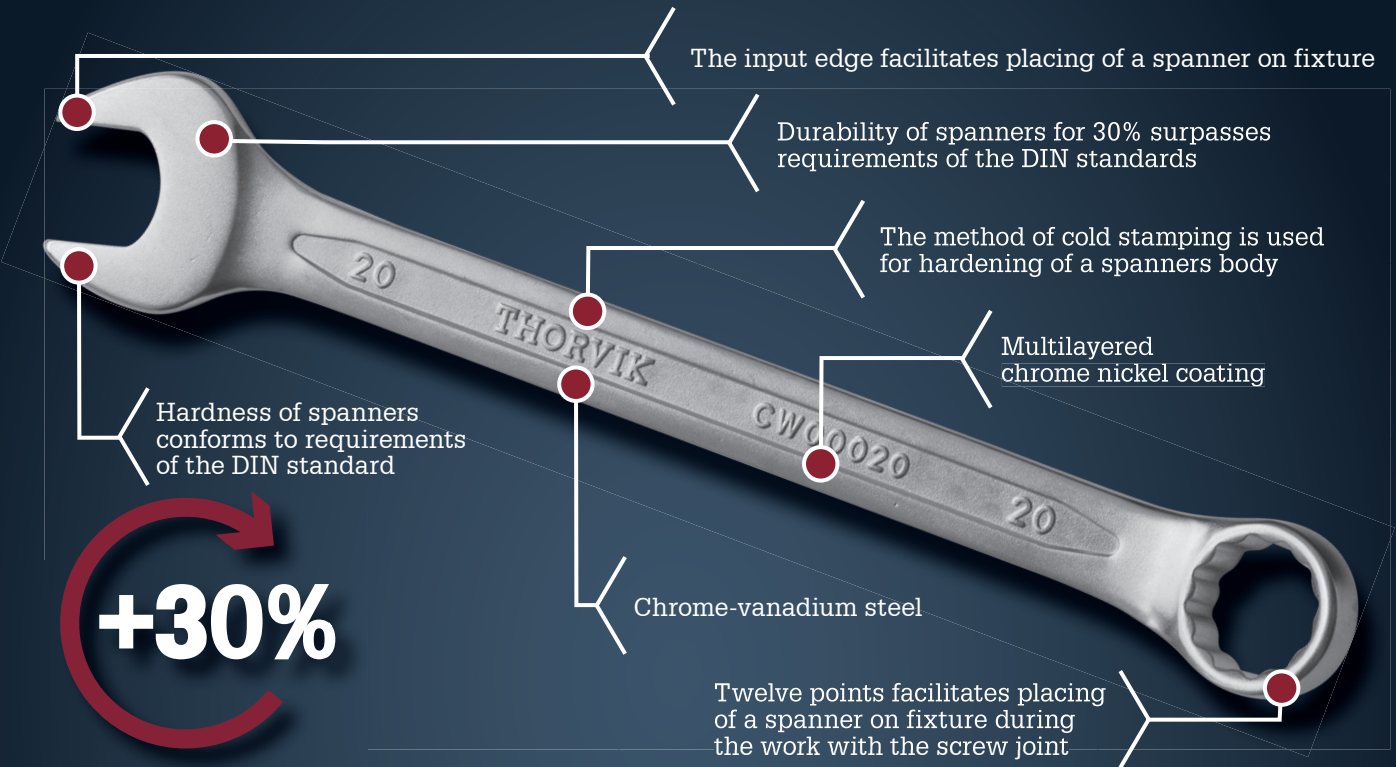

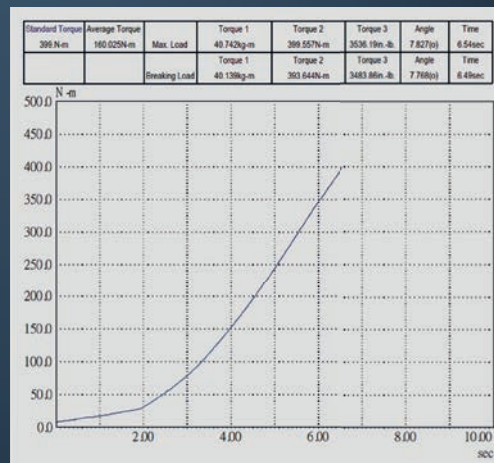
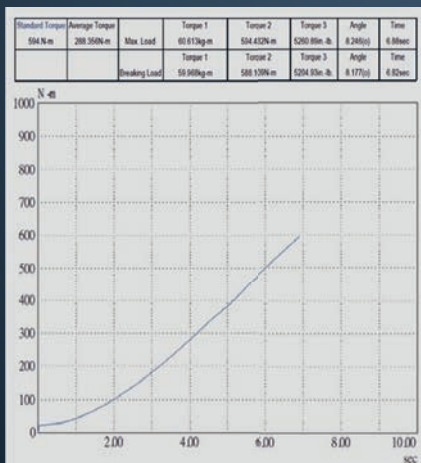

Spanners

THORVIK® spanners are produced of modern materials and under the technologies meeting strict requirements of the international standards. Habitual double-T section of handles, electroplated coating, steady against aggressive and mechanical influences, a variety of scopes, width of a size range, convenient storage of sets, reliability and durability makes the THORVIK® tools the worthy assistant to the operator.



Test reports:



| | | | | |
|---|---|--|---|--|
| Cr-V Chrome-vanadium steel | DIN According to DIN standards | DIN5234 Form A According to DIN5234 Form A |  Adjustable working part | DIN5234 Form C According to DIN5234 Form C |
| 12 Ring part |  Open end part |  Flare nut | 45° The angle of the working surfaces - 45° |  Grip type |
|  Shape cuts working parts | TYPE F The shape of the jaws of the working part is straight | TYPE S The shape of the jaws of the working part is curved | 90° The angle of the working surfaces - 90° | |
|  Weight of one item |  Quantity in the package / shipping box |  Packing weight (gross) / shipping box (gross) | | |

COMBINATION WRENCHES AND SETS OF THEM

The most widespread and popular type of a wrench combining open-end and ring-end characteristics in a design. Use of two one-dimensional profiles does the tool universal in use. Wrenches are made of the alloyed chrome-vanadium steel according to the DIN 3113 standard.

Combination wrenches

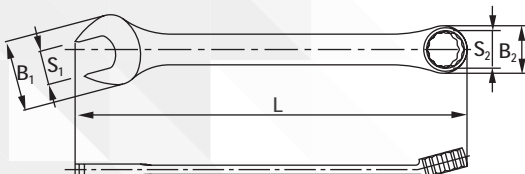

| Code | Item No. | S1=S2, mm | B1, mm | B2, mm | L, mm | kg | pcs | kg |
|-------|----------|-----------|--------|--------|-------|-------|---------|---------|
| 52020 | CW00006 | 6 | 15 | 10 | 100 | 0,015 | 100/800 | 1,60/14 |
| 52021 | CW00007 | 7 | 16 | 11 | 110 | 0,02 | 100/800 | 2,10/18 |
| 52022 | CW00008 | 8 | 18 | 13 | 115 | 0,025 | 100/600 | 2,70/17 |
| 52023 | CW00009 | 9 | 20 | 14 | 125 | 0,03 | 100/600 | 3,20/21 |
| 52024 | CW00010 | 10 | 22 | 15 | 135 | 0,35 | 100/400 | 3,80/16 |
| 52025 | CW00011 | 11 | 24 | 17 | 145 | 0,45 | 50/300 | 2,30/15 |
| 52026 | CW00012 | 12 | 26 | 18 | 155 | 0,06 | 50/300 | 2,90/18 |
| 52027 | CW00013 | 13 | 28 | 19 | 165 | 0,07 | 50/300 | 3,70/23 |
| 52028 | CW00014 | 14 | 30 | 21 | 172 | 0,08 | 50/200 | 4,00/17 |
| 52029 | CW00015 | 15 | 32 | 22 | 185 | 0,1 | 50/200 | 5,00/21 |
| 52030 | CW00016 | 16 | 33 | 24 | 194 | 0,115 | 50/200 | 5,75/24 |
| 52031 | CW00017 | 17 | 35 | 25 | 210 | 0,125 | 50/200 | 6,30/26 |
| 52032 | CW00018 | 18 | 37 | 27 | 219 | 0,15 | 25/100 | 3,75/16 |
| 52033 | CW00019 | 19 | 40 | 28 | 229 | 0,16 | 25/100 | 4,00/17 |
| 52034 | CW00020 | 20 | 42 | 29 | 240 | 0,183 | 25/100 | 4,50/19 |
| 52035 | CW00021 | 21 | 43 | 30 | 244 | 0,205 | 25/100 | 5,00/21 |
| 52036 | CW00022 | 22 | 45 | 32 | 248 | 0,215 | 25/100 | 5,50/23 |
| 52037 | CW00023 | 23 | 47 | 34 | 258 | 0,245 | 10/80 | 2,63/22 |
| 52038 | CW00024 | 24 | 49 | 35 | 269 | 0,26 | 10/80 | 2,63/22 |
| 52039 | CW00025 | 25 | 50 | 36 | 281 | 0,285 | 10/60 | 3,20/20 |
| 52040 | CW00026 | 26 | 53 | 38 | 288 | 0,3 | 10/60 | 3,50/22 |
| 52041 | CW00027 | 27 | 54 | 39 | 298 | 0,35 | 10/60 | 3,50/22 |
| 52042 | CW00028 | 28 | 56 | 40 | 308 | 0,37 | 10/40 | 4,50/19 |
| 52043 | CW00030 | 30 | 60 | 42 | 328 | 0,435 | 10/40 | 4,50/19 |
| 52044 | CW00032 | 32 | 63 | 45 | 348 | 0,56 | 10/40 | 5,75/24 |

Combination wrench sets

Combination wrench sets in bags

14 pcs



16 pcs



| Code | Item No. | kg | pcs | kg |
|--|----------|------|-----|---------|
| 52047 | CWS0014 | 2,75 | 1/8 | 2,75/25 |
| Content: 10, 11, 12, 13, 14, 16, 17, 19, 21, 22, 24, 27, 30, 32 mm | | | | |

| Code | Item No. | kg | pcs | kg |
|--|----------|------|------|---------|
| 52048 | CWS0016 | 1,50 | 1/12 | 1,50/21 |
| Content: 6, 7, 8, 9, 10, 11, 12, 13, 14, 15, 16, 17, 18, 19, 22, 24 mm | | | | |

25 pcs

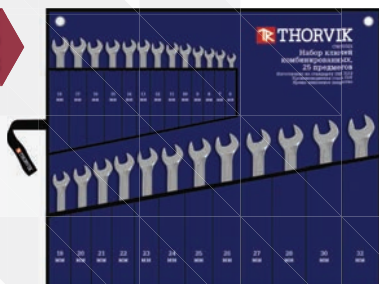

| Code | Item No. | kg | pcs | kg |
|--|----------|------|-----|---------|
| 52049 | CWS0025 | 4,50 | 1/4 | 4,50/20 |
| Content: 6, 7, 8, 9, 10, 11, 12, 13, 14, 15, 16, 17, 18, 19, 20, 21, 22, 23, 24, 25, 26, 27, 28, 30, 32 mm | | | | |

Combination wrenches set on a plastic holder



| Code | Item No. | kg | pcs | kg |
|--|----------|------|------|---------|
| 52045 | CWS0008 | 0,63 | 4/24 | 2,50/19 |
| Content: 8, 9, 10, 12, 13, 14, 17, 19 mm | | | | |



| Code | Item No. | kg | pcs | kg |
|---|----------|------|------|---------|
| 52046 | CWS0012 | 1,00 | 4/16 | 4,00/21 |
| Content: 6, 7, 8, 10, 12, 13, 14, 15, 16, 17, 19, 22 mm | | | | |

Combination wrenches "ARC"

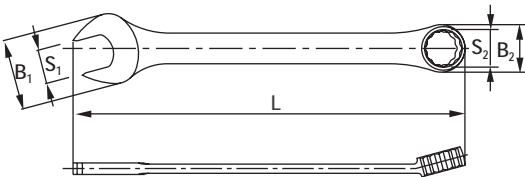

| Code | Item No. | S1=S2, mm | B1, mm | B2, mm | L, mm | kg | pcs | kg |
|-------|----------|-----------|--------|--------|--------|-------|-----|------|
| 52515 | W30006 | 6 | 14,80 | 10,70 | 100,00 | 0,020 | 500 | 11,4 |
| 52516 | W30007 | 7 | 15,95 | 12,20 | 109,00 | 0,025 | 500 | 13,8 |
| 52517 | W30008 | 8 | 18,35 | 12,90 | 119,00 | 0,028 | 500 | 15,1 |
| 52518 | W30009 | 9 | 20,40 | 14,30 | 129,00 | 0,034 | 500 | 18,2 |
| 52519 | W30010 | 10 | 22,35 | 15,50 | 139,00 | 0,041 | 400 | 17,2 |
| 52520 | W30011 | 11 | 25,50 | 17,35 | 149,00 | 0,048 | 300 | 16,2 |
| 52521 | W30012 | 12 | 27,00 | 18,70 | 159,00 | 0,062 | 300 | 19,8 |
| 52522 | W30013 | 13 | 27,10 | 19,80 | 168,00 | 0,078 | 250 | 20,9 |
| 52523 | W30014 | 14 | 30,90 | 21,75 | 179,00 | 0,085 | 200 | 19,2 |
| 52524 | W30015 | 15 | 32,10 | 22,10 | 189,00 | 0,094 | 150 | 16,5 |
| 52525 | W30016 | 16 | 35,10 | 23,70 | 199,00 | 0,115 | 100 | 12,5 |
| 52526 | W30017 | 17 | 37,20 | 25,60 | 209,00 | 0,128 | 100 | 14,2 |
| 52527 | W30018 | 18 | 38,65 | 26,80 | 219,00 | 0,145 | 100 | 15,7 |
| 52528 | W30019 | 19 | 40,80 | 28,65 | 229,00 | 0,162 | 100 | 17,9 |
| 52529 | W30020 | 20 | 42,85 | 29,70 | 238,00 | 0,162 | 100 | 17,9 |
| 52530 | W30021 | 21 | 45,40 | 31,65 | 248,00 | 0,215 | 75 | 18,2 |
| 52531 | W30022 | 22 | 46,95 | 32,10 | 259,00 | 0,240 | 50 | 13,4 |
| 52532 | W30023 | 23 | 46,45 | 31,95 | 259,00 | 0,250 | 50 | 13,5 |
| 52533 | W30024 | 24 | 51,10 | 34,25 | 275,00 | 0,290 | 50 | 15,6 |
| 52534 | W30025 | 25 | 52,30 | 35,75 | 280,00 | 0,330 | 50 | 18,5 |
| 52535 | W30026 | 26 | 54,30 | 37,70 | 290,00 | 0,356 | 50 | 19,1 |
| 52536 | W30027 | 27 | 56,40 | 40,10 | 309,00 | 0,435 | 40 | 18,2 |
| 52537 | W30028 | 28 | 57,00 | 41,25 | 324,00 | 0,460 | 40 | 18,9 |
| 52631 | W30029 | 29 | 60,00 | 43,00 | 335,00 | 0,493 | 40 | 20,7 |
| 52538 | W30030 | 30 | 61,90 | 42,65 | 336,00 | 0,527 | 30 | 16,8 |
| 52539 | W30032 | 32 | 63,70 | 45,95 | 346,00 | 0,600 | 30 | 19 |
| 52540 | W30034 | 34 | 67,24 | 49,83 | 426,20 | 0,900 | 20 | 18,5 |
| 52541 | W30036 | 36 | 67,24 | 49,83 | 425,50 | 1,280 | 10 | 13,4 |
| 52542 | W30038 | 38 | 72,87 | 55,23 | 480,60 | 1,100 | 10 | 11,7 |
| 52543 | W30041 | 41 | 72,20 | 56,72 | 479,70 | 1,450 | 10 | 15,1 |
| 52544 | W30046 | 46 | 96,44 | 70,77 | 585,10 | 1,780 | 10 | 18,4 |
| 52545 | W30050 | 50 | 96,44 | 70,60 | 587,10 | 2,180 | 5 | 11,4 |

Set of combination wrenches "ARC"

Set of combination wrenches "ARC" on a plastic holder



| Code | Item No. | kg | pcs | kg |
|-----------------------------------|----------|-------|-----|------|
| 52611 | W3S6PR | 0,467 | 30 | 14,7 |
| Content: 8, 10, 12, 13, 14, 17 mm | | | | |

8 pcs



9 pcs



| Code | Item No. | kg | pcs | kg |
|--|----------|-------|-----|------|
| 52612 | W3S8PR | 0,670 | 20 | 14,1 |
| Content: 6, 8, 10, 12, 13, 14, 17, 19 mm | | | | |

| Code | Item No. | kg | pcs | kg |
|---|----------|-------|-----|------|
| 52613 | W3S9PR | 0,985 | 20 | 20,5 |
| Content: 8, 10, 12, 13, 14, 15, 17, 19, 22 mm | | | | |

10 pcs



12 pcs



| Code | Item No. | kg | pcs | kg |
|---|----------|-------|-----|------|
| 52627 | W3S10PR | 0,815 | 20 | 17,1 |
| Content: 6, 7, 8, 10, 12, 13, 14, 15, 17, 19 mm | | | | |

| Code | Item No. | kg | pcs | kg |
|--|----------|-------|-----|----|
| 52605 | W3S12PR | 1,040 | 10 | 11 |
| Content: 6, 7, 8, 9, 10, 11, 12, 13, 14, 17, 19, 22 mm | | | | |

Combination wrench sets "ARC" series in a bags

12 pcs

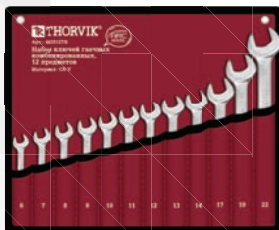

12 pcs



| Code | Item No. | kg | pcs | kg |
|--|----------|-------|-----|------|
| 52606 | W3S12TB | 1,030 | 10 | 11,5 |
| Content: 6, 7, 8, 9, 10, 11, 12, 13, 14, 17, 19, 22 mm | | | | |

| Code | Item No. | kg | pcs | kg |
|--|----------|-------|-----|------|
| 52604 | W3S12ETB | 1,290 | 10 | 14,1 |
| Content: 6, 8, 10, 12, 13, 14, 15, 16, 17, 18, 19, 22 mm | | | | |

16 pcs



20 pcs

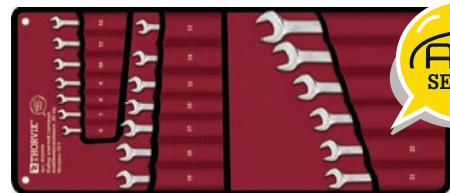

| Code | Item No. | kg | pcs | kg |
|--|----------|-------|-----|------|
| 52607 | W3S16TB | 1,720 | 10 | 18,7 |
| Content: 6, 7, 8, 9, 10, 11, 12, 13, 14, 15, 16, 17, 18, 19, 22, 24 mm | | | | |

| Code | Item No. | kg | pcs | kg |
|--|----------|-------|-----|------|
| 52608 | W3S20TB | 3,600 | 4 | 15,5 |
| Content: 6, 7, 8, 9, 10, 11, 12, 13, 14, 15, 16, 17, 18, 19, 21, 22, 24, 27, 30, 32 mm | | | | |

22 pcs

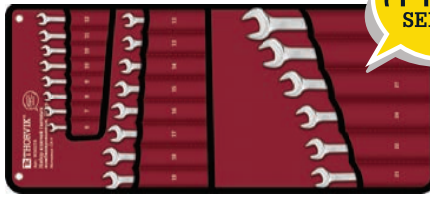

| Code | Item No. | kg | pcs | kg |
|--|----------|-------|-----|----|
| 52609 | W3S22TB | 3,725 | 4 | 16 |
| Content: 6, 7, 8, 9, 10, 10, 11, 12, 13, 13, 14, 15, 16, 17, 18, 19, 21, 22, 24, 27, 30, 32 mm | | | | |

26 pcs

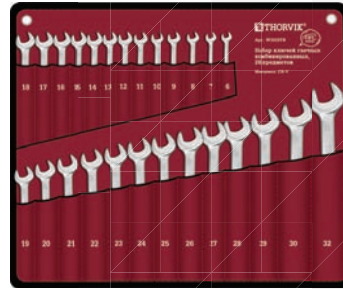

| Code | Item No. | kg | pcs | kg |
|--|----------|-------|-----|------|
| 52610 | W3S26TB | 5,650 | 2 | 12,3 |
| Content: 6, 7, 8, 9, 10, 11, 12, 13, 14, 15, 16, 17, 18, 19, 20, 21, 22, 23, 24, 25, 26, 27, 28, 29, 30, 32 mm | | | | |

Combination wrench SAE

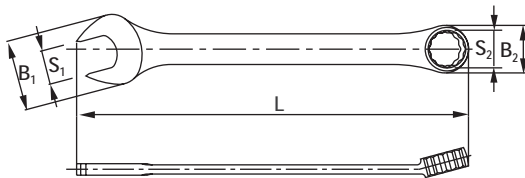

| Code | Item Number | S1=S2, | B1, mm | B2, mm | L, mm | kg | pcs | kg |
|-------|-------------|---------|--------|--------|-------|-------|----------|----------|
| 52902 | CWI0014 | 1/4" | 15,0 | 10,2 | 100 | 0,014 | 100/1200 | 1,4/16,8 |
| 52910 | CWI0516 | 5/16" | 18,0 | 13,0 | 120 | 0,023 | 100/800 | 2,3/18,4 |
| 52904 | CWI0038 | 3/8" | 22,0 | 15,8 | 140 | 0,036 | 100/400 | 3,6/14,4 |
| 52911 | CWI0716 | 7/16" | 24,5 | 17,2 | 150 | 0,045 | 100/400 | 4,5/18,0 |
| 52901 | CWI0012 | 1/2" | 28,5 | 20,0 | 170 | 0,065 | 50/300 | 3,2/19,5 |
| 52912 | CWI0916 | 9/16" | 30,5 | 21,5 | 180 | 0,071 | 50/200 | 3,5/14,2 |
| 52905 | CWI0058 | 5/8" | 34,5 | 24,0 | 200 | 0,096 | 25/200 | 2,4/19,2 |
| 52913 | CWI1116 | 11/16" | 37,5 | 25,5 | 210 | 0,112 | 25/150 | 2,8/16,8 |
| 52903 | CWI0034 | 3/4" | 42,0 | 28,0 | 230 | 0,162 | 25/100 | 4,0/16,2 |
| 52914 | CWI1316 | 13/16" | 45,0 | 31,5 | 250 | 0,209 | 25/100 | 5,2/20,9 |
| 52906 | CWI0078 | 7/8" | 47,0 | 33,0 | 260 | 0,221 | 25/100 | 5,5/22,1 |
| 52915 | CWI1516 | 15/16" | 51,0 | 36,0 | 280 | 0,286 | 10/80 | 2,9/22,9 |
| 52900 | CWI0001 | 1" | 53,5 | 37,0 | 290 | 0,307 | 10/60 | 3,1/18,4 |
| 52908 | CWI0116 | 1-1/16" | 57,5 | 39,5 | 310 | 0,376 | 10/60 | 3,8/22,6 |
| 52909 | CWI0118 | 1-1/8" | 59,5 | 42,5 | 330 | 0,436 | 10/40 | 4,4/17,4 |
| 52907 | CWI0114 | 1-1/4" | 65,5 | 46,5 | 360 | 0,524 | 10/40 | 5,2/21,0 |

Combination wrench sets SAE in bags

Combination wrench sets SAE 1/4"-15/16" in a bag

12 pcs



| Code | Item No. | kg | pcs | kg |
|--|----------|------|-----|------|
| 52916 | CWIS0012 | 1,34 | 10 | 20,4 |
| Content: 1/4", 5/16", 3/8", 7/16", 1/2", 9/16", 5/8", 11/16", 3/4", 13/16", 7/8", 15/16" | | | | |

Combination wrench sets SAE 1/4"-1.1/4" in a bag

16 pcs



| Code | Item No. | kg | pcs | kg |
|---|----------|------|-----|-------|
| 52917 | CWIS0016 | 2,98 | 4 | 16,93 |
| Content: 1/4", 5/16", 3/8", 7/16", 1/2", 9/16", 5/8", 11/16", 3/4", 13/16", 7/8", 15/16", 1", 1-1/16", 1-1/8", 1-1/4" | | | | |

OPEN END WRENCHES AND SETS OF THEM

Universal tool for maintenance fasteners, available only on one side. The tools are made of chrome-vanadium steel according to DIN 3110

Open end wrenches



Cr-V

DIN

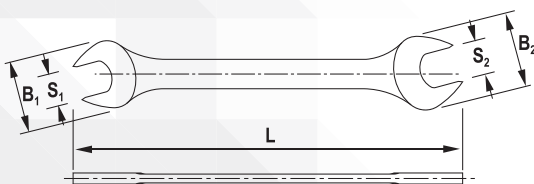

| Code | Item No. | S1xS2, mm | B1, mm | B2, mm | L, mm | kg | pcs | kg |
|-------|----------|-----------|--------|--------|-------|------|---------|---------|
| 52001 | OEW0607 | 6x7 | 16 | 17 | 125 | 0,02 | 100/800 | 2,30/20 |
| 52002 | OEW0810 | 8x10 | 19 | 23 | 142 | 0,04 | 100/600 | 3,40/22 |
| 52003 | OEW0911 | 9x11 | 21 | 25 | 155 | 0,05 | 100/400 | 5,00/21 |
| 52004 | OEW1213 | 12x13 | 27 | 29 | 168 | 0,07 | 50/300 | 3,10/20 |
| 52005 | OEW1417 | 14x17 | 30 | 36 | 202 | 0,13 | 50/200 | 5,40/25 |
| 52006 | OEW1922 | 19x22 | 41 | 48 | 232 | 0,20 | 25/100 | 5,20/22 |
| 52007 | OEW2427 | 24x27 | 51 | 55 | 262 | 0,31 | 10/60 | 2,85/19 |

Open end wrenches set

Open end wrenches set on a plastic holder

Open end wrenches set in a bag

6 pcs



7 pcs



| Code | Item No. | kg | pcs | kg |
|--|----------|------|------|---------|
| 52008 | OEWS006 | 0,54 | 4/24 | 2,15/17 |
| Content: 6x7, 8x10, 9x11, 12x13, 14x17, 19x22 mm | | | | |

| Code | Item No. | kg | pcs | kg |
|---|----------|------|------|---------|
| 52009 | OEWS007 | 0,88 | 1/24 | 0,88/24 |
| Content: 6x7, 8x10, 9x11, 12x13, 14x17, 19x22, 24x27 mm | | | | |



Open end wrenches. Series ARC



Cr-V

DIN

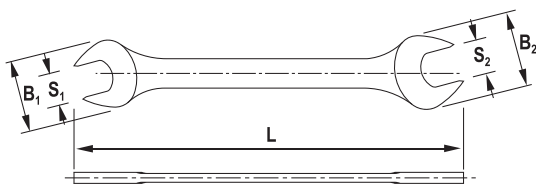

| Code | Item No. | S1xS2, mm | B1, mm | B2, mm | L, mm | kg | pcs | kg |
|-------|----------|-----------|--------|--------|-------|-------|-----|------|
| 52570 | W10607 | 6x7 | 10,6 | 12,5 | 178 | 0,023 | 500 | 12,6 |
| 52571 | W10809 | 8x9 | 13,1 | 14,8 | 187 | 0,03 | 500 | 16,1 |
| 52572 | W10810 | 8x10 | 13,5 | 15,1 | 187 | 0,03 | 500 | 16,1 |
| 52573 | W11011 | 10x11 | 15,7 | 17,7 | 198 | 0,05 | 300 | 16,1 |
| 52574 | W11012 | 10x12 | 15,7 | 17,7 | 198 | 0,05 | 300 | 16,1 |
| 52575 | W11013 | 10x13 | 17,1 | 19,2 | 220 | 0,066 | 200 | 15,1 |
| 52576 | W11213 | 12x13 | 19,4 | 20,4 | 220 | 0,066 | 200 | 15,1 |
| 52577 | W11314 | 13x14 | 22,6 | 23,6 | 228 | 0,093 | 200 | 19,5 |
| 52578 | W11317 | 13x17 | 25,6 | 26,9 | 242 | 0,124 | 150 | 19,6 |
| 52579 | W11415 | 14x15 | 22,1 | 23,2 | 224 | 0,093 | 200 | 19,5 |
| 52580 | W11416 | 14x16 | 21,9 | 22,6 | 228 | 0,093 | 200 | 19,5 |
| 52581 | W11417 | 14x17 | 25,6 | 26,9 | 242 | 0,124 | 150 | 19,6 |
| 52582 | W11617 | 16x17 | 24,7 | 25,9 | 242 | 0,124 | 150 | 19,6 |
| 52583 | W11719 | 17x19 | 27,3 | 27,7 | 262 | 0,142 | 100 | 16,1 |
| 52584 | W11819 | 18x19 | 27,3 | 27,7 | 262 | 0,142 | 100 | 16,1 |
| 52586 | W11922 | 19x22 | 30,7 | 33,9 | 288 | 0,199 | 75 | 16 |
| 52587 | W12022 | 20x22 | 30,7 | 33,9 | 288 | 0,199 | 75 | 16 |
| 52588 | W12123 | 21x23 | 31,0 | 33,9 | 292 | 0,231 | 75 | 18,1 |
| 52589 | W12224 | 22x24 | 30,5 | 33,8 | 292 | 0,231 | 75 | 18,1 |
| 52590 | W12427 | 24x27 | 35,4 | 40,2 | 319 | 0,298 | 50 | 15,8 |
| 52591 | W12528 | 25x28 | 37,6 | 41,0 | 362 | 0,376 | 50 | 19,7 |
| 52592 | W12730 | 27x30 | 39,4 | 45,8 | 362 | 0,376 | 50 | 19,7 |
| 52593 | W13032 | 30x32 | 43,0 | 46,0 | 368 | 0,483 | 30 | 15,3 |

Open end wrenches set. Series ARC

Open end wrenches set on a plastic holder. Series ARC

6 pcs



8 pcs



| Code | Item No. | kg | pcs | kg |
|---|----------|------|-----|------|
| 52617 | W1S6PR | 0,55 | 30 | 17,2 |
| Content: 8x10, 10x12, 12x13, 14x15, 13x17, 17x19 mm | | | | |

| Code | Item No. | kg | pcs | kg |
|---|----------|------|-----|------|
| 52618 | W1S8PR | 0,77 | 20 | 16,1 |
| Content: 6x7, 8x9, 8x10, 12x13, 14x15, 16x17, 17x19, 19x22 mm | | | | |

Open end wrenches set in a bag. Series ARC

10 pcs



| Code | Item No. | kg | pcs | kg |
|---|----------|-------|-----|------|
| 52614 | W1S10TB | 1,144 | 16 | 18,9 |
| Content: 6x7, 8x9, 8x10, 10x12, 12x13, 13x14, 14x17, 17x19, 19x22, 22x24 mm | | | | |

11 pcs



12 pcs



| Code | Item No. | kg | pcs | kg |
|--|----------|-------|-----|------|
| 52615 | W1S11TB | 2,313 | 8 | 19,1 |
| Content: 8x10, 10x12, 12x13, 14x15, 13x17, 17x19, 19x22, 22x24, 24x27, 27x30, 30x32 mm | | | | |

| Code | Item No. | kg | pcs | kg |
|--|----------|-------|-----|------|
| 52616 | W1S12TB | 2,375 | 8 | 19,6 |
| Content: 6x7, 8x9, 10x11, 12x13, 14x15, 16x17, 18x19, 20x22, 21x23, 24x27, 25x28, 30x32 mm | | | | |

DOUBLE RING END WRENCHES AND SETS OF THEM

Are applied to work with high-loaded joints, Curved 75° working part facilitates access to hard-to-reach places. The wrenches are made of alloyed chrome-vanadium steel according to DIN 838.

Double ring end wrenches

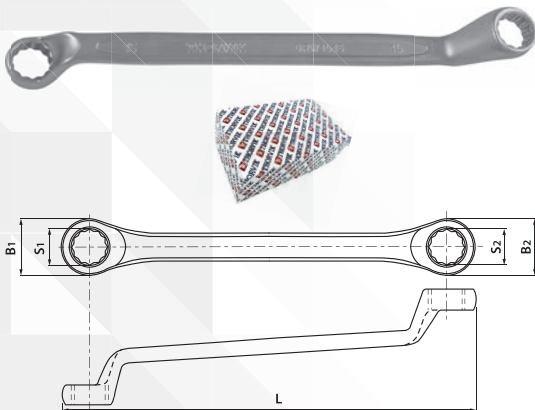

12

Cr-V

DIN



| Code | Item No. | S1xS2, mm | B1, mm | B2, mm | L, mm | kg | pcs | kg |
|-------|----------|-----------|--------|--------|-------|------|---------|---------|
| 52010 | ORW0607 | 6x7 | 10 | 11 | 173 | 0,06 | 100/400 | 5,50/23 |
| 52011 | ORW0809 | 8x9 | 13 | 14 | 185 | 0,07 | 100/200 | 7,50/16 |
| 52012 | ORW1011 | 10x11 | 16 | 17 | 197 | 0,09 | 50/200 | 4,75/20 |
| 52013 | ORW1213 | 12x13 | 18 | 20 | 213 | 0,11 | 50/200 | 5,60/24 |
| 52014 | ORW1415 | 14x15 | 22 | 23 | 226 | 0,14 | 25/150 | 4,10/26 |
| 52015 | ORW1719 | 17x19 | 26 | 28 | 266 | 0,24 | 25/100 | 6,00/25 |
| 52016 | ORW2122 | 21x22 | 31 | 33 | 288 | 0,30 | 10/60 | 3,00/19 |
| 52017 | ORW2427 | 24x27 | 36 | 40 | 326 | 0,44 | 10/40 | 4,40/19 |

Double ring end wrenches set

Double ring end wrenches set on a plastic holder

6 pcs



| Code | Item No. | kg | pcs | kg |
|--|----------|------|------|---------|
| 52018 | ORWS006 | 0,80 | 4/24 | 3,18/23 |
| Content: 6x7, 8x9, 10x11, 12x13, 14x15, 17x19 mm | | | | |

Double ring end wrenches set in a bag

8 pcs



| Code | Item No. | kg | pcs | kg |
|--|----------|------|------|---------|
| 52019 | ORWS008 | 1,50 | 1/12 | 1,50/21 |
| Content: 6x7, 8x9, 10x11, 12x13, 14x15, 17x19, 21x22, 24x27 mm | | | | |

Double ring end wrenches. Series ARC



12 Cr-V DIN

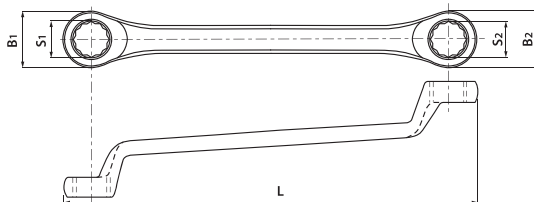

| Code | Item No. | S1xS2, mm | B1, mm | B2, mm | L, mm | kg | pcs | kg |
|-------|----------|-----------|--------|--------|-------|-------|-----|------|
| 52546 | W20607 | 6X7 | 14,4 | 16,2 | 123,4 | 0,047 | 300 | 15,2 |
| 52547 | W20809 | 8X9 | 18,2 | 20,3 | 139,6 | 0,065 | 300 | 20,5 |
| 52548 | W20810 | 8X10 | 18,5 | 22,7 | 139,6 | 0,065 | 300 | 20,5 |
| 52549 | W21011 | 10X11 | 22,9 | 26,6 | 156,7 | 0,096 | 200 | 20,3 |
| 52550 | W21012 | 10X12 | 22,8 | 26,7 | 157,3 | 0,096 | 200 | 20,3 |
| 52551 | W21013 | 10X13 | 22,8 | 27,8 | 156,8 | 0,108 | 200 | 22,6 |
| 52552 | W21213 | 12X13 | 27,7 | 29,5 | 171,8 | 0,108 | 200 | 22,6 |
| 52553 | W21314 | 13X14 | 30,6 | 33,6 | 187,8 | 0,148 | 150 | 23,2 |
| 52554 | W21317 | 13X17 | 30,1 | 35,8 | 204,0 | 0,168 | 100 | 18,1 |
| 52555 | W21415 | 14X15 | 29,2 | 31,7 | 188,2 | 0,148 | 150 | 23,2 |
| 52556 | W21416 | 14X16 | 28,8 | 35,1 | 204,7 | 0,148 | 150 | 23,2 |
| 52557 | W21417 | 14X17 | 29,9 | 35,5 | 204,4 | 0,168 | 100 | 18,1 |
| 52558 | W21617 | 16X17 | 34,3 | 36,3 | 203,9 | 0,168 | 100 | 18,1 |
| 52559 | W21719 | 17X19 | 37,6 | 39,4 | 220,8 | 0,236 | 75 | 18,8 |
| 52560 | W21819 | 18X19 | 37,4 | 39,0 | 220,7 | 0,236 | 75 | 18,8 |
| 52562 | W21922 | 19X22 | 40,6 | 44,5 | 235,5 | 0,305 | 75 | 23,9 |
| 52563 | W22022 | 20X22 | 40,6 | 44,5 | 235,5 | 0,305 | 75 | 23,9 |
| 52564 | W22123 | 21X23 | 42,4 | 46,9 | 244,8 | 0,34 | 50 | 18 |
| 52565 | W22224 | 22X24 | 44,4 | 48,4 | 245,3 | 0,34 | 50 | 18 |
| 52566 | W22427 | 24X27 | 48,9 | 52,9 | 263,9 | 0,408 | 40 | 17,5 |
| 52567 | W22528 | 25X28 | 51,9 | 56,8 | 274,2 | 0,46 | 40 | 19,4 |
| 52568 | W22730 | 27X30 | 51,9 | 56,8 | 274,2 | 0,46 | 40 | 19,4 |
| 52569 | W23032 | 30X32 | 60,1 | 63,4 | 299,1 | 0,583 | 30 | 18,6 |

Double ring end wrenches set. Series ARC

Double ring end wrenches set on a plastic holder. Series ARC



| Code | Item No. | kg | pcs | kg |
|-------|----------|-------|-----|----|
| 52621 | W2S6PR | 0,865 | 20 | 18 |

Content: 8x9, 10x11, 12x13, 14x15, 16x17, 18x19 mm



| Code | Item No. | kg | pcs | kg |
|-------|----------|-------|-----|------|
| 52622 | W2S8PR | 1,240 | 10 | 13,1 |

Content: 6x7, 8x9, 10x11, 12x13, 14x15, 16x17, 18x19, 20x22 mm

Double ring end wrenches set in a bag. Series ARC



| Code | Item No. | kg | pcs | kg |
|-------|----------|-------|-----|------|
| 52623 | W2S8TB | 1,250 | 10 | 14,2 |

Content: 6x7, 8x10, 10x12, 12x13, 13x14, 14x17, 17x19, 19x22 mm

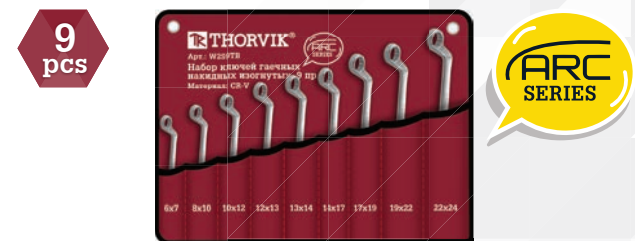

| Code | Item No. | kg | pcs | kg |
|-------|----------|-------|-----|------|
| 52624 | W2S9TB | 1,600 | 10 | 17,8 |

Content: 6x7, 8x10, 10x12, 12x13, 13x14, 14x17, 17x19, 19x22, 22x24 mm

10 pcs

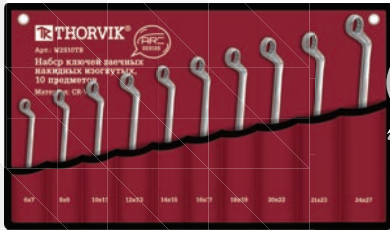

| Code | Item No. | kg | pcs | kg |
|--|----------|-------|-----|----|
| 52619 | W2S10TB | 2,025 | 8 | 18 |
| Content: 6x7, 8x9, 10x11, 12x13, 14x15, 16x17, 18x19, 20x22, 21x23, 24x27 mm | | | | |

12 pcs



| Code | Item No. | kg | pcs | kg |
|--|----------|-------|-----|------|
| 52620 | W2S12TB | 3,217 | 6 | 20,8 |
| Content: 6x7, 8x9, 10x11, 12x13, 14x15, 16x17, 18x19, 20x22, 21x23, 24x27, 25x28, 30x32 mm | | | | |

DOUBLE END FLARE NUT WRENCHES AND SETS OF THEM

Combine in their design the ability to transmit high loads, like a ring end wrench, with the convenience of open end wrench. Flare nut wrenches are used primarily for maintenance of pipe fittings, when the use of an open-end wrench can damage a joint, and it is not possible to apply a ring end wrench or flank socket. The tools are made of vanadium steel according to DIN 3118.

Double end flare nut wrenches

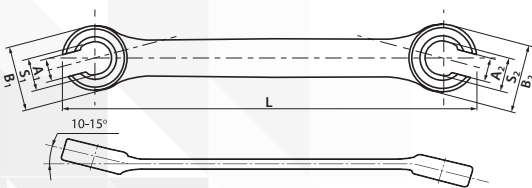

| Code | Item No. | S1xS2, mm | B1xB2, mm | A1xA2, mm | L, mm | kg | pcs | kg |
|-------|----------|-----------|-----------|-----------|-------|------|---------|---------|
| 52050 | FNW0810 | 8x10 | 16x18 | 6x7 | 142 | 0,05 | 100/400 | 4,50/19 |
| 52051 | FNW1012 | 10x12 | 18x20 | 7x9 | 145 | 0,07 | 50/200 | 2,50/11 |
| 52052 | FNW1113 | 11x13 | 20x24 | 8x10 | 164 | 0,08 | 50/200 | 3,75/16 |
| 52053 | FNW1214 | 12x14 | 21x25 | 9x11 | 175 | 0,11 | 50/200 | 4,50/19 |
| 52054 | FNW1719 | 17x19 | 29x32 | 14x15 | 202 | 0,18 | 25/100 | 4,75/20 |

Double end flare nut wrenches set

Double end flare nut wrenches set in a bag

5 pcs



| Code | Item No. | kg | pcs | kg |
|--|----------|------|------|---------|
| 52055 | FNWS005 | 0,47 | 1/30 | 0,47/17 |
| Content: 8x10, 10x12, 11x13, 12x14, 17x19 mm | | | | |

Double end flare nut wrenches. Series ARC

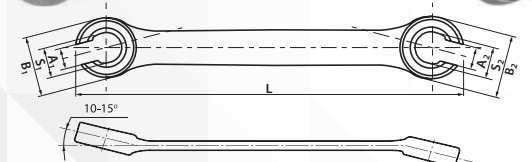

| Code | Item No. | S1xS2, mm | B1xB2, mm | A1xA2, mm | L, mm | kg | pcs | kg |
|-------|----------|-----------|-----------|-----------|--------|--------|-----|------|
| 52594 | W40608 | 6x8 | 12,6x14,3 | 3,37x6,27 | 119,16 | 0,025 | 600 | 16,1 |
| 52595 | W40810 | 8x10 | 14,0x17,4 | 6,70x7,85 | 139,5 | 0,045 | 400 | 19,7 |
| 52596 | W40911 | 9x11 | 17,3x22,1 | 7,20x7,68 | 160,19 | 0,05 | 400 | 21,7 |
| 52597 | W41012 | 10x12 | 17,5x21,8 | 7,84x9,41 | 159,02 | 0,055 | 400 | 23,7 |
| 52598 | W41314 | 13x14 | 23,5x25,8 | 10,2x10,9 | 169,39 | 0,0752 | 250 | 20 |
| 52599 | W41517 | 15x17 | 27,2x28,9 | 11,6x13,3 | 186,67 | 0,106 | 200 | 22,3 |
| 52600 | W41618 | 16x18 | 28,2x30,5 | 12,6x13,8 | 206,82 | 0,13 | 150 | 20,4 |
| 52601 | W41921 | 19x21 | 32,4x38,0 | 14,3x16,0 | 225,99 | 0,205 | 100 | 21,6 |

Double end flare nut wrenches set. Series ARC

Double end flare nut wrenches set in a bag. Series ARC

4 pcs



7 pcs



| Code | Item No. | kg | pcs | kg |
|--------------------------------------|----------|-------|-----|------|
| 52625 | W4S4TB | 0,292 | 50 | 16,6 |
| Content: 8x10, 9x11, 12x13, 15x17 mm | | | | |

| Code | Item No. | kg | pcs | kg |
|---|----------|-------|-----|------|
| 52626 | W4S7TB | 0,570 | 30 | 18,8 |
| Content: 8x10, 9x11, 10x11, 12x13, 13x14, 15x17, 17x19 mm | | | | |

ADJUSTABLE WRENCHES

The range of adjustable Thorvik wrenches includes seven standard sizes providing service of joint elements in the big range. Tools are manufactured of alloyed high-quality chrome-vanadium steel according to the DIN 3117 standard. Thorvik adjustable wrenches are supplied with exact details of mechanism of jaws that provides the minimum working gaps and smooth adjustment. Products have a protective phosphate coating with a metric dimensional scale.

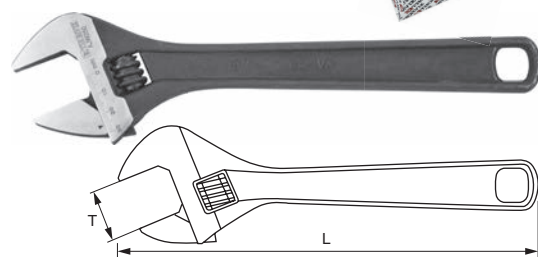

| Code | Item No. | L, mm | T, mm | kg | pcs | kg |
|-------|----------|-------|-------|-------|--------|---------|
| 52251 | AJW100 | 100 | 13 | 0,06 | 10/200 | 0,80/15 |
| 52252 | AJW150 | 150 | 22 | 0,132 | 6/96 | 0,94/15 |
| 52253 | AJW200 | 200 | 27 | 0,24 | 6/60 | 1,60/16 |
| 52254 | AJW250 | 250 | 30 | 0,42 | 6/48 | 2,75/22 |
| 52255 | AJW300 | 300 | 34 | 0,662 | 6/36 | 4,33/26 |
| 52256 | AJW375 | 375 | 46 | 1,39 | 6/18 | 9,00/27 |
| 52257 | AJW450 | 450 | 52 | 1,632 | 2/12 | 3,67/22 |

Technological stages for the production of THORVIK® wrenches:

- STAGE №1 - Cutting of primary preform
- STAGE №2 - Forging and pressing processing (hot stamp)
- STAGE №3 - Felling
- STAGE №4 - Primary formation of working surfaces
- STAGE №5 - Formation of working surfaces (broaching) + primary polishing
- STAGE №6 - Marking. Heat treatment
- STAGE №7 - Vibration-abrasive polishing. Grinding
- STAGE №8 - Electroplating

PIPE WRENCHES

Pipe wrenches are universal tools. Thanks to a special design of gripping allow to serve not only round details, but also the profiled threaded fasteners.

F-type with jaws under 90°

Induction hardened to high hardness jaws with an angle of inclination of the teeth, which allows you to achieve the maximum possible grip force.

S-shaped jaws allow servicing of pipes and fasteners of various profiles.

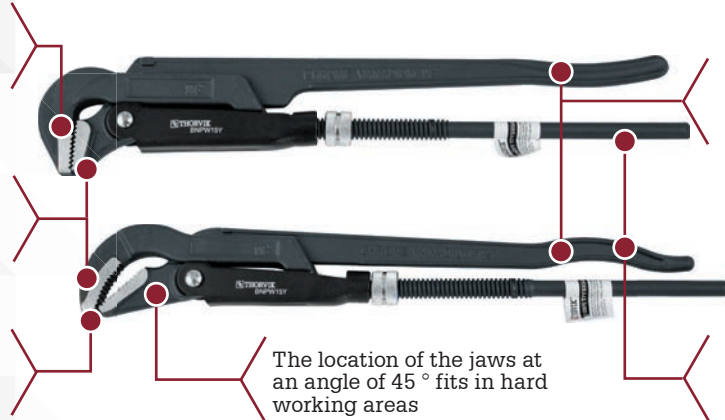



The tools are made of alloy chrome-vanadium steel, according to standards 5234 (Form A, C).

The location of the jaws at an angle of 45° fits in hard working areas

Matte protective coating prevents the appearance of chips on the tool body

Pipe wrenches. F type

 DIN5234 Form A

 Cr-V

TYPE
F **90°**

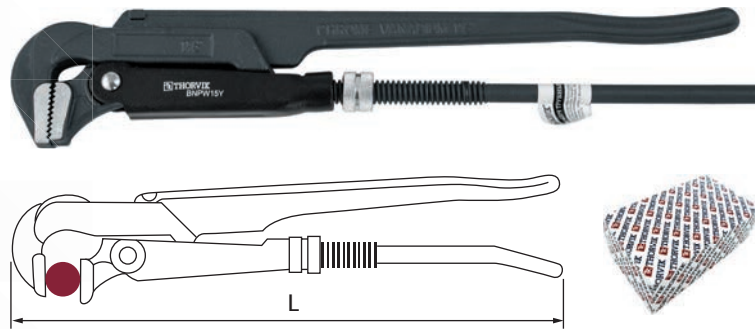

| Code | Item No. | Nº | Range, mm | L, mm | kg | pcs | kg |
|-------|----------|-----|-----------|-------|------|-----|------|
| 52275 | BNPW01L | 1 | 10 - 36 | 300 | 0,83 | 36 | 31,0 |
| 52279 | BNPW15L | 1,5 | 20 - 50 | 400 | 1,35 | 24 | 33,5 |
| 52277 | BNPW02L | 2 | 20 - 63 | 500 | 2,54 | 12 | 31,5 |

Pipe wrenches. S type

 DIN5234 Form C

 Cr-V

TYPE
S **45°**

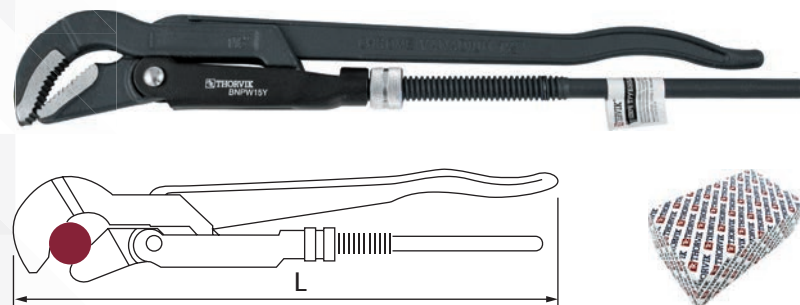

| Code | Item No. | Nº | Range, mm | L, mm | kg | pcs | kg |
|-------|----------|-----|-----------|-------|------|-----|------|
| 52276 | BNPW01Y | 1 | 10 - 36 | 300 | 0,61 | 36 | 23,0 |
| 52280 | BNPW15Y | 1,5 | 20 - 50 | 400 | 1,1 | 24 | 27,5 |
| 52278 | BNPW02Y | 2 | 20 - 63 | 500 | 1,75 | 12 | 22,0 |

Sockets

THORVIK® sockets are manufactured using technologies that allow the transfer of forces exceeding modern standards by 30%. A wide range of sizes, types and profiles, high precision machining, high-quality chrome-vanadium steel and a steady chrome-nickel coating make the tool reliable and durable. The THORVIK® sockets are the basis for creating fitting-assembling tools. Products are made on modern equipment according to DIN 3124.

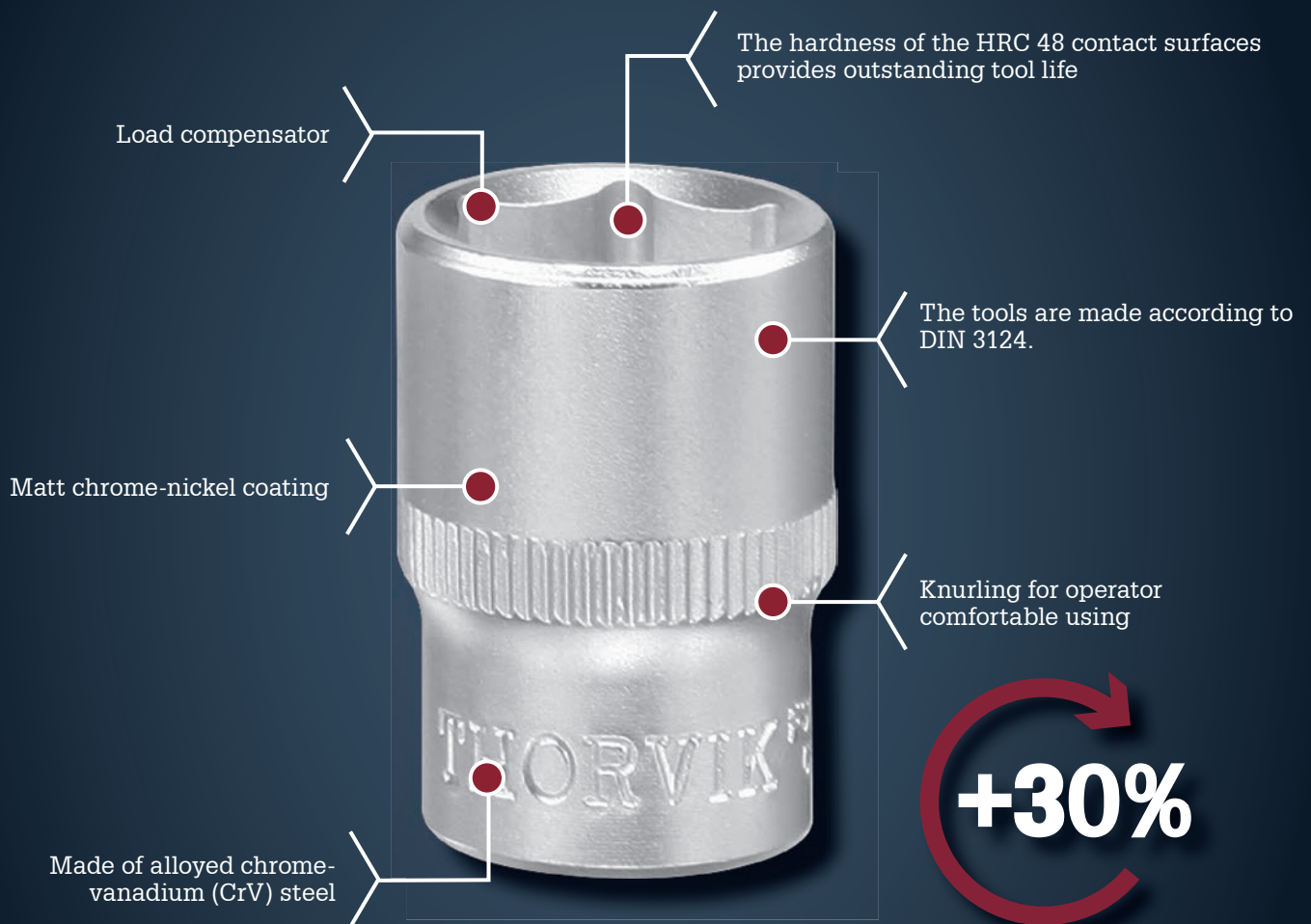

+30%

| | | |
|------------------------------------|------------------------------------|--------------------------------------|
| Cr-V Chrome-vanadium steel | 1/2" Drive size 1/2" (inch) | DIN According to DIN standart |
| 1/4" Drive size 1/4" (inch) | 6 6 point sockets | 1" Drive size 1" (inch) |
| 4 4-point sockets | MP MP (MultiProf) sockets | 12 12-point sockets |

Weight of one item

Quantity in the package / shipping box

Packing weight (gross) / shipping box (gross)

FLANK SOCKETS 1/4"DR

Flank sockets 1/4"DR

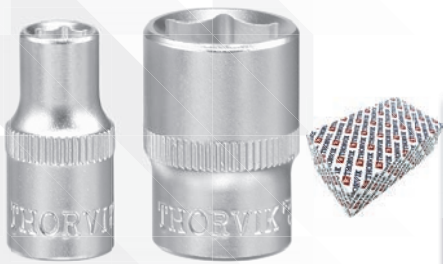

Cr-V 1/4" 6 DIN

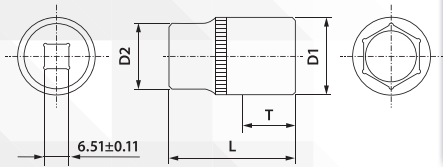

| Code | Item No. | Size, mm | D2, mm | D1, mm | T, mm | L, mm | MF kgf/m | kg | pcs | kg |
|-------|----------|----------|--------|--------|-------|-------|----------|-------|------------|--------------|
| 52064 | FS01405 | 5 | 11,8 | 8,1 | 9,0 | 25 | 1,5 | 0,010 | 100 / 200 | 1,075 / 2,2 |
| 52065 | FS01406 | 6 | 11,8 | 9,3 | 10,1 | 25 | 2,0 | 0,010 | 100 / 500 | 1,090 / 5,7 |
| 52066 | FS01407 | 7 | 11,8 | 10,6 | 11,0 | 25 | 2,7 | 0,010 | 100 / 1000 | 1,185 / 12,2 |
| 52067 | FS01408 | 8 | 11,4 | 11,9 | 11,1 | 25 | 3,4 | 0,010 | 100 / 1000 | 1,135 / 11,7 |
| 52068 | FS01409 | 9 | 11,9 | 12,9 | 11,2 | 25 | 4,1 | 0,015 | 100 / 300 | 1,305 / 4,1 |
| 52069 | FS01410 | 10 | 12,1 | 13,9 | 13,0 | 25 | 4,9 | 0,015 | 100 / 1000 | 1,285 / 13,2 |
| 52070 | FS01411 | 11 | 14,1 | 15,9 | 13,1 | 25 | 5,8 | 0,020 | 100 / 200 | 1,870 / 3,9 |
| 52071 | FS01412 | 12 | 15,1 | 16,9 | 13,0 | 25 | 6,7 | 0,020 | 100 / 1000 | 2,170 / 22,1 |
| 52072 | FS01413 | 13 | 16,1 | 17,9 | 13,0 | 25 | 6,9 | 0,022 | 100 / 1000 | 2,375 / 24,2 |

Deep flank sockets 1/4"DR

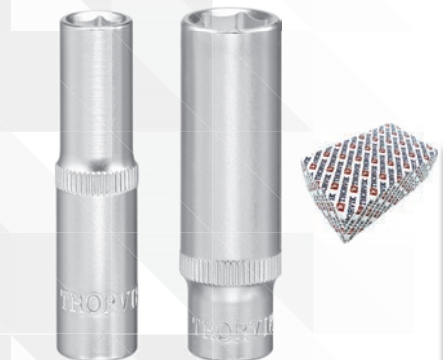

Cr-V 1/4" 6 DIN

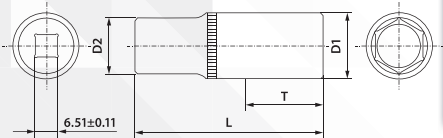

| Code | Item No. | Size, mm | D2, mm | D1, mm | T, mm | L, mm | MF kgf/m | kg | pcs | kg |
|-------|----------|----------|--------|--------|-------|-------|----------|-------|------------|--------------|
| 52073 | FS11405 | 5 | 11,8 | 8,1 | 11,5 | 50 | 1,5 | 0,020 | 100 / 200 | 2,155 / 4,5 |
| 52074 | FS11406 | 6 | 11,8 | 9,3 | 11,8 | 50 | 2,0 | 0,025 | 100 / 200 | 2,325 / 4,9 |
| 52075 | FS11407 | 7 | 11,8 | 10,6 | 11,8 | 50 | 2,7 | 0,025 | 100 / 800 | 2,470 / 20,1 |
| 52076 | FS11408 | 8 | 11,4 | 11,9 | 11,4 | 50 | 3,4 | 0,020 | 100 / 1000 | 2,380 / 24,3 |
| 52077 | FS11409 | 9 | 11,9 | 12,9 | 11,8 | 50 | 4,1 | 0,020 | 100 / 200 | 2,935 / 6,1 |
| 52078 | FS11410 | 10 | 12,1 | 13,9 | 12,5 | 50 | 4,9 | 0,035 | 100 / 600 | 3,635 / 22,2 |
| 52079 | FS11411 | 11 | 14,1 | 15,9 | 14,1 | 50 | 5,8 | 0,040 | 100 / 200 | 4,225 / 8,8 |
| 52080 | FS11412 | 12 | 15,1 | 16,9 | 11,5 | 50 | 6,7 | 0,054 | 100 / 300 | 4,710 / 14,5 |
| 52081 | FS11413 | 13 | 16,1 | 17,9 | 16,1 | 50 | 6,9 | 0,050 | 100 / 400 | 5,160 / 21,0 |

12-point flank sockets 1/4"DR



Cr-V 1/4" 12 DIN

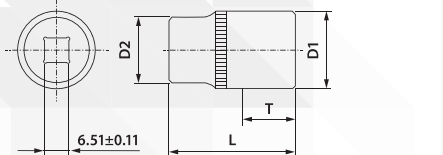

| Code | Item No. | Size, mm | D2, mm | D1, mm | T, mm | L, mm | kg | pcs | kg |
|-------|----------|----------|--------|--------|-------|-------|------|-----|-------|
| 52963 | FS21404 | 4 | 11,79 | 6,85 | 8,05 | 24,85 | 0,01 | 300 | 3,88 |
| 52964 | FS21445 | 4.5 | 11,96 | 7,33 | 9,86 | 24,81 | 0,01 | 300 | 3,35 |
| 52965 | FS21405 | 5 | 11,93 | 8,09 | 7,96 | 24,76 | 0,01 | 300 | 3,46 |
| 52966 | FS21455 | 5.5 | 11,85 | 8,68 | 13,51 | 24,73 | 0,01 | 300 | 3,44 |
| 52967 | FS21406 | 6 | 11,9 | 9,3 | 8,47 | 24,83 | 0,01 | 300 | 3,62 |
| 52968 | FS21407 | 7 | 11,95 | 10,71 | 13,18 | 24,82 | 0,01 | 300 | 3,64 |
| 52969 | FS21408 | 8 | 11,27 | 11,84 | 10,29 | 24,94 | 0,01 | 300 | 3,42 |
| 52970 | FS21409 | 9 | 12,07 | 13,45 | 10,09 | 24,95 | 0,01 | 300 | 3,99 |
| 52971 | FS21410 | 10 | 12,03 | 13,89 | 13,06 | 24,88 | 0,01 | 300 | 3,91 |
| 52972 | FS21411 | 11 | 15,01 | 16,7 | 12,28 | 24,97 | 0,02 | 300 | 6,55 |
| 52973 | FS21412 | 12 | 16 | 17,8 | 13,47 | 24,87 | 0,02 | 363 | 8,01 |
| 52974 | FS21413 | 13 | 16,01 | 17,77 | 12,76 | 24,5 | 0,02 | 390 | 9,58 |
| 52975 | FS21414 | 14 | 17,94 | 19,78 | 13,76 | 24,64 | 0,03 | 300 | 10,06 |

12-point deep flank sockets 1/4"DR

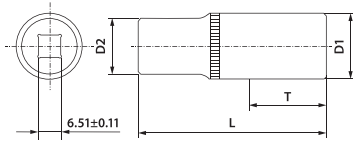

Cr-V 1/4" 12 DIN

| Code | Item No. | Size, mm | D2, mm | D1, mm | T, mm | L, mm | kg | pcs | kg |
|-------|----------|----------|--------|--------|-------|-------|------|-----|-------|
| 52976 | FS31406 | 6 | 11,78 | 10,35 | 14,99 | 50,32 | 0,02 | 200 | 5,16 |
| 52977 | FS31407 | 7 | 11,85 | 10,72 | 22,07 | 49,88 | 0,02 | 200 | 5,07 |
| 52978 | FS31408 | 8 | 11,31 | 11,91 | 20,32 | 49,99 | 0,02 | 200 | 5,01 |
| 52979 | FS31409 | 9 | 11,99 | 13,45 | 17,47 | 49,93 | 0,03 | 200 | 6,5 |
| 52980 | FS31410 | 10 | 12,51 | 14,68 | 20,88 | 49,97 | 0,04 | 200 | 8,5 |
| 52981 | FS31411 | 11 | 21,73 | 16,39 | 13,3 | 37,93 | 0,04 | 300 | 12,98 |
| 52982 | FS31412 | 12 | 12,81 | 17,82 | 13,9 | 37,99 | 0,05 | 300 | 15,6 |
| 52983 | FS31413 | 13 | 21,92 | 18,82 | 14,97 | 38,16 | 0,05 | 300 | 15,32 |

MultiProf flank sockets 1/4"DR

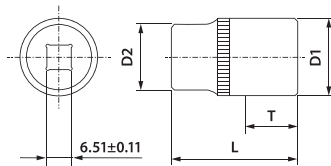

Cr-V 1/4" MP3 DIN

| Code | Item No. | Size, mm | D2, mm | D1, mm | T, mm | L, mm | kg | pcs | kg |
|-------|----------|----------|--------|--------|-------|-------|------|-----|------|
| 52920 | MP01404 | 4 | 11,88 | 6,89 | 9,83 | 24,91 | 0,01 | 300 | 3,24 |
| 52921 | MP01445 | 4.5 | 11,85 | 7,38 | 8,01 | 24,89 | 0,01 | 300 | 3,23 |
| 52922 | MP01405 | 5 | 11,9 | 8,13 | 8,52 | 24,91 | 0,01 | 300 | 3,28 |
| 52923 | MP01455 | 5.5 | 11,91 | 8,88 | 11,23 | 25,03 | 0,01 | 300 | 3,4 |
| 52924 | MP01406 | 6 | 11,81 | 9,54 | 9,15 | 24,9 | 0,01 | 300 | 3,6 |
| 52925 | MP01407 | 7 | 11,56 | 10,74 | 10,67 | 24,95 | 0,01 | 300 | 4,34 |
| 52926 | MP01408 | 8 | 11,88 | 12,92 | 10,3 | 24,98 | 0,01 | 300 | 4,19 |
| 52927 | MP01409 | 9 | 12,07 | 13,41 | 10,09 | 24,95 | 0,01 | 300 | 4,5 |
| 52928 | MP01410 | 10 | 13,96 | 13,98 | 10,11 | 24,96 | 0,02 | 300 | 6,01 |
| 52929 | MP01411 | 11 | 15 | 16,69 | 12,28 | 24,97 | 0,02 | 363 | 8,25 |
| 52930 | MP01412 | 12 | 15,99 | 17,2 | 13,47 | 24,89 | 0,02 | 390 | 9,55 |
| 52931 | MP01413 | 13 | 17,95 | 18,49 | 12,9 | 24,77 | 0,03 | 300 | 9,97 |
| 52932 | MP01414 | 14 | 18,03 | 19,75 | 12,71 | 24,99 | 0,03 | 300 | 9,64 |

MultiProf deep flank sockets 1/4"DR

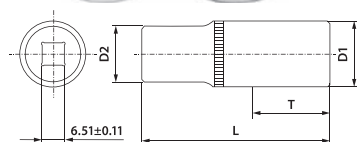
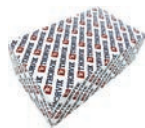

Cr-V 1/4" MP3 DIN

| Code | Item No. | Size, mm | D2, mm | D1, mm | T, mm | L, mm | kg | pcs | kg |
|-------|----------|----------|--------|--------|-------|-------|------|-----|-------|
| 52933 | MP11406 | 6 | 11,9 | 9,25 | 17,28 | 50,19 | 0,02 | 200 | 4,86 |
| 52934 | MP11407 | 7 | 11,85 | 10,72 | 22,07 | 49,88 | 0,02 | 200 | 5,04 |
| 52935 | MP11408 | 8 | 11,96 | 12,13 | 17,46 | 49,87 | 0,03 | 200 | 7,13 |
| 52936 | MP11409 | 9 | 11,99 | 13,41 | 11,99 | 49,94 | 0,03 | 200 | 6,69 |
| 52937 | MP11410 | 10 | 14 | 14,7 | 18,5 | 50,07 | 0,04 | 300 | 13,2 |
| 52938 | MP11411 | 11 | 15,04 | 15,93 | 20,48 | 49,97 | 0,05 | 300 | 15,5 |
| 52939 | MP11412 | 12 | 15,93 | 17,24 | 19,45 | 49,96 | 0,05 | 300 | 15,91 |
| 52940 | MP11413 | 13 | 15,94 | 18,5 | 19,48 | 49,87 | 0,06 | 300 | 18,25 |

FLANK SOCKETS 1/2"DR

Flank sockets 1/2"DR

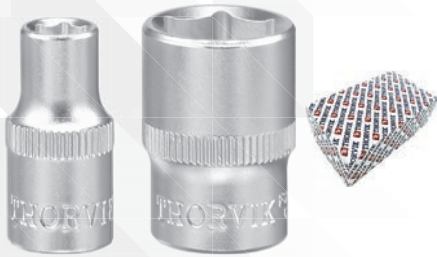

Cr-V 1/2" 6 DIN

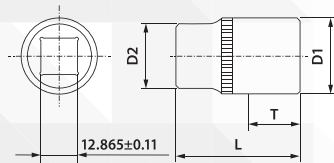

| Code | Item No. | Size, mm | D2, mm | D1, mm | T, mm | L, mm | MF kgf/m | kg | pcs | kg |
|-------|----------|----------|--------|--------|-------|-------|----------|-------|---------|--------------|
| 52089 | FS01208 | 8 | 21,8 | 13,1 | 13,8 | 38 | 14,8 | 0,050 | 100/400 | 4,920 / 20,1 |
| 52090 | FS01209 | 9 | 21,8 | 14,3 | 13,8 | 38 | 17,8 | 0,050 | 100/400 | 5,045 / 20,6 |
| 52091 | FS01210 | 10 | 21,8 | 15,3 | 13,8 | 38 | 21,3 | 0,050 | 100/400 | 5,040 / 20,5 |
| 52092 | FS01211 | 11 | 21,8 | 16,3 | 14,0 | 38 | 25,0 | 0,050 | 100/400 | 5,115 / 20,9 |
| 52093 | FS01212 | 12 | 21,8 | 17,8 | 14,3 | 38 | 28,8 | 0,050 | 100/400 | 5,215 / 21,3 |
| 52094 | FS01213 | 13 | 21,8 | 19,1 | 14,3 | 38 | 33,2 | 0,055 | 100/400 | 5,360 / 21,9 |
| 52095 | FS01214 | 14 | 21,8 | 20,3 | 14,2 | 38 | 37,8 | 0,055 | 100/400 | 5,505 / 22,5 |
| 52096 | FS01215 | 15 | 20,9 | 21,6 | 14,1 | 38 | 42,5 | 0,055 | 100/400 | 5,395 / 22,0 |
| 52097 | FS01216 | 16 | 20,8 | 21,8 | 13,8 | 38 | 47,8 | 0,050 | 100/400 | 5,085 / 20,8 |
| 52098 | FS01217 | 17 | 21,8 | 23,8 | 14,3 | 38 | 53,1 | 0,065 | 100/300 | 6,420 / 19,7 |
| 52099 | FS01218 | 18 | 23,9 | 25,4 | 14,4 | 38 | 56,9 | 0,075 | 100/300 | 7,870 / 24,1 |
| 52100 | FS01219 | 19 | 23,9 | 25,8 | 14,9 | 38 | 56,9 | 0,065 | 100/300 | 6,590 / 20,3 |
| 52101 | FS01221 | 21 | 25,9 | 27,8 | 15,8 | 38 | 56,9 | 0,085 | 50/300 | 4,325 / 26,5 |
| 52102 | FS01222 | 22 | 26,1 | 29,8 | 15,6 | 38 | 56,9 | 0,095 | 50/200 | 4,860 / 19,6 |
| 52103 | FS01224 | 24 | 27,9 | 31,8 | 15,9 | 38 | 56,9 | 0,110 | 50/200 | 5,495 / 22,4 |
| 52104 | FS01227 | 27 | 30,9 | 35,7 | 19,0 | 42 | 56,9 | 0,155 | 40/160 | 6,400 / 26,0 |
| 52105 | FS01230 | 30 | 34,0 | 39,7 | 22,0 | 44 | 56,9 | 0,200 | 30/120 | 6,145 / 25,0 |
| 52106 | FS01232 | 32 | 36,0 | 41,8 | 21,8 | 44 | 56,9 | 0,225 | 25/100 | 5,750 / 23,4 |

Deep flank sockets 1/2"DR



Cr-V 1/2" 6 DIN

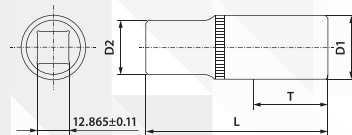

| Code | Item No. | Size, mm | D2, mm | D1, mm | T, mm | L, mm | MF kgf/m | kg | pcs | kg |
|-------|----------|----------|--------|--------|-------|-------|----------|-------|--------|------------|
| 52107 | FS11210 | 10 | 21,9 | 15,3 | 19,4 | 76,9 | 21,3 | 0,095 | 50/200 | 4,83/19,6 |
| 52108 | FS11212 | 12 | 21,9 | 17,8 | 18,3 | 76,9 | 28,8 | 0,100 | 50/200 | 5,145/20,8 |
| 52109 | FS11213 | 13 | 21,9 | 19,1 | 19,3 | 76,9 | 33,2 | 0,105 | 50/200 | 5,495/22,2 |
| 52110 | FS11214 | 14 | 21,9 | 20,3 | 33,0 | 76,9 | 37,8 | 0,110 | 50/200 | 5,725/23,4 |
| 52111 | FS11215 | 15 | 21,9 | 21,6 | 33,0 | 76,9 | 42,5 | 0,110 | 50/200 | 5,67/23 |
| 52112 | FS11216 | 16 | 21,9 | 21,8 | 31,4 | 76,9 | 47,8 | 0,100 | 50/200 | 5,13/20,8 |
| 52113 | FS11217 | 17 | 21,7 | 23,8 | 31,4 | 76,9 | 53,1 | 0,125 | 50/200 | 6,265/25,5 |
| 52114 | FS11218 | 18 | 22,9 | 25,4 | 31,0 | 76,9 | 56,9 | 0,150 | 40/160 | 6,055/24,6 |
| 52115 | FS11219 | 19 | 23,8 | 25,8 | 31,6 | 76,9 | 56,9 | 0,140 | 40/160 | 5,735/23,3 |
| 52116 | FS11221 | 21 | 25,8 | 27,8 | 31,6 | 76,9 | 56,9 | 0,165 | 30/120 | 5,01/20,4 |
| 52117 | FS11222 | 22 | 26,0 | 29,8 | 32,9 | 76,9 | 56,9 | 0,185 | 30/120 | 5,68/23,1 |
| 52118 | FS11224 | 24 | 28,0 | 31,8 | 32,7 | 76,9 | 56,9 | 0,210 | 25/100 | 5,32/21,7 |

THORVIK® «MULTIPROF»

The revolutionary THORVIK® "MultiProf" system of bench-mounting tools is able to save the user from the need to purchase a large number of tools. One THORVIK® "MultiProf" nominal socket size is suitable for eight different profiles and is used for nuts and bolt heads of 6 and 12-point metric sizes, 6 and 12-point inch sizes, external TORX®, SPLINE bolts, and fasteners of three and four-points. The THORVIK® "MultiProf" system is also able to work with damaged (rounded to 30%) fasteners. The contact spot with the fasteners is distributed over a larger area, in contrast to the standard profile, which has point contact spots. The THORVIK® "MultiProf" system of bench-mounting tools has a wide range of applications: it is recommended for use in industrial plants with a high load of intensity, the organization of maintenance of aviation, automotive, agricultural, household appliances, etc.

12-point flank sockets 1/2"DR

Cr-V 1/2" 12 DIN

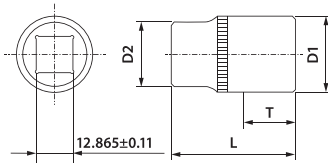

| Code | Item No. | Size, mm | D2, mm | D1, mm | T, mm | L, mm | kg | pcs | kg |
|-------|----------|----------|--------|--------|-------|-------|------|-----|-------|
| 52984 | FS21210 | 10 | 21,86 | 15,31 | 14,38 | 38,11 | 0,05 | 300 | 15,44 |
| 52985 | FS21211 | 11 | 21,72 | 16,57 | 13,9 | 38,02 | 0,05 | 300 | 15,54 |
| 52986 | FS21212 | 12 | 21,73 | 17,84 | 14,28 | 38,09 | 0,05 | 300 | 15,94 |
| 52987 | FS21213 | 13 | 21,73 | 18,79 | 13,75 | 38,07 | 0,05 | 300 | 16,32 |
| 52988 | FS21214 | 14 | 21,85 | 20,26 | 14,07 | 38,17 | 0,05 | 300 | 16,42 |
| 52989 | FS21215 | 15 | 20,77 | 21,91 | 14,87 | 37,9 | 0,05 | 300 | 16,18 |
| 52990 | FS21216 | 16 | 20,77 | 21,82 | 14,1 | 38,06 | 0,05 | 300 | 15,12 |
| 52991 | FS21217 | 17 | 22,04 | 23,78 | 15,03 | 37,85 | 0,06 | 324 | 20,75 |
| 52992 | FS21218 | 18 | 22,89 | 25,77 | 14,75 | 38 | 0,08 | 300 | 24,75 |
| 52993 | FS21219 | 19 | 23,34 | 25,83 | 15,44 | 38,29 | 0,06 | 300 | 19,55 |
| 52994 | FS21220 | 20 | 26,13 | 27,77 | 16,2 | 38,04 | 0,08 | 196 | 16,95 |
| 52995 | FS21221 | 21 | 26,05 | 27,86 | 19,97 | 38,09 | 0,08 | 300 | 24,75 |
| 52996 | FS21222 | 22 | 26,02 | 29,82 | 15,67 | 37,98 | 0,09 | 200 | 18,43 |
| 52997 | FS21224 | 24 | 28,13 | 31,94 | 17,33 | 38,24 | 0,10 | 200 | 21,27 |
| 52998 | FS21227 | 27 | 31,06 | 35,82 | 18,23 | 42,17 | 0,15 | 100 | 15,34 |
| 52999 | FS21230 | 30 | 34,14 | 39,96 | 22 | 43,22 | 0,19 | 100 | 19,76 |
| 53001 | FS21232 | 32 | 36,02 | 41,69 | 22,26 | 44,09 | 0,21 | 100 | 21,67 |

12-point deep flank sockets 1/2"DR

Cr-V 1/2" 12 DIN

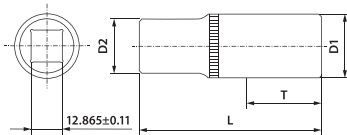

| Code | Item No. | Size, mm | D2, mm | D1, mm | T, mm | L, mm | kg | pcs | kg |
|-------|----------|----------|--------|--------|-------|-------|------|-----|-------|
| 53002 | FS31214 | 14 | 20,95 | 21,7 | 36,13 | 77,34 | 0,11 | 200 | 23,31 |
| 53003 | FS31215 | 15 | 20,93 | 21,81 | 32,13 | 76,95 | 0,11 | 200 | 22,85 |
| 53004 | FS31217 | 17 | 22,16 | 23,79 | 31,83 | 77,3 | 0,12 | 200 | 25,65 |
| 53005 | FS31219 | 19 | 24 | 25,9 | 36,23 | 77,13 | 0,14 | 160 | 23,28 |
| 53006 | FS31222 | 22 | 26,01 | 29,85 | 33,32 | 76,96 | 0,18 | 120 | 22,79 |

MultiProf flank sockets 1/2"DR

Cr-V 1/4" MP DIN

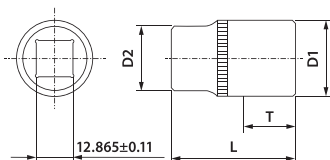

| Code | Item No. | Size, mm | D2, mm | D1, mm | T, mm | L, mm | kg | pcs | kg |
|-------|----------|----------|--------|--------|-------|-------|------|-----|-------|
| 52941 | MP01210 | 10 | 21,78 | 15,47 | 14,17 | 38,24 | 0,05 | 300 | 15,37 |
| 52942 | MP01211 | 11 | 21,85 | 16,54 | 14,42 | 38,03 | 0,05 | 300 | 15,54 |
| 52943 | MP01212 | 12 | 21,87 | 17,95 | 14,96 | 38,05 | 0,05 | 300 | 15,41 |
| 52944 | MP01213 | 13 | 21,89 | 19,12 | 14,27 | 38 | 0,05 | 300 | 15,79 |
| 52945 | MP01214 | 14 | 21,87 | 20,31 | 14,17 | 37,92 | 0,05 | 300 | 16,34 |
| 52946 | MP01215 | 15 | 20,66 | 21,79 | 15,79 | 37,91 | 0,05 | 300 | 15,55 |
| 52947 | MP01216 | 16 | 20,99 | 23,83 | 14,24 | 38,07 | 0,06 | 324 | 20,23 |
| 52948 | MP01217 | 17 | 21,97 | 23,74 | 13,67 | 39,97 | 0,06 | 324 | 20 |
| 52949 | MP01218 | 18 | 22,97 | 25,84 | 14,11 | 37,99 | 0,07 | 300 | 22,72 |
| 52950 | MP01219 | 19 | 22,96 | 25,89 | 16,89 | 37,98 | 0,06 | 300 | 18,61 |
| 52951 | MP01220 | 20 | 26,04 | 27,85 | 18,54 | 38,09 | 0,08 | 196 | 16,21 |
| 52952 | MP01221 | 21 | 26,07 | 29,86 | 18,12 | 38,04 | 0,09 | 200 | 18,94 |
| 52953 | MP01222 | 22 | 26,07 | 29,84 | 18,13 | 38,49 | 0,08 | 200 | 17,42 |
| 52954 | MP01224 | 24 | 26,04 | 27,85 | 18,54 | 38,12 | 0,10 | 200 | 20,15 |
| 52955 | MP01227 | 27 | 31,05 | 36,03 | 19,92 | 42,22 | 0,14 | 100 | 14,79 |
| 52956 | MP01230 | 30 | 33,99 | 39,79 | 20,67 | 43,68 | 0,18 | 100 | 18,75 |
| 52957 | MP01232 | 32 | 36,13 | 41,81 | 20,61 | 43,76 | 0,20 | 100 | 20,61 |

MultiProf deep flank sockets 1/2"DR

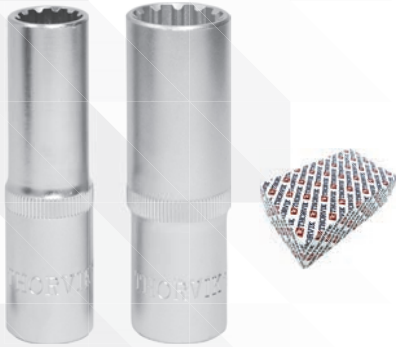

Cr-V 1/4" MP DIN

| Code | Item No. | Size, mm | D2, mm | D1, mm | T, mm | L, mm | kg | pcs | kg |
|-------|----------|----------|--------|--------|-------|-------|------|-----|-------|
| 52958 | MP11214 | 14 | 21,7 | 20,38 | 30,95 | 78,22 | 0,11 | 200 | 22,64 |
| 52959 | MP11215 | 15 | 21,06 | 21,94 | 31,96 | 77,34 | 0,11 | 200 | 22,32 |
| 52960 | MP11217 | 17 | 22,06 | 23,98 | 31,9 | 77,15 | 0,12 | 200 | 24,47 |
| 52961 | MP11219 | 19 | 23,95 | 27,81 | 35,64 | 77,11 | 0,14 | 160 | 23,43 |
| 52962 | MP11222 | 22 | 26,15 | 29,82 | 28,27 | 77,2 | 0,18 | 120 | 22,6 |

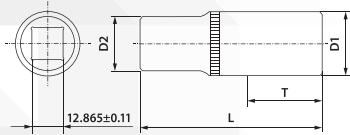

Spark plug sockets

Cr-V 1/2" 6 DIN

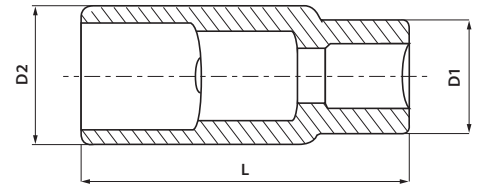
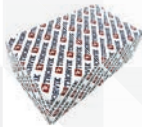

| Code | Item No. | Size, mm | D2, mm | D1, mm | L, mm | kg | pcs | kg |
|-------|----------|----------|--------|--------|-------|-------|----------|--------------|
| 52119 | SPS1216 | 16 | 21.8 | 21.8 | 65 | 0,095 | 60 / 240 | 5,72 / 23,3 |
| 52120 | SPS1221 | 21 | 23.6 | 27.7 | 65 | 0,140 | 40 / 160 | 5,805 / 23,6 |

FLANK SOCKETS 1"DR

4-point flank sockets 1"DR for labor save wrench

Cr-V 1" 4 DIN



| Code | Item No. | Size, mm |
|-------|-----------|----------|
| 52892 | LSWS00117 | 17 |
| 52893 | LSWS00119 | 19 |
| 52772 | LSWS00121 | 21 |
| 52773 | LSWS00122 | 22 |

6-point flank sockets 1"DR for labor save wrench

Cr-V 1" 6 DIN

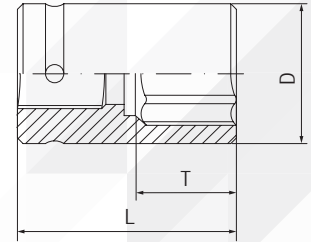

| Code | Item No. | Size, mm | D, mm | T, mm | L, mm | kg | pcs | kg |
|-------|-----------|----------|-------|-------|-------|--------|-----|-------|
| 52755 | LSWS00124 | 24 | 40 | 25 | 78 | 0,5544 | 50 | 27,72 |
| 52756 | LSWS00127 | 27 | 44 | 27 | 78 | 0,592 | 50 | 29,6 |
| 52757 | LSWS00130 | 30 | 47 | 30 | 78 | 0,6104 | 50 | 30,52 |
| 52758 | LSWS00132 | 32 | 48,5 | 30 | 78 | 0,6324 | 50 | 31,62 |
| 52759 | LSWS00133 | 33 | 49 | 30 | 78 | 0,648 | 50 | 32,4 |
| 52760 | LSWS00134 | 34 | 50 | 32 | 78 | 0,6988 | 50 | 34,94 |
| 52761 | LSWS00136 | 36 | 52 | 32 | 78 | 0,7112 | 50 | 35,56 |
| 52762 | LSWS00138 | 38 | 55 | 45 | 78 | 0,8128 | 50 | 40,64 |
| 52763 | LSWS00141 | 41 | 58 | 45 | 78 | 0,8736 | 50 | 43,68 |
| 52764 | LSWS00146 | 46 | 68 | 45 | 80 | 1,1138 | 32 | 35,64 |
| 52765 | LSWS00150 | 50 | 72 | 45 | 80 | 1,175 | 32 | 37,6 |
| 52766 | LSWS00152 | 52 | 75 | 45 | 80 | 1,3781 | 32 | 44,1 |
| 52767 | LSWS00155 | 55 | 78 | 45 | 80 | 1,3238 | 32 | 42,36 |
| 52768 | LSWS00160 | 60 | 84 | 45 | 80 | 1,4344 | 18 | 25,82 |
| 52769 | LSWS00165 | 65 | 89 | 48 | 90 | 1,9356 | 18 | 34,84 |
| 52770 | LSWS00170 | 70 | 94 | 48 | 90 | 2,2889 | 18 | 41,2 |
| 52771 | LSWS00175 | 75 | 104 | 48 | 90 | 2,0533 | 18 | 36,96 |

Flank sockets set for labor save wrench

11 pcs.



Cr-V 1" 21-50 mm

| Code | Item No. |
|--|----------|
| 52774 | LSWS11S |
| <p>Content (11 pieces): 4-point sockets for labor save wrench, 2 pcs: 21, 22 mm; 6-point sockets for labor save wrench, 9 pcs: 27, 30, 32, 33, 36, 38, 41, 46, 50 mm.</p> | |

Handles, Universal Joints, Ratchets

Auxiliary tool that is used to transfer torque to the flank socket. It is part of fitting-assembling tools. The range of THORVIK® drives is represented by products that are diverse in scope, design and technology, and includes various joints, extenders, ratchet handles and adapters. Tools of this group will satisfy the needs of the user, both in ease of use and strength and reliability characteristics of products.

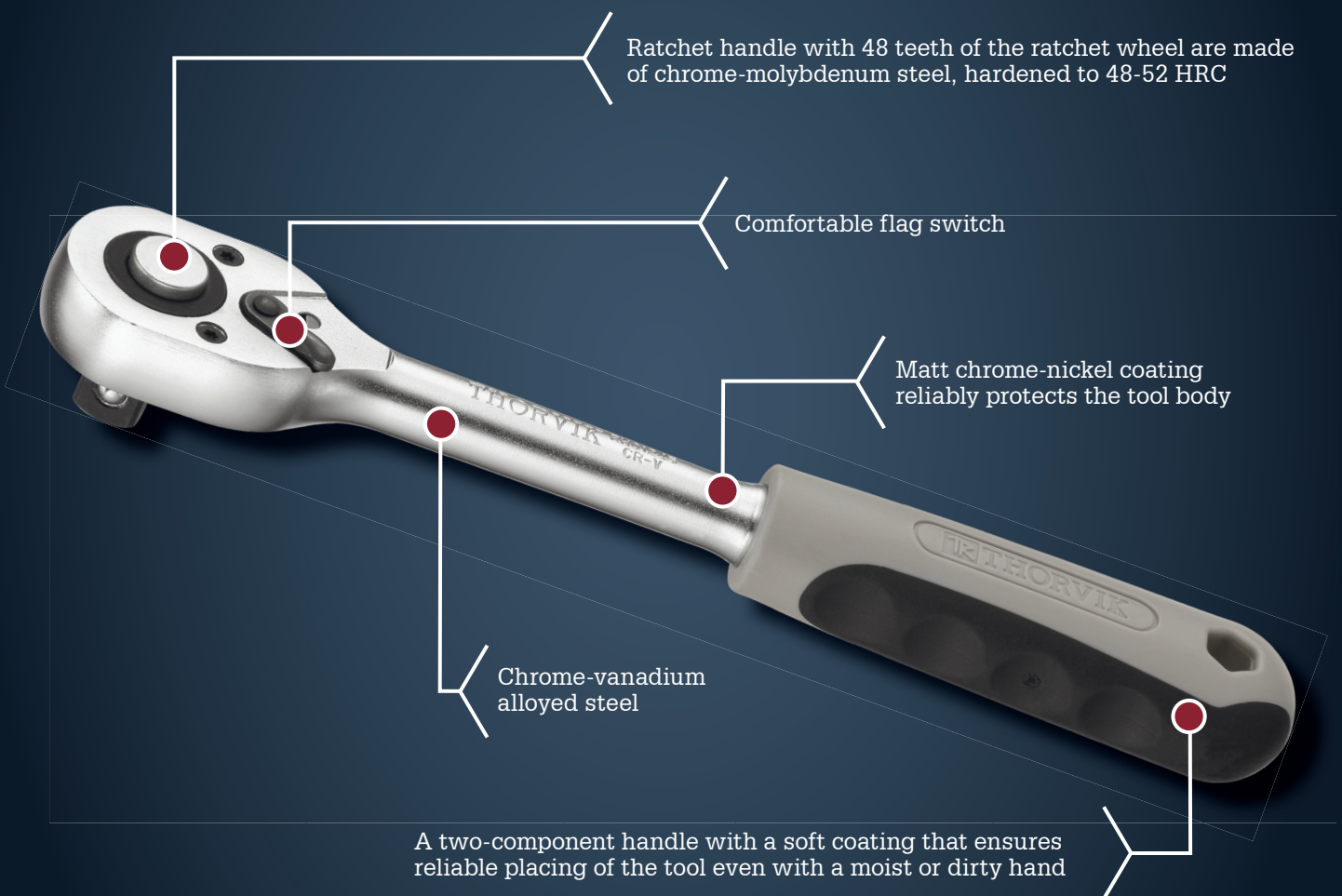

Cr-V Chrome-vanadium steel

1/4" Drive size 1/4" (inch)

1/2" Drive size 1/2" (inch)



Weight of one item



Quantity in the package / shipping box



Packing weight (gross) / shipping box (gross)

HANDLES

Flexible Handle

Cr-V

1/2"



| Code | Item No. | DR | L, mm | kg | pcs | kg |
|-------|----------|-----|-------|------|-------|------------|
| 52125 | FH12380 | 1/2 | 380 | 0,62 | 10/40 | 6,275/25,5 |



Spare parts and repair kits are available for this product:

Repair kit for flexible handle FH12380
Code: 52304; Item No.: FH12380RK

Sliding T bar

Cr-V

1/4" 1/2"



| Code | Item No. | DR | L, mm | kg | pcs | kg |
|-------|----------|-----|-------|------|---------|-----------|
| 52085 | TH14011 | 1/4 | 110 | 0,05 | 100/400 | 4,57/18,7 |
| 52121 | TH12250 | 1/2 | 250 | 0,36 | 10/50 | 3,62/18,5 |

Spinner handle

Cr-V

1/4"

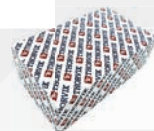

| Code | Item No. | DR | L, mm | kg | pcs | kg |
|-------|----------|-----|-------|------|--------|----------|
| 52088 | SH14150 | 1/4 | 150 | 0,09 | 50/200 | 4,4/18,2 |

RATCHET HANDLES

Ratchet handle

Cr-V

1/4" 1/2"

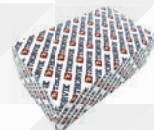

| Code | Item No. | DR | L, mm | Number of teeth | kg | pcs | kg |
|-------|----------|-----|-------|-----------------|------|--------|------------|
| 52082 | RH01445 | 1/4 | 150 | 48 | 0,14 | 10/100 | 1,405/14 |
| 52126 | RH01245 | 1/2 | 250 | 48 | 0,50 | 10/40 | 5,095/21,5 |



Spare parts and repair kits are available for this product:

Repair kit for ratchet handle RH01245RK
Code: 52305; Item No.: RH01245RK

Repair kit for ratchet handle RH01445RK
Code: 52306; Item No.: RH01445RK

EXTENSIONS

Extensions

Cr-V

1/4"

1/2"

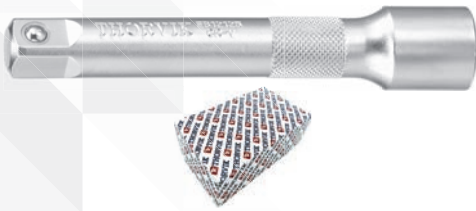

| Code | Item No. | DR | L, mm | kg | pcs | kg |
|-------|----------|-----|-------|------|----------|------------|
| 52083 | EB14050 | 1/4 | 50 | 0,03 | 100/1000 | 2,455/25 |
| 52084 | EB14100 | 1/4 | 100 | 0,05 | 100/600 | 4,42/27 |
| 52122 | EB12125 | 1/2 | 125 | 0,20 | 20/100 | 3,935/20 |
| 52123 | EB12250 | 1/2 | 250 | 0,39 | 10/50 | 3,925/19,9 |

Flexible extension bar

Cr-V

1/4"



| Code | Item No. | DR | L, mm | kg | pcs | kg |
|-------|----------|-----|-------|------|--------|-----------|
| 52087 | FEB1415 | 1/4 | 150 | 0,06 | 50/400 | 3,04/24,8 |

UNIVERSAL JOINTS

Universal joints

Cr-V

1/4"

1/2"



| Code | Item No. | DR | L, mm | kg | pcs | kg |
|-------|----------|-----|-------|------|---------|------------|
| 52086 | UJ14000 | 1/4 | 35 | 0,03 | 100/500 | 2,5/12,8 |
| 52124 | UJ12000 | 1/2 | 70 | 0,16 | 30/120 | 4,725/19,2 |







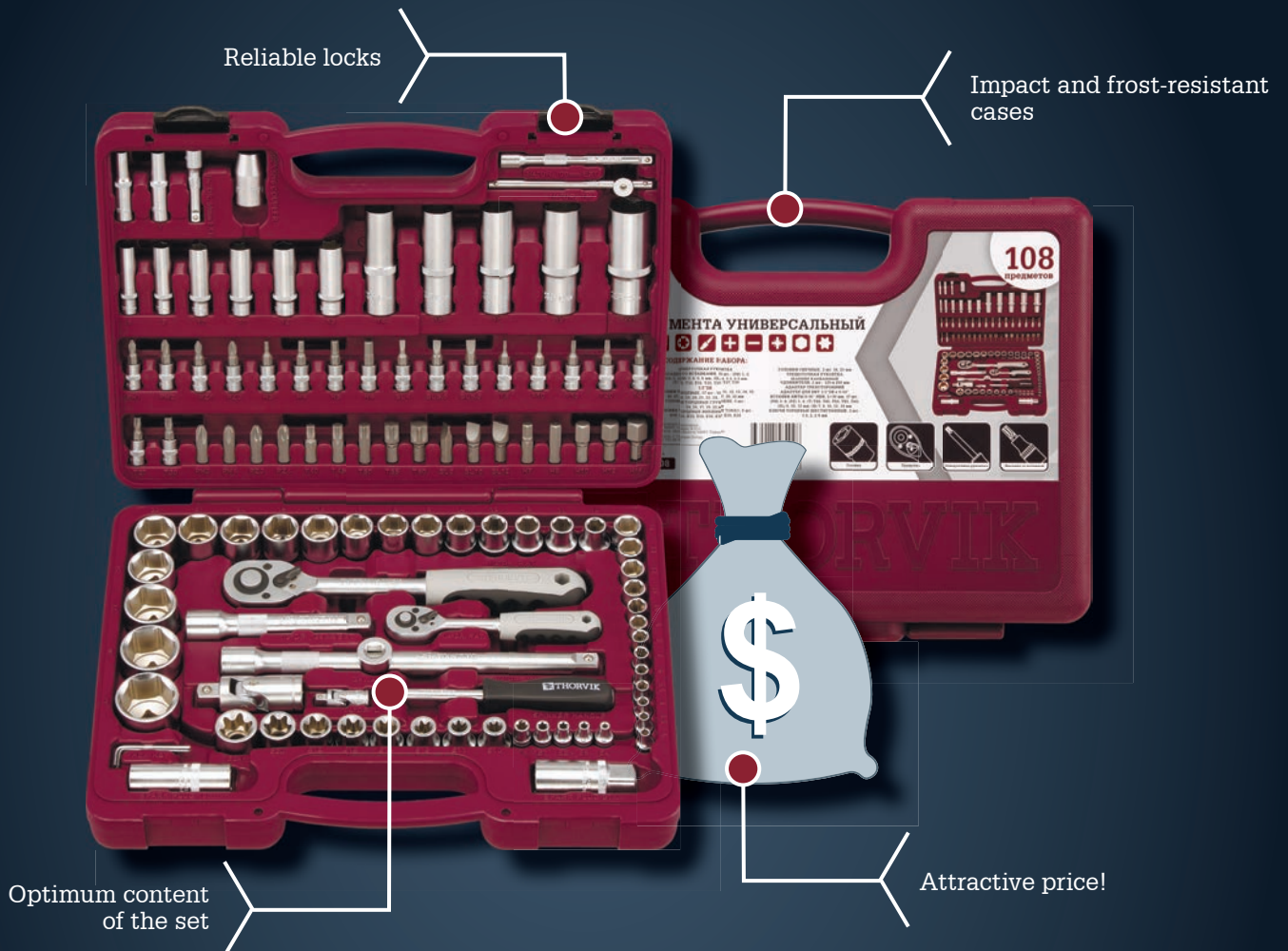









Tool sets

THORVIK® tool sets - high quality of set items, convenient durable storage cases, optimal content to meet the operator's needs for servicing the equipment and to provide with all the necessary workplace during fitting and assembly work.



-  Chrome-vanadium steel
-  Drive size 1/4" (inch)
-  Drive size 3/8" (inch)
-  Drive size 1/2" (inch)
-  Spark plug sockets
-  6-points flank sockets
-  12-point sockets

-  MP (MultiProf) sockets
-  TORX®
-  E-TORX®
-  HEX
-  PHILLIPS®
-  SL Slotted
-  POZIDRIV®

-  Spanners
-  Pliers
-  Adjustable joint pliers
-  Hammer
-  Adjustable wrench
-  Flare nut wrench
-  SPLINE



Weight of one item



Quantity in the package / shipping box



Packing weight (gross) / shipping box (gross)

1/4"DR tool set

38 pcs



| Code | Item No. | kg | pcs | kg |
|-----------------------------|----------|--|-----|-------|
| 52056 | UTS0038 | 1,22 | 10 | 12,20 |
| Content (38 pieces): | | | | |
| Sockets 1/4"DR, 13 pcs | | 4, 4.5, 5, 5.5, 6, 7, 8, 9, 10, 11, 12, 13, 14 mm | | |
| Deep sockets 1/4"DR, 8 pcs | | 5, 6, 7, 8, 9, 10, 12, 13 mm | | |
| Bit socket 1/4"DR, 12 pcs | | (PH) 1, 2, 3; (H) 3, 4, 5, 6, 7, 8 mm; (SL) 4, 5.5, 7 mm | | |
| Extension 1/4"DR 50 mm | | 50 mm | | |
| Ratchet handle 1/4"DR | | 150 mm, 48 teeth | | |
| Universal joint 1/4"DR | | 35 mm | | |
| Sliding T-bar 1/4"DR | | 110 mm | | |

1/4" tool set

57 pcs



| Code | Item No. | kg | pcs | kg |
|------------------------------|----------|---|-----|-------|
| 52058 | UTS0057 | 1,44 | 10 | 14,40 |
| Content (57 pieces): | | | | |
| Sockets 1/4"DR, 13 pcs | | 4, 4.5, 5, 5.5, 6, 7, 8, 9, 10, 11, 12, 13, 14 mm | | |
| Deep sockets 1/4"DR, 8 pcs | | 6, 7, 8, 9, 10, 11, 12, 13 mm | | |
| TORX® sockets 1/4"DR, 5 pcs | | E4, E5, E6, E7, E8 | | |
| Ratchet handle 1/4"DR | | 150 mm, 48 teeth | | |
| Sliding T-bar 1/4"DR | | 110 mm | | |
| Universal joint 1/4"DR | | 35 mm | | |
| Extension 1/4"DR | | 75 mm | | |
| Flexible extension 1/4"DR | | 150 mm | | |
| Spinner handle 1/4"DR | | 150 mm | | |
| Bit adapter 1/4"DR x 1/4"HDR | | | | |
| Bits 1/4"HDR l=25 mm, 24 pcs | | (PH) 0, 1, 2, 3; (PZ) 0, 1, 2; (H) 3, 4, 5, 6, 7, 8 mm; (T) T8, T9, T10, T15, T20, T25, T27, T30; (SL) 4, 5.5, 7 mm | | |

1/4" & 1/2"DR Universal tool set

56 pcs



| Code | Item No. | kg | pcs | kg |
|----------------------------------|----------|---|-----|-------|
| 52057 | UTS0056 | 6,00 | 4 | 24,00 |
| Content (56 pieces): | | | | |
| Sockets 1/4"DR, 6 pcs | | 8, 9, 10, 11, 12, 13 mm | | |
| Spinner handle 1/4"DR | | 150 mm | | |
| Bit adapter 1/4"DR x 1/4"HDR | | | | |
| Bits 1/4"HDR, l=25 mm, 14 pcs | | (PH) 1, 2, 3; (SL) 3, 4, 5, 6 mm; (TORX®) T10, T15, T20, T25, T27, T30, T40 | | |
| Sockets 1/2"DR, 10 pcs | | 10, 12, 13, 14, 15, 17, 19, 22, 24, 27 mm | | |
| Spark plug sockets 1/2"DR, 2 pcs | | 16, 21 mm | | |
| Ratchet handle 1/2"DR | | 250 mm, 48 teeth | | |
| Extension 1/2"DR | | 125 mm | | |
| Universal joint 1/2"DR | | 70 mm | | |
| HEX keys, 4 pcs | | 1.5, 2, 3, 4 mm | | |
| Combination wrenches, 6 pcs | | 10, 12, 13, 14, 15, 17 mm | | |
| Hammer | | 0,3 kg | | |
| Pliers | | 180 mm | | |
| Adjustable joint pliers | | 250 mm | | |
| Screwdriver, 5 pcs | | (PH) 2 x 38 mm, 2 x 100 mm; (PZ) 3 x 200 mm; (SL) 6 x 38 mm, 6 x 100 mm | | |

1/4" & 1/2"DR Universal tool set

72 pcs



| Code | Item No. | kg | pcs | kg |
|-----------------------------------|----------|---|-----|-------|
| 52059 | UTS0072 | 7,70 | 3 | 23,10 |
| Content (72 pieces): | | | | |
| Sockets 1/4"DR, 10 pcs. | | 4, 5, 6, 7, 8, 9, 10, 11, 12, 13 mm | | |
| Deep sockets 1/4"DR, 5 pcs. | | 5, 6, 7, 8, 10 mm | | |
| Ratchet handle 1/4"DR | | 150 mm, 48 teeth | | |
| Universal joint 1/4"DR | | 35 mm | | |
| Extension 1/4"DR | | 75 mm | | |
| Spinner handle | | 150 mm | | |
| Bit adapter 1/4"DR x 1/4"HDR | | | | |
| Bits 1/4"HDR l=25 mm, 14 pcs. | | (PH) 1, 2, 3; (SL) 3, 4, 5, 6 mm; (TORX®) T10, T15, T20, T25, T27, T30, T40 | | |
| Sockets 1/2"DR, 13 pcs. | | 10, 11, 12, 13, 14, 15, 17, 19, 22, 24, 27, 30, 32 mm | | |
| Spark plug sockets 1/2"DR, 2 pcs. | | 16, 21 mm | | |
| Ratchet handle 1/2"DR | | 250 mm, 48 teeth | | |
| Extension 1/2"DR | | 125 mm | | |
| Universal joint 1/2"DR | | 70 mm | | |
| Hex keys, 3 pcs | | 1.5, 2, 3, mm | | |
| Combination wrenches, 8 pcs. | | 10, 11, 12, 13, 14, 15, 17, 19 mm | | |
| Hammer | | 0,3 kg | | |
| Clamps | | 250 mm | | |
| Pliers | | 180 mm | | |
| Adjustable joint pliers | | 250 mm | | |
| Screwdriver, 5 pcs. | | (PH) 2 x 38 mm, 2 x 100 mm; (PZ) 3 x 200 mm; (SL) 6 x 38 mm, 6 x 100 mm | | |

1/4" & 1/2"DR Universal tool set

77 pcs

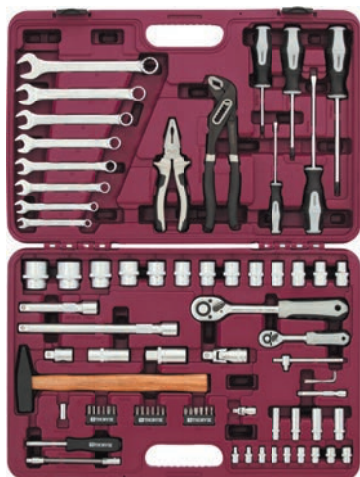

| Code | Item No. | kg | pcs | kg |
|-----------------------------------|----------|---|-----|-------|
| 52802 | UTS0077 | 8,00 | 2 | 16,80 |
| Content (77 pieces): | | | | |
| Sockets 1/4"DR, 9 pcs. | | 4, 5, 6, 7, 8, 9, 10, 11, 12 mm | | |
| Sockets 1/4"DR, 4 pcs. | | 8, 10, 12, 13 mm | | |
| Ratchet handle 1/4"DR | | 150 mm, 48 teeth | | |
| Universal joint 1/4"DR | | 35 mm | | |
| Extension 1/4"DR | | 75 mm | | |
| Flexible extension 1/4"DR | | 150 mm | | |
| Spinner handle 1/4"DR | | 150 mm | | |
| Bit adapter 1/4"DR x 1/4"HDR | | | | |
| Bits 1/4"HDR l=25 mm, 18 pcs. | | (PH) 1, 2, 3; (SL) 3, 4, 5, 6; (H) 3, 4, 5, 6 mm; (T) T10, T15, T20, T25, T27, T30, T40 | | |
| Sockets 1/2"DR, 13 pcs. | | 12, 13, 14, 15, 17, 18, 19, 21, 22, 24, 27, 30, 32 mm | | |
| Spark plug sockets 1/2"DR, 2 pcs. | | 16, 21 mm | | |
| Ratchet handle 1/2"DR | | 250 mm, 48 teeth | | |
| Universal joint 1/2"DR | | 70 mm | | |
| Extension 1/2"DR, 2 pcs. | | 125, 250 mm | | |
| 3-way adapter 1/2"DR | | | | |
| Hex keys, 3 pcs. | | 1.5, 2, 3, mm | | |
| Combination wrenches, 8 pcs. | | 8, 10, 12, 13, 14, 15, 17, 19 mm | | |
| Hammer | | 0,3 KG | | |
| Pliers | | 180 mm | | |
| Adjustable joint pliers | | 250 mm | | |
| Screwdriver, 5 pcs. | | (PH) 1 x 75 mm, 2 x 100 mm, 3 x 150 mm; (SL) 4 x 100 mm, 6 x 150 mm | | |

1/4" & 1/2"DR Universal tool set with 12-point sockets

77 pcs



| Code | Item No. | kg | pcs | kg |
|-----------------------------------|------------|---|-----|-------|
| 52803 | UTS0077/12 | 8,00 | 2 | 16,80 |
| Content (77 pieces): | | | | |
| 12-point sockets 1/4"DR, 9 pcs. | | 4, 5, 6, 7, 8, 9, 10, 11, 12 mm | | |
| 12-point sockets 1/4"DR, 4 pcs. | | 8, 10, 12, 13 mm | | |
| Ratchet handle 1/4"DR | | 150 mm, 48 teeth | | |
| Universal joint 1/4"DR | | 35 mm | | |
| Extension 1/4"DR | | 75 mm | | |
| Flexible extension 1/4"DR | | 150 mm | | |
| Spinner handle 1/4"DR | | 150 mm | | |
| Bit adapter 1/4"DR x 1/4"HDR | | | | |
| Bits 1/4"HDR l=25 mm, 18 pcs. | | (PH) 1, 2, 3; (SL) 3, 4, 5, 6; (H) 3, 4, 5, 6 mm; (T) T10, T15, T20, T25, T27, T30, T40 | | |
| 12-point sockets 1/2"DR, 13 pcs. | | 12, 13, 14, 15, 17, 18, 19, 21, 22, 24, 27, 30, 32 mm | | |
| Spark plug sockets 1/2"DR, 2 pcs. | | 16, 21 mm | | |
| Ratchet handle 1/2"DR | | 250 mm, 48 teeth | | |
| Universal joint 1/2"DR | | 70 mm | | |
| Extension 1/2"DR, 2 pcs. | | 125, 250 mm | | |
| 3-way adapter 1/2"DR | | | | |
| Hex keys, 3 pcs. | | 1.5, 2, 3, mm | | |
| Combination wrenches, 8 pcs. | | 8, 10, 12, 13, 14, 15, 17, 19 mm | | |
| Hammer | | 0,3 KG | | |
| Pliers | | 180 mm | | |
| Adjustable joint pliers | | 250 mm | | |
| Screwdriver, 5 pcs. | | (PH) 1 x 75 mm, 2 x 100 mm, 3 x 150 mm; (SL) 4 x 100 mm, 6 x 150 mm | | |

1/4" & 1/2"DR Universal tool set with MultiProf sockets

77 pcs

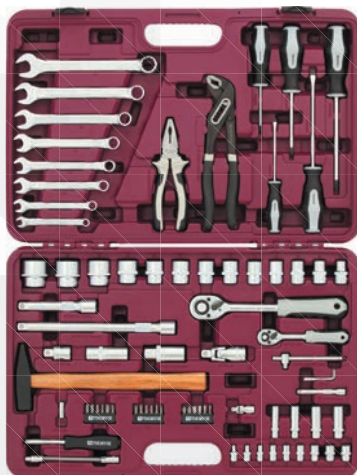

| Code | Item No. | kg | pcs | kg |
|-----------------------------------|-----------|---|-----|-------|
| 52804 | UTS0077MP | 8,00 | 2 | 16,80 |
| Content (77 pieces): | | | | |
| MultiProf sockets 1/4"DR, 9 pcs. | | 4, 5, 6, 7, 8, 9, 10, 11, 12 mm | | |
| MultiProf sockets 1/4"DR, 4 pcs. | | 8, 10, 12, 13 mm | | |
| Ratchet handle 1/4"DR | | 150 mm, 48 teeth | | |
| Universal joint 1/4"DR | | 35 mm | | |
| Extension 1/4"DR | | 75 mm | | |
| Flexible extension 1/4"DR | | 150 mm | | |
| Spinner handle 1/4"DR | | 150 mm | | |
| Bit adapter 1/4"DR x 1/4"HDR | | | | |
| Bits 1/4"HDR l=25 mm, 18 pcs. | | (PH) 1, 2, 3; (SL) 3, 4, 5, 6; (H) 3, 4, 5, 6 mm; (T) T10, T15, T20, T25, T27, T30, T40 | | |
| MultiProf sockets 1/2"DR, 13 pcs. | | 12, 13, 14, 15, 17, 18, 19, 21, 22, 24, 27, 30, 32 mm | | |
| Spark plug sockets 1/2"DR, 2 pcs. | | 16, 21 mm | | |
| Ratchet handle 1/2"DR | | 250 mm, 48 teeth | | |
| Universal joint 1/2"DR | | 70 mm | | |
| Extension 1/2"DR, 2 pcs. | | 125, 250 mm | | |
| 3-way adapter 1/2"DR | | | | |
| Hex keys, 3 pcs. | | 1.5, 2, 3, mm | | |
| Combination wrenches, 8 pcs. | | 8, 10, 12, 13, 14, 15, 17, 19 mm | | |
| Hammer | | 0,3 KG | | |
| Pliers | | 180 mm | | |
| Adjustable joint pliers | | 250 mm | | |
| Screwdriver, 5 pcs. | | (PH) 1 x 75 mm, 2 x 100 mm, 3 x 150 mm; (SL) 4 x 100 mm, 6 x 150 mm | | |

1/4" & 1/2"DR Universal tool set

82 pcs



| Code | Item No. | kg | pcs | kg |
|-------------------------------------|----------|---|-----|-------|
| 52060 | UTS0082 | 6,00 | 4 | 24,00 |
| Content (82 pieces): | | | | |
| Sockets 1/4"DR, 13 pcs. | | 4, 4.5, 5, 5.5, 6, 7, 8, 9, 10, 11, 12, 13, 14 mm | | |
| Ratchet handle 1/4"DR | | 150 mm, 48 teeth | | |
| Sliding T-bar 1/4"DR | | 110 mm | | |
| Universal joint 1/4"DR | | 35 mm | | |
| Extension 1/4"DR, 2 pcs. | | 50, 100 mm | | |
| Flexible extension 1/4"DR | | 150 mm | | |
| Spinner handle 1/4"DR | | 150 mm | | |
| Bit adapter | | HDR 1/4" x SDR 1/4" | | |
| Bit socket 1/4"DR, l=25 mm, 17 pcs. | | (PH) 1, 2; (PZ) 1, 2; (H) 3, 4, 5, 6 mm; (SL) 4, 5.5, 7 mm; (T) T8, T10, T15, T20, T25, T30 | | |
| Sockets 1/2"DR, 12 pcs | | 14, 15, 16, 17, 18, 19, 21, 22, 24, 27, 30, 32 mm | | |
| Spark plug sockets 1/2"DR, 2 pcs. | | 16, 21 mm | | |
| Ratchet handle 1/2"DR | | 250 mm, 48 teeth | | |
| Extension 1/2"DR, 2 pcs. | | 125, 250 mm | | |
| Universal joint 1/2"DR | | 70 mm | | |
| 3-way adapter 1/2"DR | | | | |
| Bit adapter 1/2"DR x 5/16"HDR | | | | |
| Bits 5/16" HDR, l=30 mm, 15 pcs. | | (PH) 3, 4; (PZ) 3, 4; (T) T40, T45, T50, T55; (SL) 8, 10, 12 mm; (H) 8, 10, 12, 14 mm | | |
| Combination wrenches, 9 pcs. | | 8, 10, 11, 12, 13, 14, 17, 19, 22 mm | | |

1/4" & 1/2"DR Universal tool set with 12-point sockets

82 pcs



| Code | Item No. | kg | pcs | kg |
|-------------------------------------|------------|---|-----|-------|
| 52805 | UTS0082/12 | 5,68 | 4 | 23,50 |
| Content (82 pieces): | | | | |
| 12-point sockets 1/4"DR, 13 pcs. | | 4, 4.5, 5, 5.5, 6, 7, 8, 9, 10, 11, 12, 13, 14 mm | | |
| Ratchet handle 1/4"DR | | 150 mm, 48 teeth | | |
| Sliding T-bar 1/4"DR | | 110 mm | | |
| Universal joint 1/4"DR | | 35 mm | | |
| Extension 1/4"DR, 2 pcs. | | 50, 100 mm | | |
| Flexible extension 1/4"DR | | 150 mm | | |
| Spinner handle 1/4"DR | | 150 mm | | |
| Bit adapter | | HDR 1/4" x SDR 1/4" | | |
| Bit socket 1/4"DR, l=25 mm, 17 pcs. | | (PH) 1, 2; (PZ) 1, 2; (H) 3, 4, 5, 6 mm; (SL) 4, 5.5, 7 mm; (T) T8, T10, T15, T20, T25, T30 | | |
| 12-point sockets 1/2"DR, 12 pcs. | | 14, 15, 16, 17, 18, 19, 21, 22, 24, 27, 30, 32 mm | | |
| Spark plug sockets 1/2"DR, 2 pcs. | | 16, 21 mm | | |
| Ratchet handle 1/2"DR | | 250 mm, 48 teeth | | |
| Extension 1/2"DR, 2 pcs. | | 125, 250 mm | | |
| Universal joint 1/2"DR | | 70 mm | | |
| 3-way adapter 1/2"DR | | | | |
| Bit adapter 1/2"DR x 5/16"HDR | | | | |
| Bits 5/16" HDR, l=30 mm, 15 pcs. | | (PH) 3, 4; (PZ) 3, 4; (T) T40, T45, T50, T55; (SL) 8, 10, 12 mm; (H) 8, 10, 12, 14 mm | | |
| Combination wrenches, 9 pcs. | | 8, 10, 11, 12, 13, 14, 17, 19, 22 mm | | |

1/4" & 1/2"DR Universal tool set with MultiProf sockets

82 pcs



| Code | Item No. | kg | pcs | kg |
|--|-----------|---|-----|-------|
| 52806 | UTS0082MP | 5,63 | 4 | 23,30 |
| Content (82 pieces): | | | | |
| MultiProf sockets 1/4"DR, 13 pcs. | | 4, 4.5, 5, 5.5, 6, 7, 8, 9, 10, 11, 12, 13, 14 mm | | |
| Ratchet handle 1/4"DR | | 150 mm, 48 teeth | | |
| Sliding T-bar 1/4"DR | | 110 mm | | |
| Universal joint 1/4"DR | | 35 mm | | |
| Extension 1/4"DR, 2 pcs. | | 50, 100 mm | | |
| Flexible extension 1/4"DR | | 150 mm | | |
| Spinner handle 1/4"DR | | 150 mm | | |
| Bit adapter | | HDR 1/4" x SDR 1/4" | | |
| Bit socket 1/4"DR, l=25 mm, 17 pcs. | | (PH) 1, 2; (PZ) 1, 2; (H) 3, 4, 5, 6 mm; (SL) 4, 5.5, 7 mm; (T) T8, T10, T15, T20, T25, T30 | | |
| MultiProf sockets 1/2"DR, 12 pcs. | | 14, 15, 16, 17, 18, 19, 21, 22, 24, 27, 30, 32 mm | | |
| Spark plug sockets 1/2"DR, 2 pcs. | | 16, 21 mm | | |
| Ratchet handle 1/2"DR | | 250 mm, 48 teeth | | |
| Extension 1/2"DR, 2 pcs. | | 125, 250 mm | | |
| Universal joint 1/2"DR | | 70 mm | | |
| 3-way adapter 1/2"DR | | | | |
| Bit adapter 1/2"DR x 5/16"HDR | | | | |
| Bits 5/16" HDR, l=30 mm, 15 pcs. | | (PH) 3, 4; (PZ) 3, 4; (T) T40, T45, T50, T55; (SL) 8, 10, 12 mm; (H) 8, 10, 12, 14 mm | | |
| MultiProf combination wrenches, 9 pcs. | | 8, 10, 11, 12, 13, 14, 17, 19, 22 mm | | |

1/4" & 1/2"DR Universal tool set

94 pcs



| Code | Item No. | kg | pcs | kg |
|-----------------------------------|----------|---|-----|-------|
| 52061 | UTS0094 | 6,20 | 4 | 24,80 |
| Content (94 pieces): | | | | |
| Sockets 1/4"DR, 13 pcs. | | 4, 4.5, 5, 5.5, 6, 7, 8, 9, 10, 11, 12, 13, 14 mm | | |
| Deep sockets 1/4"DR, 8 pcs. | | 6, 7, 8, 9, 10, 11, 12, 13 mm | | |
| Ratchet handle 1/4"DR | | 150 mm, 48 teeth | | |
| Universal joint 1/4"DR | | 35 mm | | |
| Sliding T-bar 1/4"DR | | 110 mm | | |
| Extension 1/4"DR, 2 pcs. | | 50, 100 mm | | |
| Spinner handle 1/4"DR | | 150 mm | | |
| Bit socket 1/4"DR, 18 pcs. | | (PH) 1, 2; (PZ) 1, 2; (H) 3, 4, 5, 6 mm; (SL) 4, 5.5, 6.5; (T) T8, T10, T15, T20, T25, T27, T30 | | |
| Sockets 1/2"DR, 17 pcs. | | 10, 11, 12, 13, 14, 15, 16, 17, 18, 19, 20, 21, 22, 24, 27, 30, 32 mm | | |
| Deep sockets 1/2"DR, 5 pcs. | | 14, 15, 17, 19, 22 mm | | |
| Spark plug sockets 1/2"DR, 2 pcs. | | 16, 21 mm | | |
| Ratchet handle 1/2"DR | | 250 mm, 48 teeth | | |
| Universal joint 1/2"DR | | 70 mm | | |
| Extension 1/2"DR, 2 pcs. | | 125, 250 mm | | |
| 3-way adapter 1/2"DR | | | | |
| Bit adapter 1/2"DR x 5/16"HDR | | | | |
| Bits 5/16"HDR, l=30 mm, 16 pcs. | | (PH) 3, 4; (PZ) 3, 4; (SL) 8, 10, 12 mm; (T) T40, T45, T50, T55; (H) 7, 8, 10, 12, 14 mm | | |
| Hex keys, 3 pcs. | | 1.5, 2, 2.5 mm | | |

Universal tool set with 12-point sockets

94 pcs



| Code | Item No. | kg | pcs | kg |
|-----------------------------------|------------|---|-----|-------|
| 52807 | UTS0094/12 | 5,98 | 4 | 24,70 |
| Content (94 pieces): | | | | |
| 12-point sockets 1/4"DR, 13 pcs. | | 4, 4.5, 5, 5.5, 6, 7, 8, 9, 10, 11, 12, 13, 14 mm | | |
| 12-point sockets 1/4"DR, 8 pcs. | | 6, 7, 8, 9, 10, 11, 12, 13 mm | | |
| Ratchet handle 1/4"DR | | 150 mm, 48 teeth | | |
| Universal joint 1/4"DR | | 35 mm | | |
| Sliding T-bar 1/4"DR | | 110 mm | | |
| Extension 1/4"DR, 2 pcs . | | 50, 100 mm | | |
| Spinner handle 1/4"DR | | 150 mm | | |
| Bit socket 1/4"DR, 18 pcs. | | (PH) 1, 2; (PZ) 1, 2; (H) 3, 4, 5, 6 mm; (SL) 4, 5.5, 6.5; (T) T8, T10, T15, T20, T25, T27, T30 | | |
| 12-point sockets 1/2"DR, 17 pcs. | | 10, 11, 12, 13, 14, 15, 16, 17, 18, 19, 20, 21, 22, 24, 27, 30, 32 mm | | |
| Deep sockets 1/2"DR, 5 pcs. | | 14, 15, 17, 19, 22 mm | | |
| Spark plug sockets 1/2"DR, 2 pcs. | | 16, 21 mm | | |
| Ratchet handle 1/2"DR | | 250 mm, 48 teeth | | |
| Universal joint 1/2"DR | | 70 mm | | |
| Extension 1/2"DR, 2 pcs. | | 125, 250 mm | | |
| 3-way adapter 1/2"DR | | | | |
| Bit adapter 1/2"DR x 5/16"HDR | | | | |
| Bits 5/16"HDR, l=30 mm, 16 pcs. | | (PH) 3, 4; (PZ) 3, 4; (SL) 8, 10, 12 mm; (T) T40, T45, T50, T55; (H) 7, 8, 10, 12, 14 mm | | |
| Hex keys, 3 pcs. | | 1.5, 2, 2.5 mm | | |

1/4" & 1/2"DR Universal tool set with MultiProf sockets

94 pcs



| Code | Item No. | kg | pcs | kg |
|---------------------------------------|-----------|---|-----|-------|
| 52808 | UTS0094MP | 5,95 | 4 | 24,60 |
| Content (94 pieces): | | | | |
| MultiProf sockets 1/4"DR, 13 pcs. | | 4, 4.5, 5, 5.5, 6, 7, 8, 9, 10, 11, 12, 13, 14 mm | | |
| MultiProf sockets 1/4"DR, 8 pcs. | | 6, 7, 8, 9, 10, 11, 12, 13 mm | | |
| Ratchet handle 1/4"DR | | 150 mm, 48 teeth | | |
| Universal joint 1/4"DR | | 35 mm | | |
| Sliding T-bar 1/4"DR | | 110 mm | | |
| Extension 1/4"DR, 2 pcs . | | 50, 100 mm | | |
| Spinner handle 1/4"DR | | 150 mm | | |
| Bit socket 1/4"DR, 18 pcs. | | (PH) 1, 2; (PZ) 1, 2; (H) 3, 4, 5, 6 mm; (SL) 4, 5.5, 6.5mm; (T) T8, T10, T15, T20, T25, T27, T30 | | |
| MultiProf sockets 1/2"DR, 17 pcs. | | 10, 11, 12, 13, 14, 15, 16, 17, 18, 19, 20, 21, 22, 24, 27, 30, 32 mm | | |
| MultiProf deep sockets 1/2"DR, 5 pcs. | | 14, 15, 17, 19, 22 mm | | |
| Spark plug sockets 1/2"DR, 2 pcs. | | 16, 21 mm | | |
| Ratchet handle 1/2"DR | | 250 mm, 48 teeth | | |
| Universal joint 1/2"DR | | 70 mm | | |
| Extension 1/2"DR, 2 pcs. | | 125, 250 mm | | |
| 3-way adapter 1/2"DR | | | | |
| Bit adapter 1/2"DR x 5/16"HDR | | | | |
| Bits 5/16"HDR, l=30 mm, 16 pcs. | | (PH) 3, 4; (PZ) 3, 4; (SL) 8, 10, 12 mm; (T) T40, T45, T50, T55; (H) 7, 8, 10, 12, 14 mm | | |
| Hex keys, 3 pcs. | | 1.5, 2, 2.5 mm | | |

1/4" & 1/2"DR Universal tool set

101 pcs

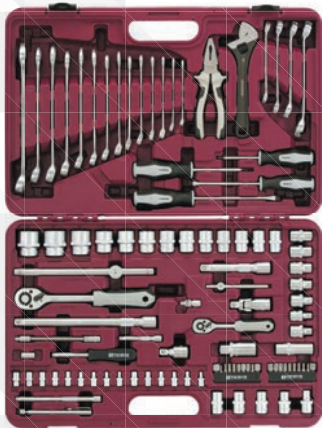

| Code | Item No. | kg | pcs | kg |
|-----------------------------------|----------|---|-----|-------|
| 52799 | UTS0101 | 9,87 | 2 | 20,53 |
| Content (101 pieces): | | | | |
| Sockets 1/4"DR, 9 pcs. | | 4, 4.5, 5, 5.5, 6, 7, 8, 9, 10 mm | | |
| TORX® sockets 1/4"DR, 6 pcs. | | E4, E5, E6, E7, E8, E10 | | |
| Ratchet handle 1/4"DR | | 150 mm, 48 teeth | | |
| Sliding T-bar 1/4"DR | | 110 mm | | |
| Universal joint 1/4"DR | | 35 mm | | |
| Extension 1/4"DR, 2 pcs. | | 75, 150 mm | | |
| Flexible extension 1/4"DR | | 150 mm | | |
| Spinner handle 1/4"DR | | 150 mm | | |
| Bit adapter 1/4"DR x 1/4"HDR | | | | |
| Bits 1/4"HDR l=25 mm, 20 pcs. | | (H) 3, 4, 5, 6, 7, 8, 10, 12 mm; (T) T15, T20, T25, T27, T30, T40, T45, T50; (XZN) M6, M8, M10, M12 | | |
| Sockets 1/2"DR, 20 pcs. | | 8, 9, 10, 11, 12, 13, 14, 15, 16, 17, 18, 19, 20, 21, 22, 23, 24, 27, 30, 32 mm | | |
| TORX® sockets 1/2"DR, 5 pcs. | | E11, E12, E14, E16, E18 | | |
| Spark plug sockets 1/2"DR, 2 pcs. | | 16, 21 mm | | |
| Ratchet handle 1/2"DR | | 250 mm, 48 teeth | | |
| Universal joint 1/2"DR | | 70 mm | | |
| Extension 1/2"DR, 2 pcs. | | 125 и 250 mm | | |
| Extension ball point 1/2"DR | | 50 mm | | |
| Combination wrenches, 14 pcs. | | 8, 10, 11, 12, 13, 14, 15, 16, 17, 18, 19, 21, 22, 24 mm | | |
| Flare nut wrenches, 4 pcs. | | 8x10, 11x13, 12x14, 17x19 mm | | |
| Pliers | | 180 mm | | |
| Adjustable wrench | | 200 mm | | |
| Screwdriver, 4 pcs. | | (PH) 1x75 mm, 2x100 mm; (SL) 5x125 mm, 6x150 mm | | |
| Magnetic pick up tool | | | | |

1/4" & 1/2"DR Universal tool set

108 pcs

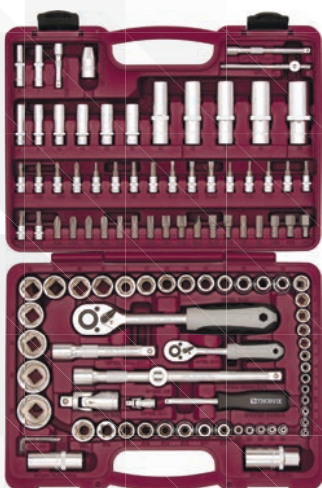

| Code | Item No. | kg | pcs | kg |
|----------------------------------|----------|--|-----|-------|
| 52062 | UTS0108 | 6,82 | 4 | 27,30 |
| Content (108 pieces): | | | | |
| Sockets 1/4"DR, 13 pcs | | 4, 4.5, 5, 5.5, 6, 7, 8, 9, 10, 11, 12, 13, 14 mm | | |
| Deep sockets 1/4"DR, 8 pcs | | 6, 7, 8, 9, 10, 11, 12, 13 mm | | |
| TORX® sockets 1/4"DR, 5 pcs | | E4, E5, E6, E7, E8 | | |
| Ratchet handle 1/4"DR | | 150 mm, 48 teeth | | |
| Sliding T-bar 1/4"DR | | 110 mm | | |
| Universal joint 1/4"DR | | 35 mm | | |
| Extension 1/4"DR, 2 pcs | | 50, 100 mm | | |
| Spinner handle 1/4"DR | | 150 mm | | |
| Bit socket 1/4"DR, 18 pcs | | (PH) 1, 2; (PZ) 1, 2; (H) 3, 4, 5, 6 mm; (SL) 4, 5.5, 6.5 mm; (T) T8, T10, T15, T20, T25, T27, T30 | | |
| Sockets 1/2"DR, 17 pcs | | 10, 11, 12, 13, 14, 15, 16, 17, 18, 19, 20, 21, 22, 24, 27, 30, 32 mm | | |
| Deep sockets 1/2"DR, 5 pcs | | 14, 15, 17, 19, 22 mm | | |
| TORX® sockets 1/2"DR, 8 pcs | | E10, E11, E12, E14, E16, E18, E20, E24 | | |
| Spark plug sockets 1/2"DR, 2 pcs | | 16, 21 mm | | |
| Ratchet handle 1/2"DR | | 250 mm, 48 teeth | | |
| Universal joint 1/2"DR | | 70 mm | | |
| Extension 1/2"DR, 2 pcs | | 125, 250 mm | | |
| 3-way adapter 1/2"DR | | | | |
| Bit adapter 1/2"DR x 5/16"HDR | | | | |
| Bits 5/16"HDR l=30 mm, 17 pcs | | (PH) 3, 4; (PZ) 3, 4; (T) T40, T45, T50, T55, T60; (SL) 8, 10, 12 mm; (H) 7, 8, 10, 12, 14 mm | | |
| Hex keys, 3 pcs | | 1.5, 2, 2.5 mm | | |

1/4" & 1/2"DR Universal tool set with 12-point sockets

108 pcs



| Code | Item No. | kg | pcs | kg |
|--------------------------------------|-----------|--|-----|-------|
| 52809 | UTS108/12 | 6,50 | 4 | 26,80 |
| Content (108 pieces): | | | | |
| 12-point sockets 1/4"DR, 13 pcs. | | 4, 4.5, 5, 5.5, 6, 7, 8, 9, 10, 11, 12, 13, 14 mm | | |
| 12-point deep sockets 1/4"DR, 8 pcs. | | 6, 7, 8, 9, 10, 11, 12, 13 mm | | |
| TORX® sockets 1/4"DR, 5 pcs. | | E4, E5, E6, E7, E8 | | |
| Ratchet handle 1/4"DR | | 150 mm, 48 teeth | | |
| Sliding T-bar 1/4"DR | | 110 mm | | |
| Universal joint 1/4"DR | | 35 mm | | |
| Extension 1/4"DR, 2 pcs. | | 50, 100 mm | | |
| Spinner handle 1/4"DR | | 150 mm | | |
| Bit socket 1/4"DR, 18 pcs. | | (PH) 1, 2; (PZ) 1, 2; (H) 3, 4, 5, 6 mm; (SL) 4, 5.5, 6.5 mm; (T) T8, T10, T15, T20, T25, T27, T30 | | |
| 12-point sockets 1/2"DR, 17 pcs. | | 10, 11, 12, 13, 14, 15, 16, 17, 18, 19, 20, 21, 22, 24, 27, 30, 32 mm | | |
| 12-point deep sockets 1/2"DR, 5 pcs. | | 14, 15, 17, 19, 22 mm | | |
| TORX® sockets 1/2"DR, 8 pcs. | | E10, E11, E12, E14, E16, E18, E20, E24 | | |
| Spark plug sockets 1/2"DR, 2 pcs. | | 16, 21 mm | | |
| Ratchet handle 1/2"DR | | 250 mm, 48 teeth | | |
| Universal joint 1/2"DR | | 70 mm | | |
| Extension 1/2"DR, 2 pcs. | | 125, 250 mm | | |
| 3-way adapter 1/2"DR | | | | |
| Bit adapter 1/2"DR x 5/16"HDR | | | | |
| Bits 5/16"HDR l=30 mm, 17 pcs. | | (PH) 3, 4; (PZ) 3, 4; (T) T40, T45, T50, T55, T60; (SL) 8, 10, 12 mm; (H) 7, 8, 10, 12, 14 mm | | |
| Hex keys, 3 pcs. | | 1.5, 2, 2.5 mm | | |

1/4" & 1/2"DR Universal tool set with MultiProf sockets

108 pcs



| Code | Item No. | kg | pcs | kg |
|---------------------------------------|-----------|--|-----|-------|
| 52810 | UTS0108MP | 6,55 | 4 | 27,00 |
| Content (108 pieces): | | | | |
| MultiProf sockets 1/4"DR, 13 pcs. | | 4, 4.5, 5, 5.5, 6, 7, 8, 9, 10, 11, 12, 13, 14 mm | | |
| MultiProf deep sockets 1/4"DR, 8 pcs. | | 6, 7, 8, 9, 10, 11, 12, 13 mm | | |
| TORX® sockets 1/4"DR, 5 pcs. | | E4, E5, E6, E7, E8 | | |
| Ratchet handle 1/4"DR | | 150 mm, 48 teeth | | |
| Sliding T-bar 1/4"DR | | 110 mm | | |
| Universal joint 1/4"DR | | 35 mm | | |
| Extension 1/4"DR, 2 pcs. | | 50, 100 mm | | |
| Spinner handle 1/4"DR | | 150 mm | | |
| Bit socket 1/4"DR, 18 pcs. | | (PH) 1, 2; (PZ) 1, 2; (H) 3, 4, 5, 6 mm; (SL) 4, 5.5, 6.5 mm; (T) T8, T10, T15, T20, T25, T27, T30 | | |
| MultiProf sockets 1/2"DR, 17 pcs. | | 10, 11, 12, 13, 14, 15, 16, 17, 18, 19, 20, 21, 22, 24, 27, 30, 32 mm | | |
| MultiProf deep sockets 1/2"DR, 5 pcs. | | 14, 15, 17, 19, 22 mm | | |
| TORX® sockets 1/2"DR, 8 pcs. | | E10, E11, E12, E14, E16, E18, E20, E24 | | |
| Spark plug sockets 1/2"DR, 2 pcs. | | 16, 21 mm | | |
| Ratchet handle 1/2"DR | | 250 mm, 48 teeth | | |
| Universal joint 1/2"DR | | 70 mm | | |
| Extension 1/2"DR, 2 pcs. | | 125, 250 mm | | |
| 3-way adapter 1/2"DR | | | | |
| Bit adapter 1/2"DR x 5/16"HDR | | | | |
| Bits 5/16"HDR l=30 mm, 17 pcs. | | (PH) 3, 4; (PZ) 3, 4; (T) T40, T45, T50, T55, T60; (SL) 8, 10, 12 mm; (H) 7, 8, 10, 12, 14 mm | | |
| Hex keys, 3 pcs. | | 1.5, 2, 2.5 mm | | |

1/4" & 1/2"DR Universal tool set

127 pcs



| Code | Item No. | kg | pcs | kg |
|-------------------------------------|----------|---|-----|-------|
| 52800 | UTS0127 | 15,67 | 1 | 16,44 |
| Content (127 pieces): | | | | |
| Sockets 1/4"DR, 12 pcs. | | 4, 4.5, 5, 5.5, 6, 7, 8, 9, 10, 11, 12, 13 mm | | |
| Deep sockets 1/4"DR, 5 pcs. | | 7, 8, 10, 12, 13 mm | | |
| TORX® sockets 1/4"DR, 5 pcs. | | E4, E5, E6, E7, E8 | | |
| Ratchet handle 1/4"DR | | 150 mm, 48 teeth | | |
| Sliding T-bar 1/4"DR | | 110 mm | | |
| Universal joint 1/4"DR | | 35 mm | | |
| Extension 1/4"DR | | 75 mm | | |
| Extension ball point 1/4"DR, 2 pcs. | | 50, 150 mm | | |
| Flexible extension 1/4"DR | | 150 mm | | |
| Sockets 1/2"DR, 18 pcs. | | 8, 9, 10, 11, 12, 13, 14, 15, 16, 17, 18, 19, 21, 22, 24, 27, 30, 32 mm | | |
| Deep sockets 1/2"DR, 7 pcs. | | 10, 12, 13, 14, 15, 17, 19 mm | | |
| TORX® sockets 1/2"DR, 8 pcs. | | E10, E12, E14, E16, E18, E20, E22, E24 | | |
| Spark plug sockets 1/2"DR, 2 pcs. | | 16, 21 mm | | |
| Ratchet handle 1/2"DR | | 250 mm, 48 teeth | | |
| Universal joint 1/2"DR | | 70 mm | | |
| Extension 1/2"DR, 2 pcs. | | 125 и 250 mm | | |
| Sliding T-bar 1/2"DR | | 250 mm | | |
| Flexible handle 1/2"DR | | 380 mm | | |
| Extension ball point 1/2"DR, 2 pcs. | | 125, 250 mm | | |
| Extension ball point 1/2"DR | | 50 mm | | |
| Combination wrenches, 19 pcs. | | 6, 7, 8, 9, 10, 11, 12, 13, 14, 15, 16, 17, 19, 21, 22, 24, 27, 30, 32 mm | | |
| Flare nut wrenches, 5 pcs. | | 8x10, 9x11, 12x13, 14x17, 17x19 mm | | |
| Hex keys set, 9 pcs. | | 1.5, 2, 2.5, 3, 4, 5, 6, 8, 10 mm | | |
| TORX® Key set 7 pcs | | T10, T15, T20, T25, T27, T30, T40 | | |
| Chisel & punch set, 5 pcs. | | | | |
| Hammer | | 0,5 KG | | |
| Pliers | | 180 mm | | |
| Diagonal cutting pliers | | 160 mm | | |
| Adjustable joint pliers | | 250 mm | | |
| Screwdriver, 6 pcs. | | (PH) 1x75 mm, 2x38 mm, 2x100 mm; (SL) 5x38 mm, 5x75 mm, 6x100 mm | | |
| Magnetic pick up tool | | | | |



1/4" & 1/2"DR Universal tool set

128 pcs

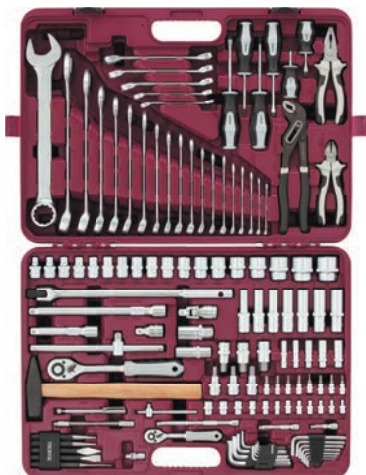

| Code | Item No. | kg | pcs | kg |
|-------------------------------------|----------|---|-----|-------|
| 52801 | UTS0128 | 15,77 | 1 | 16,54 |
| Content (128 pieces): | | | | |
| Sockets 1/4"DR, 12 pcs. | | 4, 4.5, 5, 5.5, 6, 7, 8, 9, 10, 11, 12, 13 mm | | |
| Deep sockets 1/4"DR, 5 pcs. | | 7, 8, 10, 12, 13 mm | | |
| Ratchet handle 1/4"DR | | 150 mm, 48 teeth | | |
| Sliding T-bar 1/4"DR | | 110 mm | | |
| Universal joint 1/4"DR | | 35 mm | | |
| Extension 1/4"DR | | 75 mm | | |
| Extension ball point 1/4"DR, 2 pcs. | | 50, 150 mm | | |
| Flexible extension 1/4"DR | | 150 mm | | |
| Bit socket 1/4"DR, 8 pcs. | | (H) 4, 5, 6; (T) T10, T15, T20, T25, T27 | | |
| Sockets 1/2"DR, 18 pcs. | | 8, 9, 10, 11, 12, 13, 14, 15, 16, 17, 18, 19, 21, 22, 24, 27, 30, 32 mm | | |
| Deep sockets 1/2"DR, 7 pcs. | | 10, 12, 13, 14, 15, 17, 19 mm | | |
| Spark plug sockets 1/2"DR, 2 pcs. | | 16, 21 mm | | |
| Ratchet handle 1/2"DR | | 250 mm, 48 teeth | | |
| Universal joint 1/2"DR | | 70 mm | | |
| Extension 1/2"DR, 2 pcs. | | 125, 250 mm | | |
| Sliding T-bar 1/2"DR | | 250 mm | | |
| Flexible handle 1/2"DR | | 380 mm | | |
| Extension ball point 1/2"DR, 2 pcs. | | 125, 250 mm | | |
| Extension ball point 1/2"DR | | 50 mm | | |
| Bit socket 1/2"DR, 6 pcs. | | (H) 7, 8, 10, 12, 14, 17 | | |
| Combination wrenches, 19 pcs. | | 6, 7, 8, 9, 10, 11, 12, 13, 14, 15, 16, 17, 19, 21, 22, 24, 27, 30, 32 mm | | |
| Flare nut wrenches, 5 pcs. | | 8x10, 9x11, 12x13, 14x17, 17x19 mm | | |
| Hex keys set, 9 pcs. | | 1.5, 2, 2.5, 3, 4, 5, 6, 8, 10 mm | | |
| Набор ключей торцевых TORX®, 7 пр. | | T10, T15, T20, T25, T27, T30, T40 | | |
| Chisel & punch set, 5 pcs. | | | | |
| Hammer | | 0,5 KG | | |
| Pliers | | 180 mm | | |
| Diagonal cutting pliers | | 160 mm | | |
| Adjustable joint pliers | | 250 mm | | |
| Screwdriver, 6 pcs. | | (PH) 1x75 mm, 2x38 mm, 2x100 mm; (SL) 5x38 mm, 5x75 mm, 6x100 mm | | |
| Magnetic pick up tool | | | | |



1/4", 3/8" & 1/2"DR Universal tool set

142 pcs

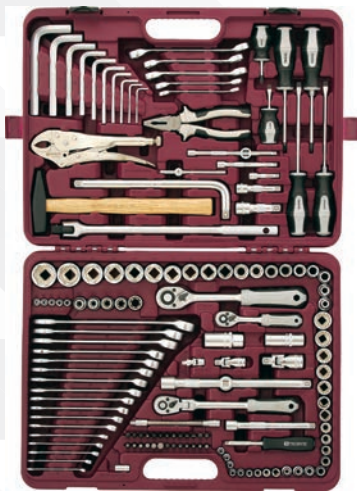

| Code | Item No. | kg | pcs | kg |
|----------------------------------|----------|---|-----|-------|
| 52063 | UTS0142 | 14,00 | 2 | 28,00 |
| Content (142 pieces): | | | | |
| Sockets 1/4"DR, 9 pcs | | 4, 4.5, 5, 5.5, 6, 7, 8, 9, 10 mm | | |
| TORX® sockets 1/4"DR, 5 pcs | | E4, E5, E6, E7, E8 | | |
| Ratchet handle 1/4"DR | | 150 mm, 48 teeth | | |
| Sliding T-bar 1/4"DR | | 110 mm | | |
| Universal joint 1/4"DR | | 35 mm | | |
| Extension 1/4"DR, 3 pcs | | 50, 100, 150 mm | | |
| Flexible extension 1/4"DR | | 150 mm | | |
| Spinner handle 1/4"DR | | 150 mm | | |
| Bit adapter 1/4"DR x 1/4"HDR | | | | |
| Bits 1/4"HDR l=25 mm, 26 pcs | | (PH) 0, 1, 2, 3; (PZ) 0, 1, 2, 3; (SL) 4, 5.5, 7; (H) 2, 3, 4, 5, 6, 7, 8, 10 mm; (T) T10, T15, T20, T25, T27, T30, T40 | | |
| Sockets 12-points 3/8"DR, 15 pcs | | 6, 7, 8, 9, 10, 11, 12, 13, 14, 15, 17, 18, 19, 21, 22 mm | | |
| Flexible ratchet handle 3/8"DR | | 250 mm, 48 teeth | | |
| Extension 3/8"DR, 2 pcs | | 75, 150 mm | | |
| Universal joint 3/8"DR | | 50 mm | | |
| 3-way adapter 3/8"DR | | | | |
| Sockets 1/2"DR, 19 pcs | | 8, 10, 12, 13, 14, 15, 16, 17, 18, 19, 20, 21, 22, 23, 24, 25, 27, 30, 32 mm | | |
| TORX® sockets 1/2"DR, 5 pcs | | E10, E12, E14, E16, E20 | | |
| Spark plug sockets 1/2"DR, 2 pcs | | 16, 21 mm | | |
| Ratchet handle 1/2"DR | | 250 mm, 48 teeth | | |
| Flexible handle 1/2"DR | | 375 mm | | |
| L-handle 1/2"DR | | 250 mm | | |
| Extension 1/2"DR, 2 pcs | | 75, 250 mm | | |
| Universal joint 1/2"DR | | 70 mm | | |
| 3-way adapter 1/2"DR | | | | |
| Combination wrenches, 17 pcs | | 6, 7, 8, 9, 10, 11, 12, 13, 14, 15, 16, 17, 18, 19, 21, 22, 24 mm | | |
| Flare nut wrench, 5 pcs | | 8x10, 10x12, 11x13, 12x14, 17x19 mm | | |
| Hex keys, 10 pcs | | 2.5, 3, 4, 5, 6, 7, 8, 10, 12, 14 mm | | |
| Screwdriver, 6 pcs | | (PH) 2x38 mm, 2x100 mm, 2x100 mm (impact); (SL) 6x38 mm, 6x150 mm, 6x150 mm (impact) | | |
| Hammer | | 0,3 kg | | |
| Pliers | | 180 mm | | |
| Clamps | | 250 mm | | |

Plastic cases



| Code | Item No. | Name |
|-------|------------|--------------------------|
| 52491 | UTS0038BMC | Plastic case for UTS0038 |
| 52492 | UTS0056BMC | Plastic case for UTS0056 |
| 52493 | UTS0057BMC | Plastic case for UTS0057 |
| 52494 | UTS0072BMC | Plastic case for UTS0072 |
| 52495 | UTS0082BMC | Plastic case for UTS0082 |
| 52496 | UTS0094BMC | Plastic case for UTS0094 |
| 52497 | UTS0108BMC | Plastic case for UTS0108 |
| 52498 | UTS0142BMC | Plastic case for UTS0142 |

Locker for plastic case Thorvik



| Code | Item No. | Name |
|-------|----------|---------------------------------|
| 52499 | UTS001 | Locker for plastic case THORVIK |









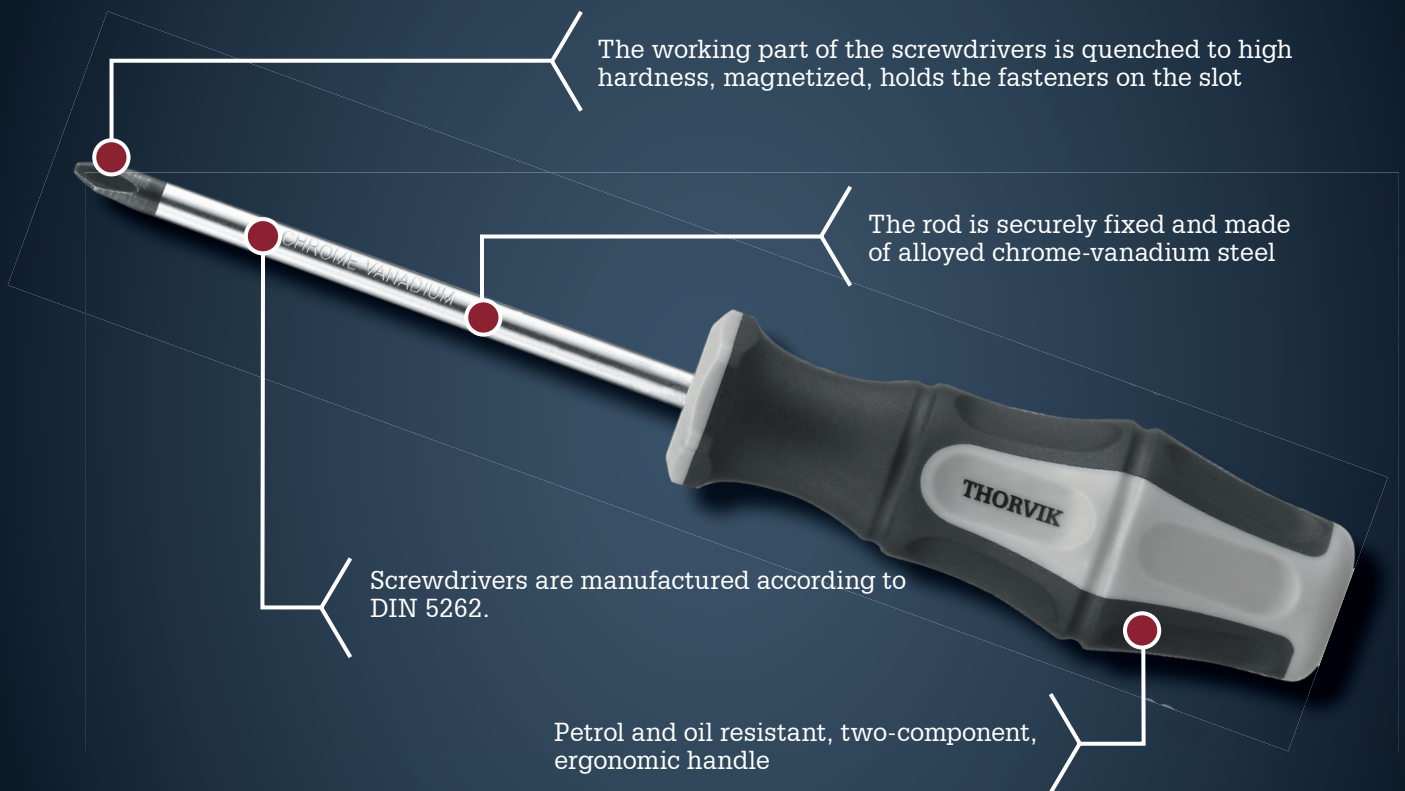



Screwdrivers

THORVIK® screwdrivers are manufactured in accordance with the requirements of DIN 5262 standard. Products are completed with high-quality rods made of chrome-vanadium steel. Magnetized working edge of the screwdrivers are able to hold the fasteners, which very often helps in hard working areas. Ergonomic two-component handles are comfortable. We offer several types of THORVIK® screwdrivers that are used to work with threaded fasteners with internal working profiles: Slot, Phillips®, Pozidriv®,

By design, the screwdrivers can be divided into tools:

1. With concealed installation of the rod in the handle.
2. Screwdrivers with go-thru installation of the rod, which having a steel back plate and a sixsided power amplifier.
3. Insulated screwdrivers.



| | | | | | |
|---|------------|---|-------------------------|---|---|
|  | SL Slotted |  | TORX® tamperproof |  | Complies with the law on safety of equipment and products |
|  | PHILLIPS® |  | Chrome-vanadium steel |  | IEC (IEC) 60900 insulation is applicable up to 1000 V |
|  | POZIDRIV® |  | Magnetized |  | According to DIN standart |
|  | HEX |  | Impact tools | | |
|  | TORX® |  | Tested according to VDE | | |

| | | | | | |
|---|--------------------|---|--|---|---|
|  | Weight of one item |  | Quantity in the package / shipping box |  | Packing weight (gross) / shipping box (gross) |
|---|--------------------|---|--|---|---|

SCREWDRIVERS AND SETS OF THEM

Slotted screwdrivers

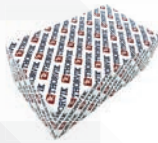
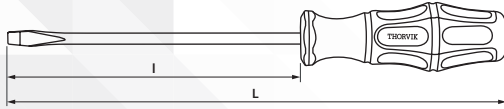

| Code | Item No. | mm | mm | l, mm | L, mm | kg | pcs | kg |
|-------|----------|----|-----|-------|-------|------|--------|----|
| 52130 | SDL3075 | 3 | 0.5 | 75 | 157 | 0,03 | 12/240 | 8 |
| 52131 | SDL3100 | 3 | 0.5 | 100 | 182 | 0,03 | 12/240 | 9 |
| 52132 | SDL3150 | 3 | 0.5 | 150 | 232 | 0,04 | 12/240 | 9 |
| 52133 | SDL4100 | 4 | 0.8 | 100 | 182 | 0,04 | 12/240 | 10 |
| 52144 | SDL5038 | 5 | 1.2 | 38 | 98 | 0,04 | 12/240 | 12 |
| 52134 | SDL5075 | 5 | 1.0 | 75 | 172 | 0,06 | 12/240 | 15 |
| 52135 | SDL5100 | 5 | 1.0 | 100 | 197 | 0,06 | 12/240 | 16 |
| 52136 | SDL5125 | 5 | 1.0 | 125 | 222 | 0,07 | 12/240 | 17 |
| 52137 | SDL5150 | 5 | 1.0 | 150 | 247 | 0,07 | 12/240 | 17 |
| 52138 | SDL6100 | 6 | 1.2 | 100 | 206 | 0,09 | 12/120 | 11 |
| 52139 | SDL6125 | 6 | 1.2 | 125 | 231 | 0,09 | 12/120 | 12 |
| 52140 | SDL6150 | 6 | 1.2 | 150 | 256 | 0,10 | 12/120 | 13 |
| 52141 | SDL8200 | 6 | 1.2 | 200 | 306 | 0,11 | 12/96 | 11 |
| 52142 | SDL8150 | 8 | 1.6 | 150 | 264 | 0,14 | 6/96 | 15 |
| 52143 | SDL8200 | 8 | 1.6 | 200 | 314 | 0,16 | 6/96 | 17 |

Go-Thru impact screwdriver

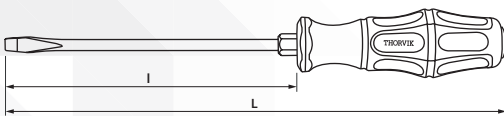

| Code | Item No. | mm | mm | l, mm | L, mm | mm | kg | pcs | kg |
|-------|----------|----|-----|-------|-------|----|------|--------|----|
| 52163 | SDLG575 | 5 | 1.0 | 75 | 172 | 8 | 0,08 | 12/240 | 23 |
| 52164 | SDLG610 | 6 | 1.2 | 100 | 206 | 10 | 0,11 | 12/120 | 15 |
| 52165 | SDLG615 | 6 | 1.2 | 150 | 256 | 10 | 0,12 | 12/120 | 17 |
| 52166 | SDLG815 | 8 | 1.6 | 150 | 264 | 12 | 0,17 | 6/96 | 20 |
| 52167 | SDLG820 | 8 | 1.6 | 200 | 314 | 12 | 0,19 | 6/96 | 22 |

PHILLIPS® screwdriver

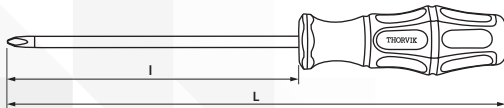

| Code | Item No. | | l, mm | L, mm | kg | pcs | kg |
|-------|----------|-----|-------|-------|------|--------|----|
| 52145 | SDP0075 | PH0 | 75 | 157 | 0,03 | 12/240 | 8 |
| 52146 | SDP0100 | PH0 | 100 | 182 | 0,03 | 12/240 | 9 |
| 52147 | SDP0150 | PH0 | 150 | 232 | 0,04 | 12/240 | 9 |
| 52148 | SDP1075 | PH1 | 75 | 172 | 0,06 | 12/240 | 15 |
| 52149 | SDP1100 | PH1 | 100 | 197 | 0,06 | 12/240 | 16 |
| 52150 | SDP1125 | PH1 | 125 | 222 | 0,07 | 12/240 | 17 |
| 52151 | SDP1150 | PH1 | 150 | 247 | 0,07 | 12/240 | 17 |
| 52158 | SDP2038 | PH2 | 38 | 98 | 0,04 | 12/240 | 12 |
| 52152 | SDP2100 | PH2 | 100 | 206 | 0,09 | 12/120 | 11 |
| 52153 | SDP2125 | PH2 | 125 | 231 | 0,09 | 12/120 | 12 |
| 52154 | SDP2150 | PH2 | 150 | 256 | 0,10 | 12/120 | 13 |
| 52155 | SDP2200 | PH2 | 200 | 306 | 0,11 | 12/120 | 14 |
| 52156 | SDP3150 | PH3 | 150 | 264 | 0,14 | 6/96 | 15 |
| 52157 | SDP3200 | PH3 | 200 | 314 | 0,16 | 6/96 | 17 |

PHILLIPS® Go-Thru impact Screwdriver

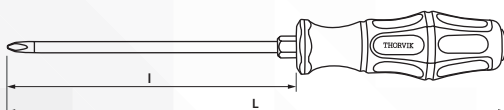

| Code | Item No. | | l, mm | L, mm | mm | kg | pcs | kg |
|-------|----------|-----|-------|-------|----|------|--------|----|
| 52168 | SDPG175 | PH1 | 75 | 172 | 8 | 0,08 | 12/240 | 23 |
| 52169 | SDPG210 | PH2 | 100 | 206 | 10 | 0,11 | 12/120 | 16 |
| 52170 | SDPG215 | PH2 | 150 | 256 | 10 | 0,12 | 12/120 | 17 |
| 52171 | SDPG220 | PH2 | 200 | 306 | 10 | 0,13 | 12/120 | 18 |

Screwdriver sets

Screwdriver set, 6 pcs.



| Code | Item No. | kg | pcs | kg |
|--|----------|------|-----|------|
| 52292 | SDS06CP | 0,62 | 20 | 13,5 |
| Content: SL5x75 mm, SL6x100 mm, SL8x150 mm, PH0x75 mm, PH1x75 mm, PH2x100 mm | | | | |

Screwdriver set, 7 pcs.



| Code | Item No. | kg | pcs | kg |
|---|----------|------|-----|-----|
| 52293 | SDS07CO | 0,62 | 12 | 8,4 |
| Content: SL3x75 mm, SL5.5x100 mm, SL6.5x125 mm, SL8x150 mm, PH0x75 mm, PH1x100 mm, PH2x125 mm | | | | |

Screwdriver set, 6 pcs. on a plastic holder



| Code | Item No. | kg | pcs | kg |
|---|----------|------|-----|------|
| 52290 | SDS06BC | 0,53 | 24 | 13,7 |
| Content: SL5x75 mm, SL6x38 mm, SL6x100 mm, PH1x75 mm, PH2x38 mm, PH2x100 mm | | | | |

Screwdriver set, 6 pcs. on an installable plastic holder



| Code | Item No. | kg | pcs | kg |
|---|----------|------|-----|------|
| 52291 | SDS06BH | 0,55 | 24 | 14,1 |
| Content: SL3x75 mm, SL5x100 mm, SL6x125 mm, PH0x75 mm, PH1x100 mm, PH2x125 mm | | | | |

Go-thru impact screwdriver set, 7 pcs.



| Code | Item No. | kg | pcs | kg |
|---|----------|------|-----|------|
| 52288 | SDGS7CP | 0,79 | 12 | 10,6 |
| Content: SL4x100 mm, SL5.5x100 mm, SL6.5x125 mm, SL8x150 mm, PH0x60 mm, PH1x80 mm, PH2x100 mm | | | | |

Pozidriv® screwdrivers

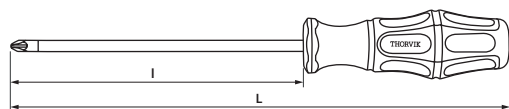

| Code | Item No. | Bit | l, mm | L, mm | kg | pcs | kg |
|-------|----------|-----|-------|-------|------|--------|----|
| 52159 | SDZ0075 | PZ0 | 75 | 157 | 0,03 | 12/240 | 8 |
| 52160 | SDZ1100 | PZ1 | 100 | 197 | 0,06 | 12/240 | 16 |
| 52161 | SDZ2100 | PZ2 | 100 | 206 | 0,09 | 12/120 | 11 |
| 52162 | SDZ3150 | PZ3 | 150 | 264 | 0,14 | 6/96 | 15 |

INSULATED SCREWDRIVERS AND SETS OF THEM

Insulated slotted screwdriver

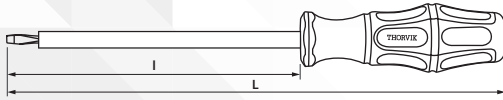

| Code | Item No. | mm | mm | l, mm | L, mm | kg | pcs | kg |
|-------|----------|-----|-----|-------|-------|------|--------|----|
| 52172 | SDLI275 | 2,5 | 0,4 | 75 | 165 | 0,05 | 12/240 | 13 |
| 52173 | SDLI410 | 4 | 0,8 | 100 | 188 | 0,06 | 12/240 | 15 |
| 52174 | SDLI512 | 5,5 | 1,0 | 125 | 225 | 0,08 | 12/240 | 19 |
| 52175 | SDLI615 | 6,5 | 1,2 | 150 | 260 | 0,08 | 12/120 | 11 |
| 52176 | SDLI817 | 8 | 1,6 | 175 | 295 | 0,09 | 6/96 | 9 |

Insulated PHILLIPS® screwdriver



| Code | Item No. | | l, mm | L, mm | kg | pcs | kg |
|-------|----------|-----|-------|-------|------|--------|----|
| 52177 | SDPI060 | PH0 | 60 | 148 | 0,05 | 12/240 | 13 |
| 52178 | SDPI180 | PH1 | 80 | 180 | 0,06 | 12/240 | 15 |
| 52179 | SDPI210 | PH2 | 100 | 210 | 0,07 | 12/120 | 10 |
| 52180 | SDPI315 | PH3 | 150 | 270 | 0,09 | 6/96 | 9 |

Insulated screwdriver set

6 pcs



| Code | Item No. | kg | pcs | kg |
|-------|----------|------|-----|------|
| 52289 | SDIS6CP | 0,52 | 24 | 13,6 |

Content: SL4x100 mm, SL5.5x125 mm, PH1x80 mm, PH2x100 mm, PH3x150 mm, Electric tester

POCKET SCREWDRIVER 4 IN 1

Pocket screwdriver 4 in 1

4 pcs



| Code | Item No. | kg | pcs | kg |
|-------|----------|-------|-----|------|
| 52287 | PPSDS41 | 0,035 | 288 | 11,1 |

Content: Case with two protective caps, double-sided rods, 2 pcs. PH0/SL3, PH1/SL4

HEX KEYS AND SETS OF THEM

Hex keys short

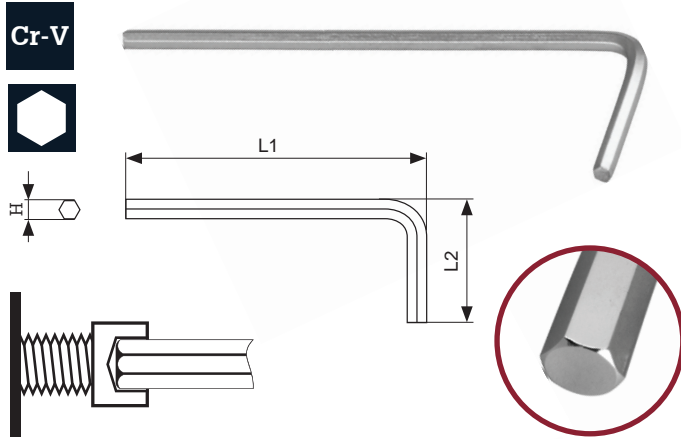

| Code | Item No. | L1, mm | L2, mm | H | KG |
|-------|----------|--------|--------|------|--------|
| 53023 | HKS15 | 46,5 | 15,5 | H1,5 | 0,001 |
| 53024 | HKS20 | 52 | 18 | H2 | 0,0018 |
| 53025 | HKS25 | 58,5 | 20,5 | H2,5 | 0,003 |
| 53026 | HKS30 | 66 | 23 | H3 | 0,005 |
| 53027 | HKS40 | 74 | 28 | H4 | 0,01 |
| 53028 | HKS50 | 85 | 33 | H5 | 0,018 |
| 53029 | HKS60 | 96 | 38 | H6 | 0,029 |
| 53030 | HKS70 | 102 | 41 | H7 | 0,043 |
| 53031 | HKS80 | 108 | 44 | H8 | 0,061 |
| 53032 | HKS100 | 122 | 50 | H10 | 0,107 |

Hex keys

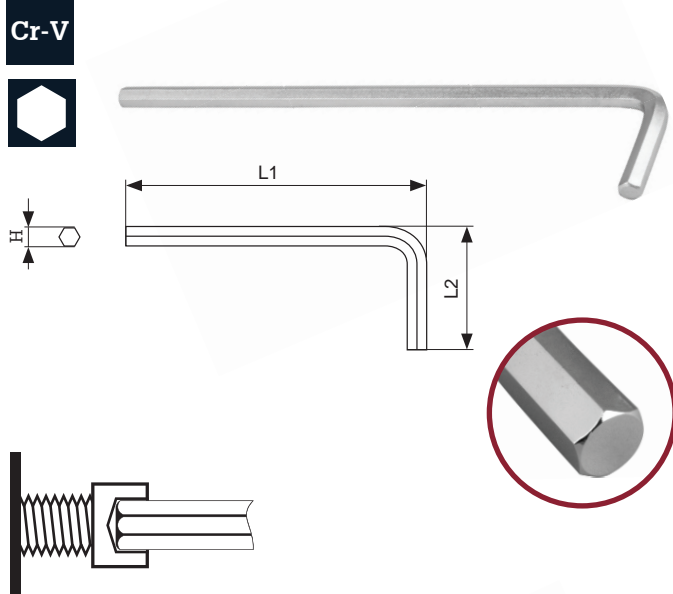

| Code | Item No. | L1, mm | L2, mm | H | KG |
|-------|----------|--------|--------|------|-------|
| 53035 | HK15 | 69,5 | 15,5 | H1,5 | 0,002 |
| 53036 | HK20 | 77 | 18 | H2 | 0,004 |
| 53037 | HK25 | 86,5 | 20,5 | H2,5 | 0,005 |
| 53038 | HK30 | 98 | 23 | H3 | 0,006 |
| 53039 | HK40 | 109 | 28 | H4 | 0,015 |
| 53040 | HK50 | 125 | 33 | H5 | 0,025 |
| 53041 | HK60 | 141 | 38 | H6 | 0,040 |
| 53042 | HK70 | 149 | 41 | H7 | 0,06 |
| 53043 | HK80 | 158 | 44 | H8 | 0,080 |
| 53044 | HK90 | 167 | 47 | H9 | 0,11 |
| 53045 | HK100 | 178 | 50 | H10 | 0,140 |
| 53046 | HK120 | 194 | 57 | H12 | 0,245 |
| 53047 | HK140 | 214 | 69 | H14 | 0,375 |
| 53048 | HK170 | 249 | 77 | H17 | 0,615 |
| 53049 | HK190 | 295 | 89 | H19 | 0,855 |
| 53050 | HK220 | 322 | 102 | H22 | 1,350 |

Hex keys long

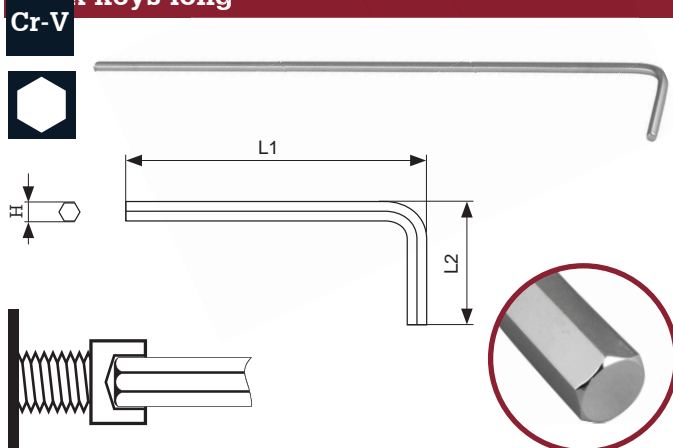

| Code | Item No. | L1, mm | L2, mm | H | KG |
|-------|----------|--------|--------|------|-------|
| 53053 | HKL15 | 91,5 | 15,5 | H1,5 | 0,002 |
| 53054 | HKL20 | 102 | 18 | H2 | 0,004 |
| 53055 | HKL25 | 114,5 | 20,5 | H2,5 | 0,006 |
| 53056 | HKL30 | 129 | 23 | H3 | 0,008 |
| 53057 | HKL40 | 144 | 28 | H4 | 0,018 |
| 53058 | HKL50 | 163 | 33 | H5 | 0,032 |
| 53059 | HKL60 | 184 | 38 | H6 | 0,052 |
| 53060 | HKL70 | 194 | 41 | H7 | 0,077 |
| 53061 | HKL80 | 206 | 44 | H8 | 0,102 |
| 53062 | HKL100 | 232 | 50 | H10 | 0,172 |



Hex keys set

Hex keys set short, H1.5-H10

9 pcs.



Cr-V

| Code | Item No. | KG | pcs. | KG |
|---|----------|------|------|----|
| 53021 | HKS9S | 0,25 | 60 | 16 |
| Content: H1.5, H2, H2.5, H3, H4, H5, H6, H8, H10 mm | | | | |

Hex keys set, H1.5-H10

10 pcs.

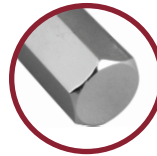

Cr-V

| Code | Item No. | KG | pcs. | KG |
|---|----------|------|------|----|
| 53022 | HKS10S | 0,28 | 60 | 18 |
| Content: H1.5, H2, H2.5, H3, H4, H5, H6, H7, H8, H10 mm | | | | |

Hex keys set, H1.5-H10

9 pcs.



Cr-V

| Code | Item No. | KG | pcs. | KG |
|---|----------|------|------|----|
| 53033 | HK9S | 0,33 | 60 | 21 |
| Content: H1.5, H2, H2.5, H3, H4, H5, H6, H8, H10 mm | | | | |

Hex keys set H1.5-H10

10 pcs.



Cr-V

| Code | Item No. | KG | pcs. | KG |
|---|----------|------|------|----|
| 53034 | HK10S | 0,36 | 60 | 23 |
| Content: H1.5, H2, H2.5, H3, H4, H5, H6, H7, H8, H10 mm | | | | |

Hex keys set long, H1.5-H10

9 pcs.



Cr-V

| Code | Item No. | KG | pcs. | KG |
|---|----------|------|------|----|
| 53051 | HKL9S | 0,45 | 60 | 28 |
| Content: H1.5, H2, H2.5, H3, H4, H5, H6, H8, H10 mm | | | | |

Hex keys set long, H1.5-H10

10 pcs.



Cr-V

| Code | Item No. | KG | pcs. | KG |
|---|----------|-----|------|----|
| 53052 | HKL10S | 0,5 | 60 | 31 |
| Content: H1.5, H2, H2.5, H3, H4, H5, H6, H7, H8, H10 mm | | | | |

Hex keys ball point short

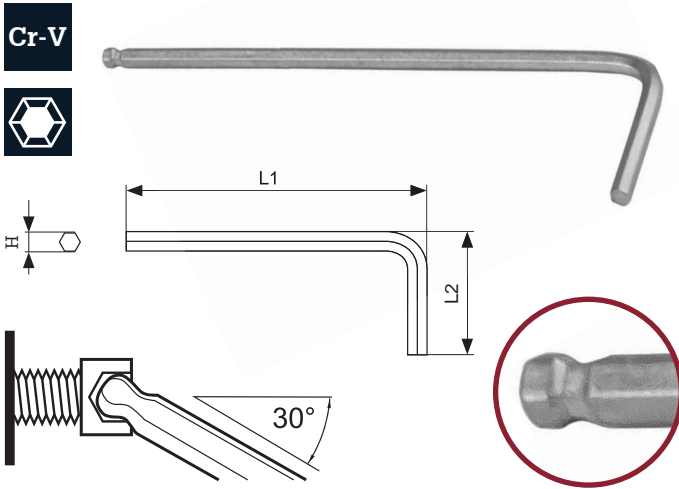

| Code | Item No. | L1, mm | L2, mm | H | KG |
|-------|----------|--------|--------|------|--------|
| 53065 | HKSB15 | 46,5 | 15,5 | H1,5 | 0,001 |
| 53066 | HKSB20 | 52 | 18 | H2 | 0,0018 |
| 53067 | HKSB25 | 58,5 | 20,5 | H2,5 | 0,003 |
| 53068 | HKSB30 | 66 | 23 | H3 | 0,005 |
| 53069 | HKSB40 | 74 | 28 | H4 | 0,01 |
| 53070 | HKSB50 | 85 | 33 | H5 | 0,018 |
| 53071 | HKSB60 | 96 | 38 | H6 | 0,029 |
| 53072 | HKSB70 | 102 | 41 | H7 | 0,043 |
| 53073 | HKSB80 | 108 | 44 | H8 | 0,061 |
| 53074 | HKSB100 | 122 | 50 | H10 | 0,107 |

Hex keys ball point

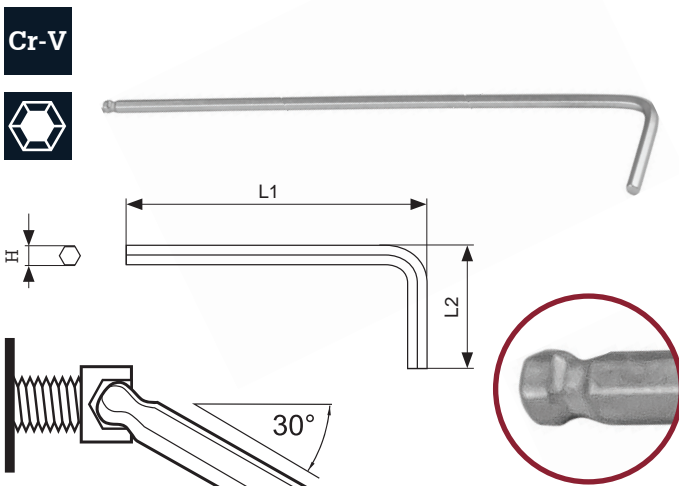

| Code | Item No. | L1, mm | L2, mm | H | KG |
|-------|----------|--------|--------|------|-------|
| 53077 | HKB15 | 69,5 | 15,5 | H1,5 | 0,002 |
| 53078 | HKB20 | 77 | 18 | H2 | 0,004 |
| 53079 | HKB25 | 86,5 | 20,5 | H2,5 | 0,005 |
| 53080 | HKB30 | 98 | 23 | H3 | 0,006 |
| 53081 | HKB40 | 109 | 28 | H4 | 0,015 |
| 53082 | HKB50 | 125 | 33 | H5 | 0,025 |
| 53083 | HKB60 | 141 | 38 | H6 | 0,040 |
| 53084 | HKB70 | 149 | 41 | H7 | 0,06 |
| 53085 | HKB80 | 158 | 44 | H8 | 0,080 |
| 53086 | HKB100 | 178 | 50 | H9 | 0,14 |

Hex keys long ball point

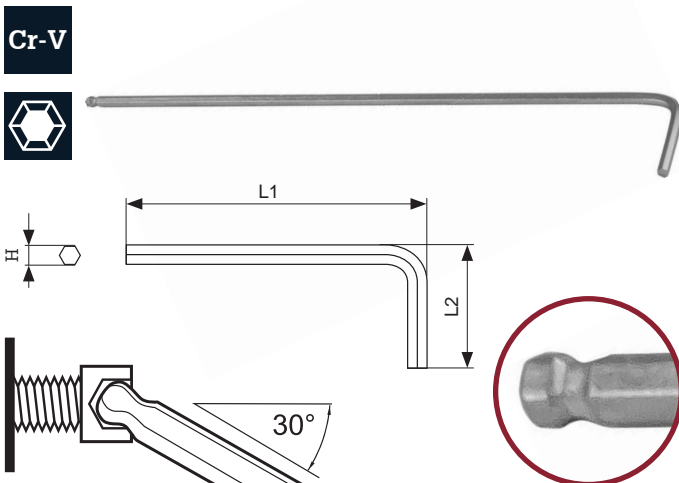

| Code | Item No. | L1, mm | L2, mm | H | KG |
|-------|----------|--------|--------|------|-------|
| 53089 | HKLB15 | 91,5 | 15,5 | H1,5 | 0,002 |
| 53090 | HKLB20 | 102 | 18 | H2 | 0,004 |
| 53091 | HKLB25 | 114,5 | 20,5 | H2,5 | 0,006 |
| 53092 | HKLB30 | 129 | 23 | H3 | 0,008 |
| 53093 | HKLB40 | 144 | 28 | H4 | 0,018 |
| 53094 | HKLB50 | 163 | 33 | H5 | 0,032 |
| 53095 | HKLB60 | 184 | 38 | H6 | 0,052 |
| 53096 | HKLB70 | 194 | 41 | H7 | 0,077 |
| 53097 | HKLB80 | 206 | 44 | H8 | 0,102 |
| 53098 | HKLB100 | 232 | 50 | H10 | 0,172 |

Hex keys ball point sets

Hex keys short ball point set, H1.5-H10

9 pcs.



Cr-V

| Code | Item No. | KG | pcs. | KG |
|---|----------|------|------|----|
| 53063 | HKSB9S | 0,25 | 60 | 16 |
| Content: H1.5, H2, H2.5, H3, H4, H5, H6, H8, H10 mm | | | | |

Hex keys short ball point set, H1.5-H10

10 pcs.



Cr-V

| Code | Item No. | KG | pcs. | KG |
|---|----------|------|------|----|
| 53064 | HKSB10S | 0,28 | 60 | 18 |
| Content: H1.5, H2, H2.5, H3, H4, H5, H6, H7, H8, H10 mm | | | | |

Hex keys ball point set, H1.5-H10

9 pcs.

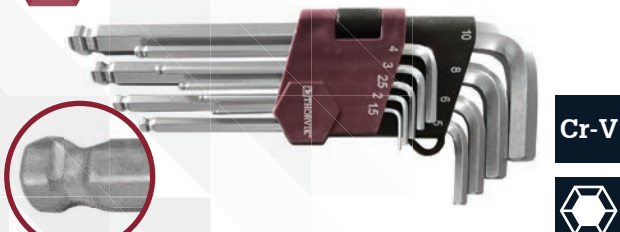

Cr-V

| Code | Item No. | KG | pcs. | KG |
|---|----------|------|------|----|
| 53075 | HKB9S | 0,33 | 60 | 21 |
| Content: H1.5, H2, H2.5, H3, H4, H5, H6, H8, H10 mm | | | | |

Hex keys ball point set, H1.5-H10

10 pcs.



Cr-V

| Code | Item No. | KG | pcs. | KG |
|---|----------|------|------|----|
| 53076 | HKB10S | 0,36 | 60 | 23 |
| Content: H1.5, H2, H2.5, H3, H4, H5, H6, H7, H8, H10 mm | | | | |

Hex keys long ball point set, H1.5-H10

9 pcs.



Cr-V

| Code | Item No. | KG | pcs. | KG |
|---|----------|------|------|----|
| 53087 | HKLB9S | 0,45 | 60 | 28 |
| Content: H1.5, H2, H2.5, H3, H4, H5, H6, H8, H10 mm | | | | |

Hex keys long ball point set, H1.5-H10

10 pcs.



Cr-V

| Code | Item No. | KG | pcs. | KG |
|---|----------|-----|------|----|
| 53088 | HKLB10S | 0,5 | 60 | 31 |
| Content: H1.5, H2, H2.5, H3, H4, H5, H6, H7, H8, H10 mm | | | | |

Hex keys long SAE

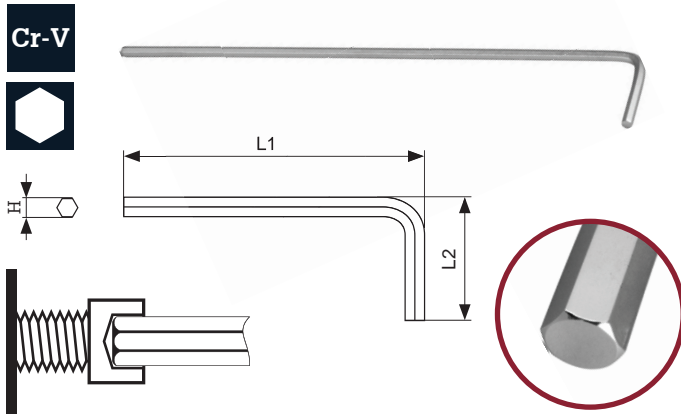

| Code | Item No. | L1, mm | L2, mm | H | KG |
|-------|----------|--------|--------|--------|--------|
| 53100 | HKIL116 | 91,5 | 15,5 | H1/16" | 0,002 |
| 53101 | HKIL564 | 102 | 18 | H5/64" | 0,004 |
| 53102 | HKIL332 | 114,5 | 20,5 | H3/32" | 0,006 |
| 53103 | HKIL18 | 129 | 23 | H1/8" | 0,008 |
| 53104 | HKIL532 | 144 | 28 | H5/32" | 0,018 |
| 53105 | HKIL316 | 152,5 | 30,5 | H3/16" | 0,032 |
| 53106 | HKIL732 | 163,5 | 34,5 | H7/32" | 0,0403 |
| 53107 | HKIL14 | 184 | 38 | H1/4" | 0,0597 |
| 53108 | HKIL516 | 211 | 44 | H5/16" | 0,108 |
| 53109 | HKIL38 | 232 | 50 | H3/8" | 0,17 |

Hex key long SAE set

Hex keys long SAE set, H1/16"-H3/8"



| Code | Item No. | KG | pcs. | KG |
|-------|----------|-----|------|----|
| 53099 | HKIL10S | 0,5 | 60 | 31 |

Content: H1/16", H5/64", H3/32", H1/8", H5/32", H3/16", H7/32", H1/4", H5/16", H3/8"

TORX KEYS AND SETS OF THEM

Torx keys short

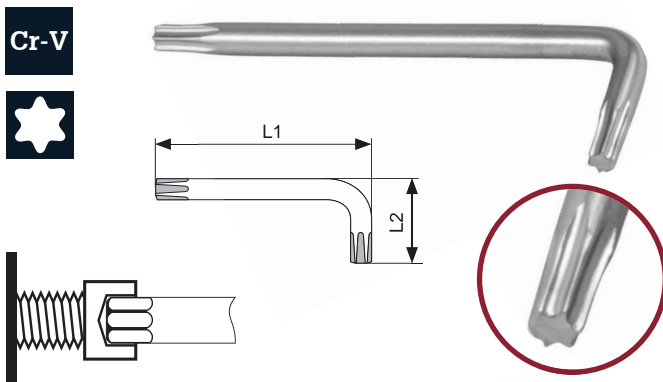

| Code | Item No. | L1, mm | L2, mm | H | KG |
|-------|----------|--------|--------|-----|-------|
| 53111 | TKS10 | 48 | 17 | T10 | 0,004 |
| 53112 | TKS15 | 53,5 | 19,5 | T15 | 0,004 |
| 53113 | TKS20 | 60 | 22 | T20 | 0,008 |
| 53114 | TKS25 | 67,5 | 24,5 | T25 | 0,012 |
| 53115 | TKS27 | 75 | 29 | T27 | 0,016 |
| 53116 | TKS30 | 85,5 | 33,5 | T30 | 0,020 |
| 53117 | TKS40 | 97 | 39 | T40 | 0,038 |
| 53118 | TKS45 | 108 | 44 | T45 | 0,055 |
| 53119 | TKS50 | 121 | 49 | T50 | 0,076 |

Torx keys

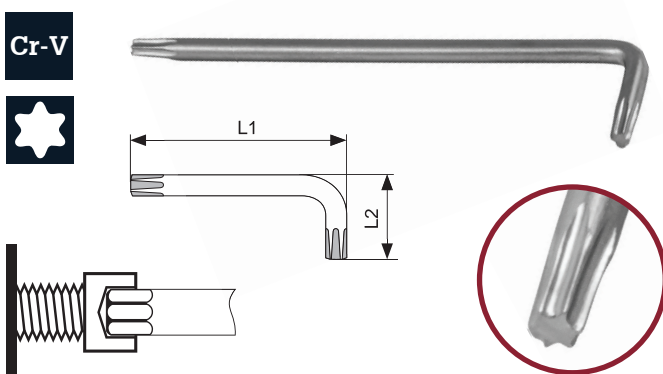

| Code | Item No. | L1, mm | L2, mm | H | KG |
|-------|----------|--------|--------|-----|-------|
| 53121 | TK10 | 71 | 17 | T10 | 0,005 |
| 53122 | TK15 | 78,5 | 19,5 | T15 | 0,006 |
| 53123 | TK20 | 88 | 22 | T20 | 0,010 |
| 53124 | TK25 | 99,5 | 24,5 | T25 | 0,013 |
| 53125 | TK27 | 110 | 29 | T27 | 0,019 |
| 53126 | TK30 | 125,5 | 33,5 | T30 | 0,026 |
| 53127 | TK40 | 142 | 39 | T40 | 0,048 |
| 53128 | TK45 | 158 | 44 | T45 | 0,073 |
| 53129 | TK50 | 177 | 49 | T50 | 0,102 |

Torx keys long

Cr-V

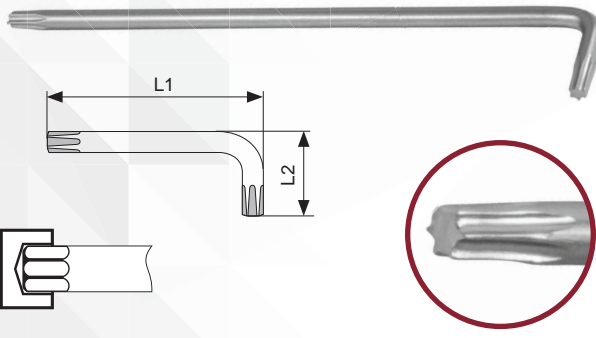

| Code | Item No. | L1, mm | L2, mm | H | KG |
|-------|----------|--------|--------|-----|-------|
| 53131 | TKL10 | 93 | 17 | T10 | 0,006 |
| 53132 | TKL15 | 103,5 | 19,5 | T15 | 0,007 |
| 53133 | TKL20 | 116 | 22 | T20 | 0,013 |
| 53134 | TKL25 | 130,5 | 24,5 | T25 | 0,018 |
| 53135 | TKL27 | 145 | 29 | T27 | 0,025 |
| 53136 | TKL30 | 163,5 | 33,5 | T30 | 0,036 |
| 53137 | TKL40 | 185 | 39 | T40 | 0,065 |
| 53138 | TKL45 | 206 | 44 | T45 | 0,096 |
| 53139 | TKL50 | 231 | 49 | T50 | 0,133 |

Torx keys short sets

Torx keys short set, T10-T50

9 pcs.



Cr-V



| Code | Item No. | KG | pcs. | KG |
|-------|----------|------|------|----|
| 53110 | TKS9S | 0,25 | 60 | 16 |

Content: T10, T15, T20, T25, T27, T30, T40, T45, T50

Torx keys set, T10-T50

10 pcs.



Cr-V



| Code | Item No. | KG | pcs. | KG |
|-------|----------|------|------|----|
| 53120 | TK9S | 0,33 | 60 | 21 |

Content: T10, T15, T20, T25, T27, T30, T40, T45, T50

Torx key long set, T10-T50

9 pcs.

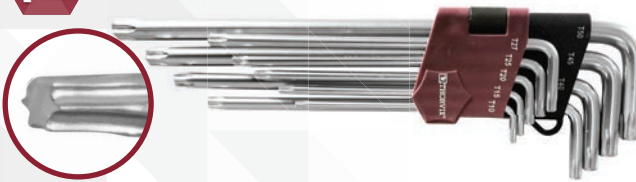

Cr-V



| Code | Item Number | KG | pcs. | KG |
|-------|-------------|------|------|----|
| 53130 | TKL9S | 0,45 | 60 | 28 |

Content: T10, T15, T20, T25, T27, T30, T40, T45, T50

Torx key short tamper proof

Cr-V

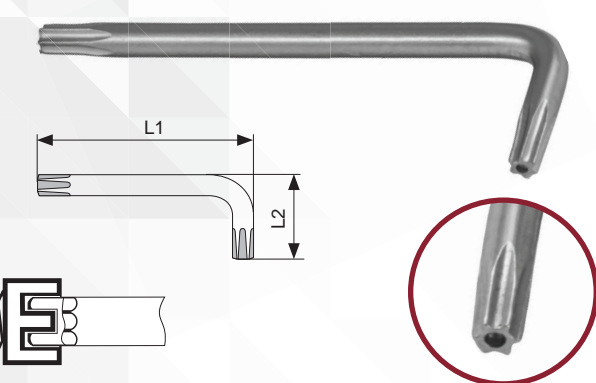

| Code | Item No. | L1, mm | L2, mm | H | KG |
|-------|----------|--------|--------|------|-------|
| 53141 | TTKS10 | 48 | 17 | T10H | 0,004 |
| 53142 | TTKS15 | 53,5 | 19,5 | T15H | 0,004 |
| 53143 | TTKS20 | 60 | 22 | T20H | 0,008 |
| 53144 | TTKS25 | 67,5 | 24,5 | T25H | 0,012 |
| 53145 | TTKS27 | 75 | 29 | T27H | 0,016 |
| 53146 | TTKS30 | 85,5 | 33,5 | T30H | 0,020 |
| 53147 | TTKS40 | 97 | 39 | T40H | 0,038 |
| 53148 | TTKS45 | 108 | 44 | T45H | 0,055 |
| 53149 | TTKS50 | 121 | 49 | T50H | 0,076 |

Torx key short tamper proof

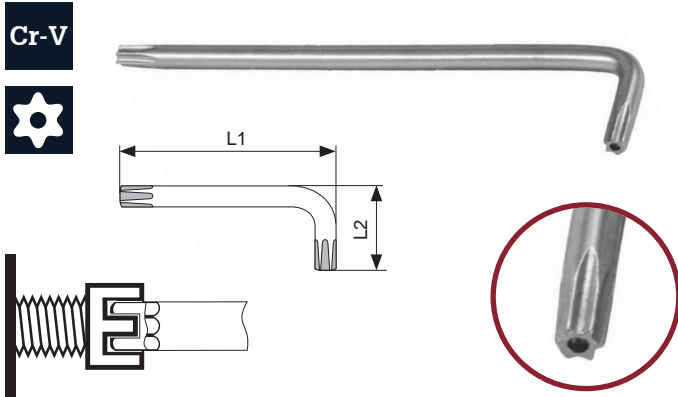

| Code | Item No. | L1, mm | L2, mm | Star | KG |
|-------|----------|--------|--------|------|-------|
| 53151 | TTK10 | 71 | 17 | T10H | 0,005 |
| 53152 | TTK15 | 78,5 | 19,5 | T15H | 0,006 |
| 53153 | TTK20 | 88 | 22 | T20H | 0,010 |
| 53154 | TTK25 | 99,5 | 24,5 | T25H | 0,013 |
| 53155 | TTK27 | 110 | 29 | T27H | 0,019 |
| 53156 | TTK30 | 125,5 | 33,5 | T30H | 0,026 |
| 53157 | TTK40 | 142 | 39 | T40H | 0,048 |
| 53158 | TTK45 | 158 | 44 | T45H | 0,073 |
| 53159 | TTK50 | 177 | 49 | T50H | 0,102 |

Torx key long tamper proof

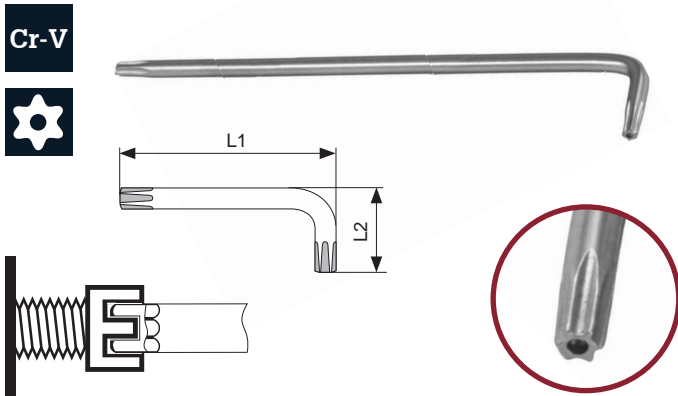

| Code | Item No. | L1, mm | L2, mm | Star | KG |
|-------|----------|--------|--------|------|-------|
| 53161 | TTKL10 | 93 | 17 | T10H | 0,006 |
| 53162 | TTKL15 | 103,5 | 19,5 | T15H | 0,007 |
| 53163 | TTKL20 | 116 | 22 | T20H | 0,013 |
| 53164 | TTKL25 | 130,5 | 24,5 | T25H | 0,018 |
| 53165 | TTKL27 | 145 | 29 | T27H | 0,025 |
| 53166 | TTKL30 | 163,5 | 33,5 | T30H | 0,036 |
| 53167 | TTKL40 | 185 | 39 | T40H | 0,065 |
| 53168 | TTKL45 | 206 | 44 | T45H | 0,096 |
| 53169 | TTKL50 | 231 | 49 | T50H | 0,133 |

Torx keys tamper proof sets

Torx keys short tamper proof set, T10H-T50H



| Code | Item No. | KG | pcs. | KG |
|-------|----------|------|------|----|
| 53140 | TTKS9S | 0,25 | 60 | 16 |

Content: T10H, T15H, T20H, T25H, T27H, T30H, T40H, T45H, T50H

Torx keys tamper proof set, T10H-T50H



| Code | Item No. | KG | pcs. | KG |
|-------|----------|------|------|----|
| 53150 | TTK9S | 0,33 | 60 | 18 |

Content: T10H, T15H, T20H, T25H, T27H, T30H, T40H, T45H, T50H

Torx keys long tamper proof set, T10H-T50H











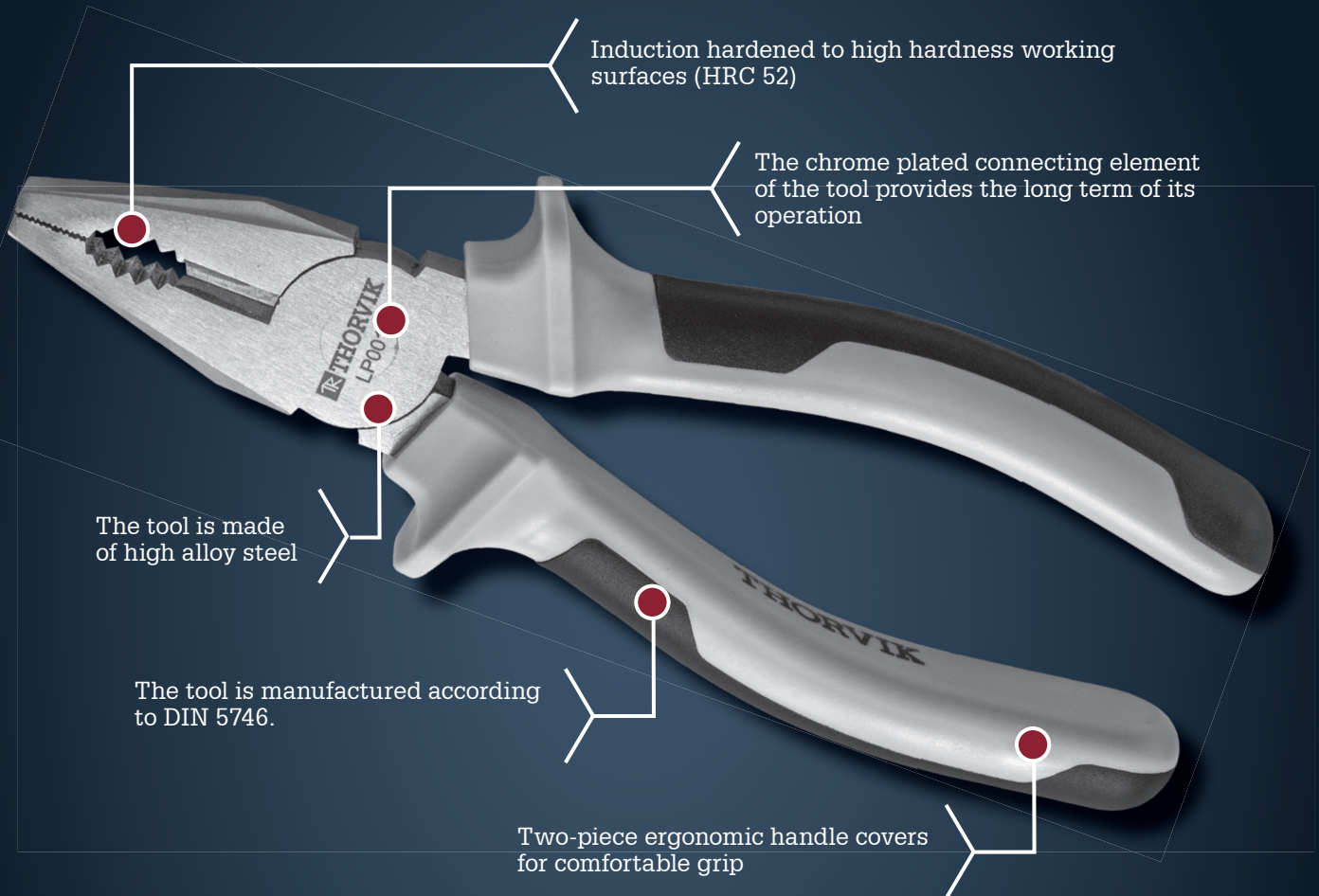





| Code | Item No. | KG | pcs. | KG |
|-------|----------|------|------|----|
| 53160 | TTKL9S | 0,45 | 60 | 21 |

Content: T10H, T15H, T20H, T25H, T27H, T30H, T40H, T45H, T50H

Pliers

A group of hand tools used for fixing objects, cutting, bending materials. THORVIK® pliers are characterized by high quality. Products are made from alloyed steel, have work surfaces quenched to high hardness and a chrome-plated joint element, which ensures their long service life. The tools are equipped with two-component ergonomic handles, meet all modern technical standards.



| | | | | | |
|---|-------------------------|---|-------------------------------|---|---------------------------------------|
|  | Combination pliers |  | Water pump pliers |  | Internal type of locking ring |
|  | Long nose pliers |  | Notches on work surfaces |  | 45° Bend angle of working surfaces |
|  | Diagonal cutting pliers |  | Cutting edge profile |  | 90° Angle of bend of working surfaces |
|  | Nippers |  | External type of locking ring |  | DIN According to DIN standart |
|  | Flat nose |  | Oval-shaped work surfaces | | |



Weight of one item



Quantity in the package / shipping box



Packing weight (gross) / shipping box (gross)

COMBINATION PLIERS

Combination pliers

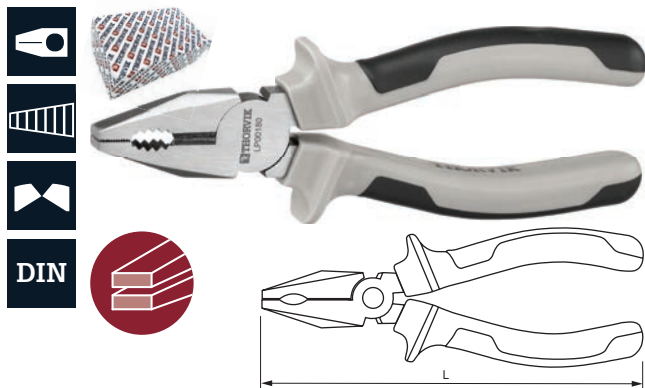

| Code | Item No. | L, mm | kg | pcs | kg |
|-------|----------|-------|------|-----|----|
| 52181 | LP00150 | 150 | 0,23 | 60 | 14 |
| 52182 | LP00180 | 180 | 0,28 | 60 | 17 |
| 52183 | LP00200 | 200 | 0,35 | 60 | 21 |

DIAGONAL CUTTING PLIERS

Diagonal cutting pliers

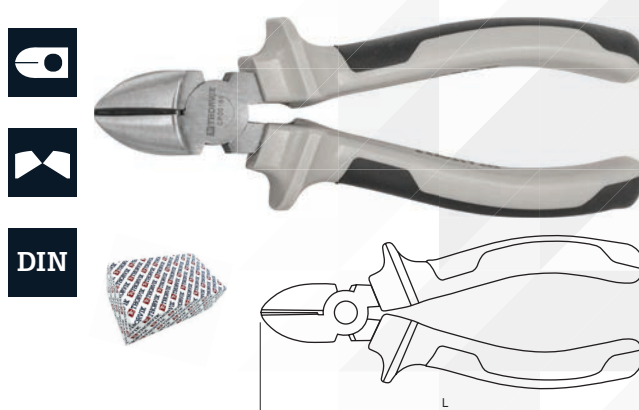

| Code | Item No. | L, mm | kg | pcs | kg |
|-------|----------|-------|------|-----|----|
| 52184 | CP00150 | 150 | 0,22 | 60 | 13 |
| 52185 | CP00180 | 180 | 0,28 | 60 | 17 |

LONG NOSE PLIERS

Straight long nose pliers

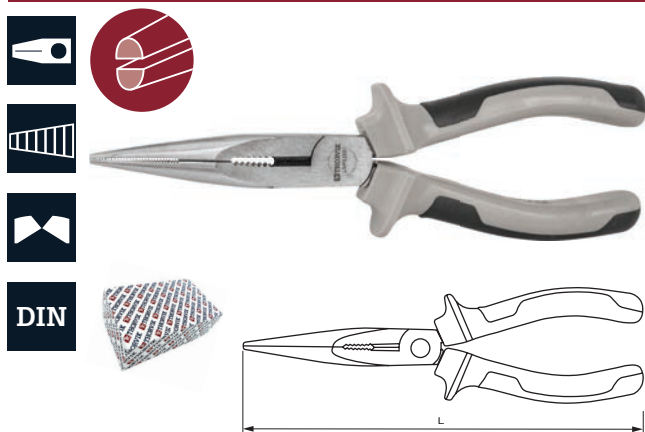

| Code | Item No. | L, mm | kg | pcs | kg |
|-------|----------|-------|------|-----|----|
| 52186 | LNP0180 | 180 | 0,20 | 60 | 12 |
| 52187 | LNP0200 | 200 | 0,22 | 60 | 13 |

Bend long nose pliers

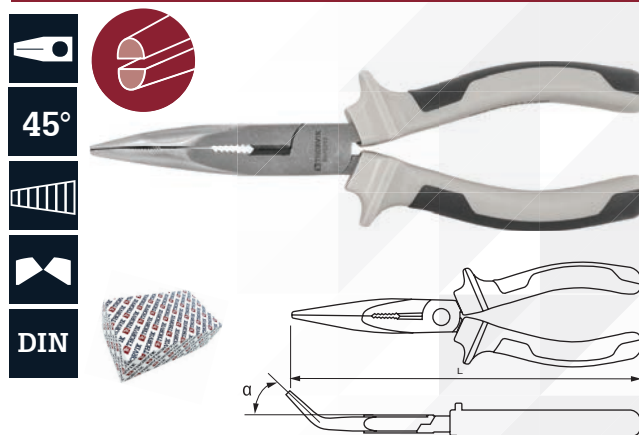

| Code | Item No. | L, mm | α° | kg | pcs | kg |
|-------|----------|-------|----|------|-----|----|
| 52188 | BNP0150 | 150 | 45 | 0,17 | 60 | 10 |
| 52189 | BNP0200 | 200 | 45 | 0,22 | 60 | 13 |

BOX JOINT PLIERS

Box joint pliers



| Code | Item No. | L, mm | T, mm | kg | pcs | kg |
|-------|----------|-------|-------|------|------|---------|
| 52258 | BJP0180 | 180 | 26 | 0,21 | 6/72 | 1,24/17 |
| 52259 | BJP0250 | 250 | 33 | 0,37 | 6/60 | 2,20/24 |
| 52260 | BJP0300 | 300 | 44 | 0,56 | 6/48 | 3,37/29 |
| 52261 | BJP0400 | 400 | 71 | 1,32 | 4/20 | 5,28/28 |

INTERNAL/EXTERNAL PLIERS

Straight nose internal pliers

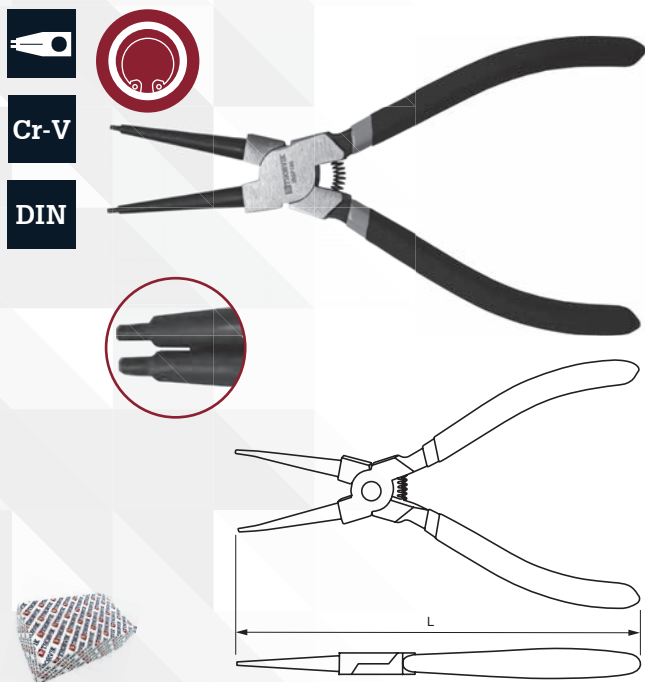

| Code | Item No. | L, mm | Range, mm | kg | pcs | kg |
|-------|----------|-------|-----------|------|-----|----|
| 52192 | IRSP180 | 180 | 12-32 | 0,25 | 60 | 15 |

Bend nose internal pliers

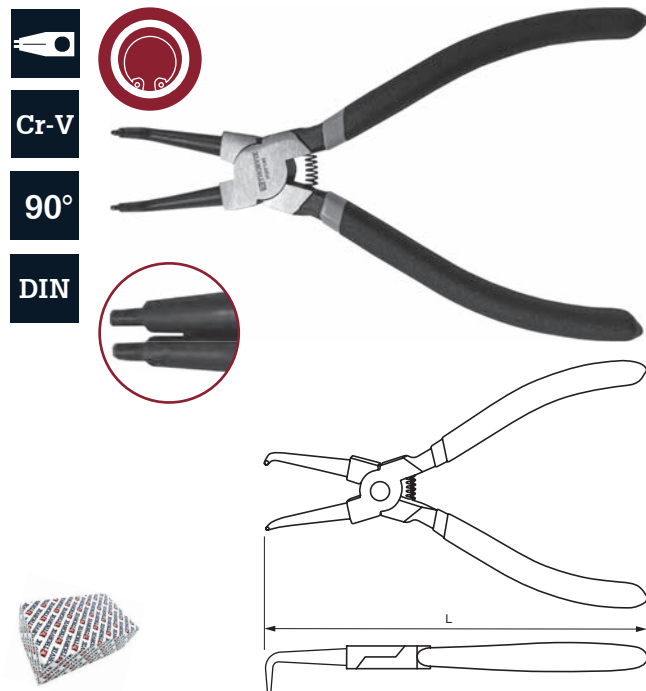

| Code | Item No. | L, mm | Range, mm | kg | pcs | kg |
|-------|----------|-------|-----------|------|-----|----|
| 52190 | IRBP180 | 180 | 12-32 | 0,25 | 60 | 15 |

Straight nose external pliers

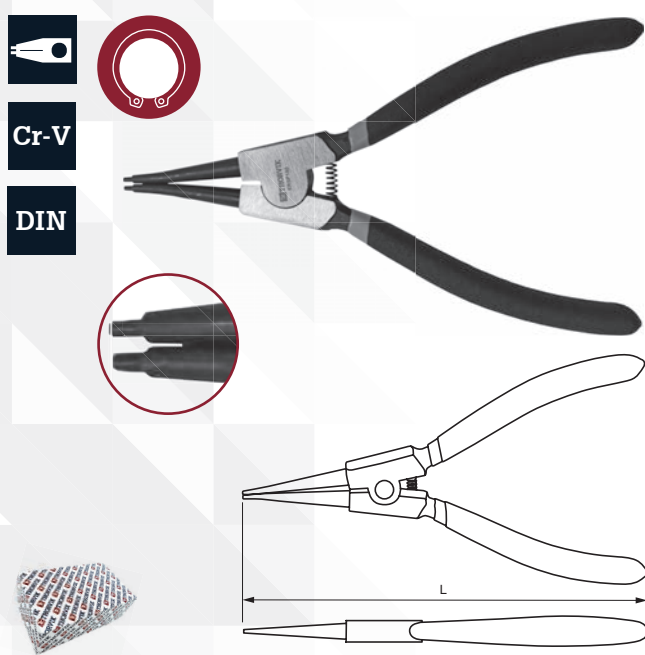

| Code | Item No. | L, mm | Range, mm | kg | pcs | kg |
|-------|----------|-------|-----------|------|-----|----|
| 52193 | ERSP180 | 180 | 12-65 | 0,25 | 60 | 15 |

Bend nose external pliers



| Code | Item No. | L, mm | Range, mm | kg | pcs | kg |
|-------|----------|-------|-----------|------|-----|----|
| 52191 | ERBP180 | 180 | 12-65 | 0,25 | 60 | 15 |

Impactor tool

The line of THORVIK® impact tool contains a range of products that vary in size, application, technology used in the production process. Bench hammers of a «German» type, manufactured according to DIN 1041, weighing from 0.1 to 1 kg, used for general-purpose works and carpentry, weighing 0.45 kg. Sledge hammers weighing from 1 to 8 kg with handles of different length. Products are available with wooden and fiberglass composite handles.

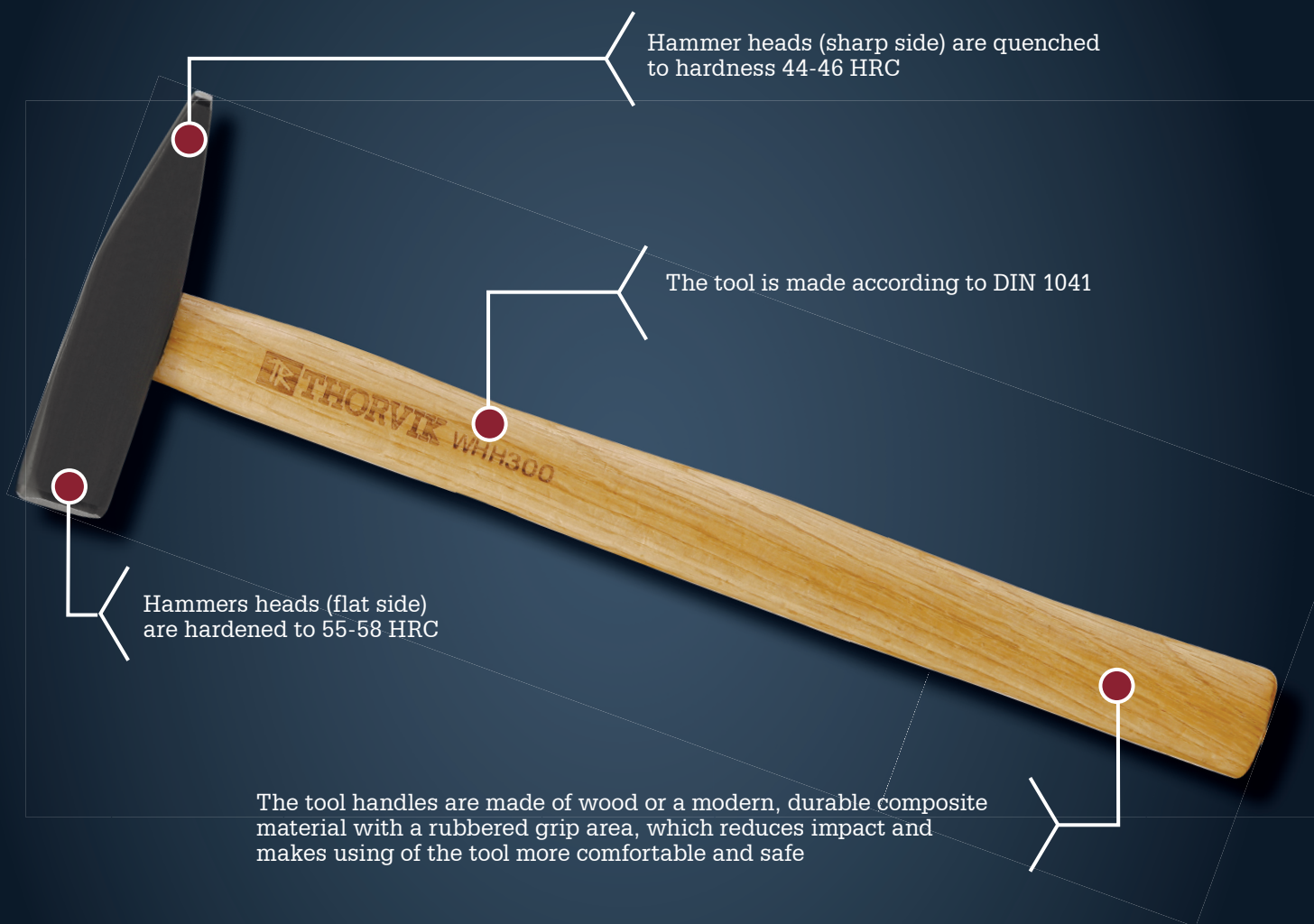

Hammer



Square pin



According to DIN standart



Carpenter hammer



Round pin



Sledgehammer



Weight of one item



Quantity in the package / shipping box



Packing weight (gross) / shipping box (gross)

HAMMERS

Thorvik bench hammers so called "German" type used for general-purpose works. The tool is made according to DIN 1041.

Hammers heads (sharp side) are hardened to 55-58 HRC, hammers heads (flat side) are hardened to 44-46 HRC.

Hammer with wooden handle

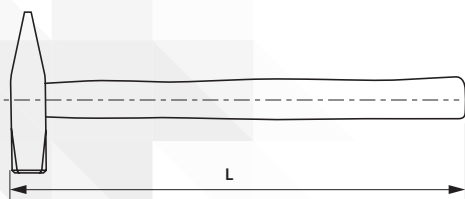

| Code | Item No. | gr. | L, mm | kg | pcs | kg |
|-------|----------|------|-------|------|-------|---------|
| 52242 | WHH100 | 100 | 260 | 0,13 | 6/120 | 0,75/15 |
| 52243 | WHH200 | 200 | 280 | 0,22 | 6/72 | 1,32/16 |
| 52244 | WHH300 | 300 | 300 | 0,33 | 6/60 | 1,98/20 |
| 52245 | WHH500 | 500 | 320 | 0,54 | 6/48 | 3,20/25 |
| 52246 | WHH600 | 600 | 325 | 0,72 | 6/36 | 4,30/26 |
| 52247 | WHH800 | 800 | 350 | 0,91 | 6/24 | 5,46/22 |
| 52241 | WHH001 | 1000 | 360 | 1,16 | 6/24 | 6,99/28 |

Hammer with fiberglass handle

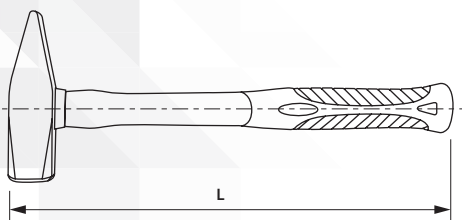

| Code | Item No. | gr. | L, mm | kg | pcs | kg |
|-------|----------|------|-------|------|------|---------|
| 52230 | PHH300 | 300 | 300 | 0,50 | 6/60 | 3,00/30 |
| 52231 | PHH500 | 500 | 320 | 0,77 | 6/48 | 4,62/37 |
| 52232 | PHH800 | 800 | 350 | 1,08 | 6/24 | 6,50/26 |
| 52229 | PHH001 | 1000 | 360 | 1,33 | 6/24 | 8,00/32 |

Carpenter's hammer with fiberglass handle

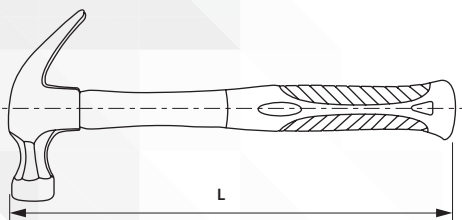

| Code | Item No. | gr. | L, mm | kg | pcs | kg |
|-------|----------|-----|-------|------|------|---------|
| 52228 | PHCH45 | 450 | 325 | 0,75 | 6/36 | 4,50/27 |

Steel hammer with a nail puller and fiberglass handle, covered with a TPR cover.

SLEDGEHAMMER

More powerful than a hammer, impact tool. It is used in cases when the mass of the hammer is not enough. Thorvik offers bench sledgehammers with short handles, which are used for disassembling units, cutting metals, etc., that is, if you need a strong but precise blow, and tools with handles of increased length, for destructive impact. Thorvik sledgehammers are made of steel, supplied with handles of wood or of fiberglass-based composite. Work surfaces hardened to 45 HRC.

Sledge with wooden handle

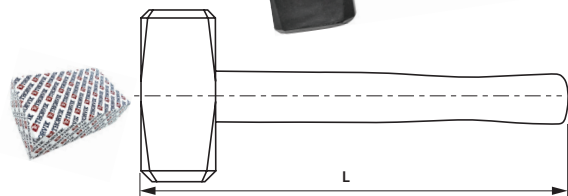

| Code | Item No. | kg | L, mm | kg | pcs | kg |
|-------|----------|------|----------|------|------|----------|
| 52250 | WSH125 | 1,25 | 280 | 1,45 | 6/24 | 8,75/35 |
| 52249 | WSH002 | 2 | 300 | 2,17 | 6/12 | 13,00/26 |
| 52238 | SLSHW3 | 3 | 750/900* | 3,80 | 6 | 23 |
| 52239 | SLSHW5 | 5 | 900 | 6,00 | 4 | 24 |
| 52240 | SLSHW8 | 8 | 900 | 9,00 | 2 | 18 |

* - the length of the handle of the product in different commodity lots may differ

Sledge with fiberglass handle

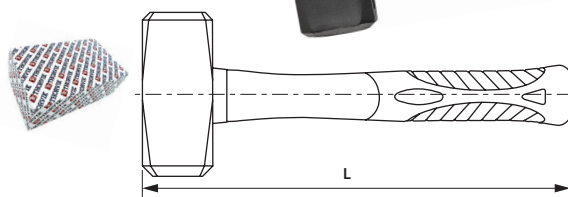

| Code | Item No. | kg | L, mm | kg | pcs | kg |
|-------|----------|------|-------|------|------|----------|
| 52234 | PSH125 | 1,25 | 280 | 1,54 | 6/24 | 9,25/37 |
| 52233 | PSH002 | 2 | 300 | 2,30 | 6/12 | 13,50/27 |
| 52235 | SLSHP3 | 3 | 900 | 4,00 | 6 | 24 |
| 52236 | SLSHP5 | 5 | 900 | 6,00 | 4 | 24 |
| 52237 | SLSHP8 | 8 | 900 | 9,00 | 2 | 18 |

MALLETS

A mallets is an impact tool that is used to transfer the impact to the auxiliary (cutting) tool without damaging of it or for straightening and folding various items made of sheet metal.

Rubber mallet

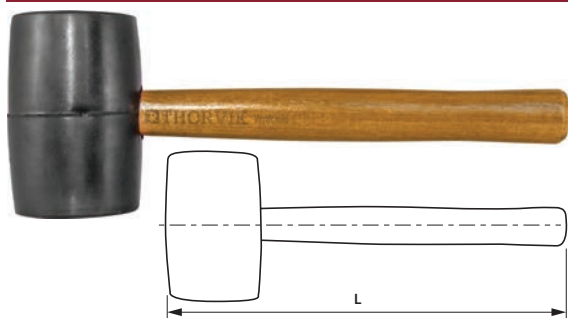

| Code | Item No. | kg | L, mm | kg | pcs | kg |
|-------|----------|-----|-------|------|------|---------|
| 52248 | WHRM90 | 0,9 | 340 | 1,00 | 6/24 | 6,00/24 |

Pneumatic tools

THORVIK® pneumatic tools is the brand, used for mechanization of fitting and assembly work, form a line of the most high-demanded and popular products of this type, including pneumatic impact wrenches of various capacities and sizes of drives from 1/2 "DR to 1" DR, ratchet handles, drills, grinding and angle grinders. The use of THORVIK® pneumatic tools allows you to save manpower and time, plus to it is indispensable in mass production.



1/2" Square drive 1/2" (inch)

3/4" Square drive 3/4" (inch)

1" Square drive 1" (inch)



Weight of one item



Quantity in the package / shipping box



Packing weight (gross) / shipping box (gross)

PNEUMATIC IMPACT WRENCHES

Impact wrench 1/2"DR

Item No.: AIW12717

1/2"



- Full metal body
- Classic model
- High power
- Low weight
- Low vibration level

| Code | Item No. | kg | pcs | kg |
|----------------------------------|---------------|-----|-----|----|
| 52482 | AIW12717 | 2,7 | 8 | 24 |
| Specifications: | | | | |
| Anvil size | 1/2"DR | | | |
| Free speed (RPM) | 7500 RPM | | | |
| Maximum torque | 717 Nm | | | |
| Working torque | 640 Nm | | | |
| Recommended maximum air pressure | 6,3 Bar | | | |
| Average air consumption CFM | 133 l/min | | | |
| Air hose size | 10 mm | | | |
| Air inlet size | 1/4"DR | | | |
| Overall size (lxWxH) | 188x196x69 mm | | | |
| Clutch mechanism | twin hammer | | | |



Spare parts and repair kits are available for this product:

Anvil for AIW12717

Code: 52501; Item No.: RKS112717

Repair kit for AIW12717

Code: 52502; Item No.: RKS212717

Impact wrench 1/2"DR

Item No.: AIW1268

1/2"



- Low weight
- High power
- Composite materials body
- Low vibration level
- Convenient operation

| Code | Item No. | kg | pcs | kg |
|----------------------------------|-------------------|-----|-----|----|
| 52198 | AIW1268 | 2,6 | 6 | 15 |
| Specifications: | | | | |
| Anvil size | 1/2"DR | | | |
| Free speed (RPM) | 7500 RPM | | | |
| Maximum torque | 680 Nm | | | |
| Working torque | 590 Nm | | | |
| Recommended maximum air pressure | 6,3 Bar | | | |
| Average air consumption CFM | 180 l/min | | | |
| Air hose size | 10 mm | | | |
| Air inlet size | 1/4"DR | | | |
| Overall size (lxWxH) | 195,7x187,5x69 mm | | | |
| Clutch mechanism | twin hammer | | | |



Spare parts and repair kits are available for this product:

Anvil for AIW1268

Code: 52208;
Item No.: RKS11268

Set of installation pads for drive of an impact wrench AIW1268

Code: 52209; Item No.: RKS21268

Repair kit for engine

Code: 52210;
Item No.: RKS31268



Гайковерт ударный пневматический, 1/2"DR

Item No.: AIW12122

1/2"



| Code | Item No. | kg | pcs | kg |
|----------------------------------|---------------|-----|-----|----|
| 53009 | AIW12122 | 2,7 | 10 | 31 |
| Характеристики: | | | | |
| Anvil size | 1/2"DR | | | |
| Free speed (RPM) | 8800 об./мин. | | | |
| Maximum torque | 1220 Nm | | | |
| Working torque | 1010 Nm | | | |
| Recommended maximum air pressure | 6,3 Bar | | | |
| Average air consumption CFM | 266 l/min. | | | |
| Air hose size | 10 mm | | | |
| Air inlet size | 1/4"DR | | | |
| Overall size (length) | 193x178x72 mm | | | |
| Clutch mechanism | twin hammer | | | |



Spare parts and repair kits are available for this product:

Anvil for impact wrench AIW12122
Code: 53019; Item No.: RKS112122

Repair kit for AIW12122
Code: 53018; Item No.: RKS212122

Impact wrench 3/4"DR

Item No.: AIW3416

3/4"

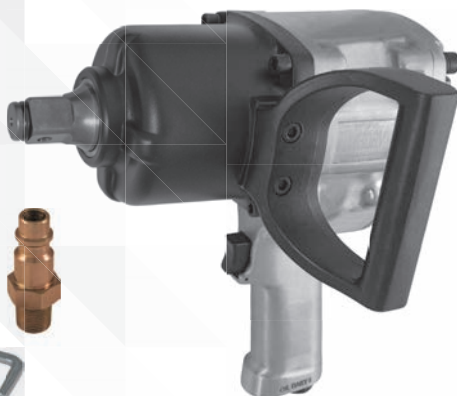

| Code | Item No. | kg | pcs | kg |
|----------------------------------|-------------|-----|-----|----|
| 52749 | AIW3416M | 7,0 | 4 | 30 |
| Specifications: | | | | |
| Anvil size | 3/4"DR | | | |
| Free speed (RPM) | 5000 RPM | | | |
| Maximum torque | 1800 Nm | | | |
| Recommended maximum air pressure | 6,3 Bar | | | |
| Average air consumption CFM | 210 l/min | | | |
| Air hose size | 12 mm | | | |
| Air inlet size | 3/8"DR | | | |
| Overall size (length) | 235 mm | | | |
| Clutch mechanism | twin hammer | | | |



Spare parts and repair kits are available for this product:

Anvil for AIW3416M
Code: 52785; Item No.: RKS23416M

Repair kit for engine AIW3416M
Code: 52782; Item No.: RKS13416M

Impact wrench 1"DR

Item No.: AIWS125

1"



The product is supplied in an individual plastic case with a set of accessories and sockets 1"DR 32 mm and 33 mm.

| Code | Item No. | kg | pcs | kg |
|----------------------------------|--------------|------|-----|------|
| 52751 | AIWS125M | 13,7 | 1 | 17,2 |
| Specifications: | | | | |
| Anvil size | 1"DR | | | |
| Legth | 540 mm | | | |
| Anvil legth | 225 mm | | | |
| Free speed (RPM) | 4000 RPM | | | |
| Maximum torque | 2300 Nm | | | |
| Recommended maximum air pressure | 8-14 Bar | | | |
| Average air consumption CFM | 288 l/min | | | |
| Air hose size | 19 mm | | | |
| Air inlet size | 1/2"DR | | | |
| Clutch mechanism | axles hammer | | | |



Spare parts and repair kits are available for this product:

Anvil for AIWS125
Code: 52784; Item No.: RKS2125M

Repair kit for engine AIWS125M
Code: 52781; Item No.: RKS1125M

Impact wrench 1"DR

Item No.: AIWS124

1"



■ The product is supplied in an individual plastic case with a set of accessories and sockets 1"DR 32 mm and 33 mm.

| Code | Item No. | kg | pcs | kg |
|----------------------------------|--------------|------|-----|------|
| 52750 | AIWS124M | 16,6 | 1 | 20,6 |
| Specifications: | | | | |
| Anvil size | 1"DR | | | |
| Legth | 615 mm | | | |
| Anvil legth | 225 mm | | | |
| Free speed (RPM) | 3200 RPM | | | |
| Maximum torque | 3200 Nm | | | |
| Recommended maximum air pressure | 8-14 Bar | | | |
| Average air consumption CFM | 336 l/min | | | |
| Air hose size | 19 mm | | | |
| Air inlet size | 1/2"DR | | | |
| Clutch mechanism | axles hammer | | | |



Spare parts and repair kits are available for this product:

Anvil for AIWS124

Code: 52783; Item No.: RKS2124M

Repair kit for engine AIWS124M

Code: 52780; Item No.: RKS1124M

AIR RATCHET WRENCH

Air ratchet wrench, 1/2"DR

Item No.: ARW1261

1/2"



| Code | Item No. | kg | pcs | kg |
|----------------------------------|-------------------|------|-----|----|
| 52201 | ARW1261 | 1,19 | 20 | 26 |
| Specifications: | | | | |
| Anvil size | 1/2"DR | | | |
| Free speed (RPM) | 150 RPM | | | |
| Maximum torque | 61 Nm | | | |
| Recommended maximum air pressure | 6,3 Bar | | | |
| Average air consumption CFM | 141 l/min | | | |
| Air hose size | 10 mm | | | |
| Air inlet size | 1/4"DR | | | |
| Overall size (length) | 262 mm | | | |
| Clutch mechanism | ratchet mechanism | | | |



Spare parts and repair kits are available for this product:

Anvil for ARW1261

Code: 52216; Item No.: RKS01261

The rotor blades of the engine for pneumatic ratchet handle ARW1261

Code: 52217; Item No.: RKS01261

Air ratchet wrench, 3/8"DR

Item No.: ARW3827

3/8"



| Code | Item No. | kg | pcs | kg |
|----------------------------------|-------------------|-----|-------|-------|
| 52649 | ARW3827 | 0,6 | 20,00 | 12,42 |
| Specifications: | | | | |
| Anvil size | 3/8"DR | | | |
| Free speed (RPM) | 180 RPM | | | |
| Maximum torque | 27 Nm | | | |
| Recommended maximum air pressure | 6,3 Bar | | | |
| Average air consumption CFM | 113 l/min | | | |
| Air hose size | 10 mm | | | |
| Air inlet size | 1/4"DR | | | |
| Overall size (length) | 183 mm | | | |
| Clutch mechanism | ratchet mechanism | | | |

AIR DRILL

Pneumatic drill with reverse

Item No.: RAD1018



| Code | Item No. | kg | pcs | kg |
|----------------------------------|----------|-----------|-----|----|
| 52202 | RAD1018 | 1,16 | 20 | 26 |
| Specifications: | | | | |
| Chuck size, working range | | 1-10 mm | | |
| Free speed (RPM) | | 1800 RPM | | |
| Recommended maximum air pressure | | 6,3 Bar | | |
| Average air consumption CFM | | 141 l/min | | |
| Air hose size | | 10 mm | | |
| Air inlet size | | 1/4"DR | | |
| Overall size (length) | | 193 mm | | |
| Clutch mechanism | | Planetary | | |



Spare parts and repair kits are available for this product:

The rotor blades of the engine wrench RAD1018

Code: 52218; Item No.: RKS11018

Satellites of a planetary reducer of a drill of RAD1018

Code: 52219; Item No.: RKS21018

Three-jaw chuck, self-locking, with key, for RAD1018

Code: 52220; Item No.: RKS31018

Air straight drill

Item No.: SAD2500

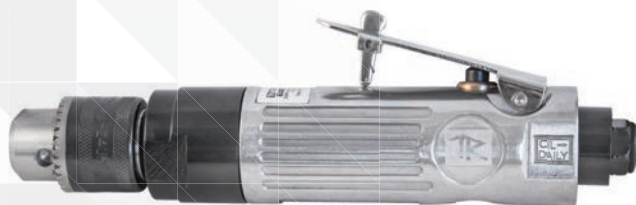

| Code | Item No. | kg | pcs | kg |
|----------------------------------|----------|--------------|-------|-------|
| 52654 | SAD2500 | 1 | 20,00 | 20,49 |
| Specifications: | | | | |
| Chuck size, working range | | 1-10 mm | | |
| Free speed (RPM) | | 2500 RPM | | |
| Recommended maximum air pressure | | 6,3 Bar | | |
| Average air consumption CFM | | 198 l/min | | |
| Air hose size | | 10 mm | | |
| Air inlet size | | 1/4"DR | | |
| Overall size (length) | | 225 mm | | |
| Clutch mechanism | | Planetary | | |
| Exhaust direction | | Rear exhaust | | |

Air angle drill

Item No.: AAD1500



| Code | Item No. | kg | pcs | kg |
|----------------------------------|----------|--------------|-----|-------|
| 52640 | AAAD1500 | 0,72 | 30 | 22,05 |
| Specifications: | | | | |
| Chuck size, working range | | 1-10 mm | | |
| Free speed (RPM) | | 15000 RPM | | |
| Recommended maximum air pressure | | 6,3 Bar | | |
| Average air consumption CFM | | 113 l/min | | |
| Air hose size | | 10 mm | | |
| Air inlet size | | 1/4"DR | | |
| Overall size (length) | | 170 mm | | |
| Clutch mechanism | | Planetary | | |
| Exhaust direction | | Rear exhaust | | |

Also, the range of TM THORVIK has a large selection of drills, which you can find on pages 85-88 of this catalog.

AIR DIE GRINDERS

Air die grinder

Item No.: ADG6022



| Code | Item No. | kg | pcs | kg |
|----------------------------------|----------|---------------|-----|----|
| 52203 | ADG6022 | 0,69 | 30 | 24 |
| Specifications: | | | | |
| Размер цанги | | 6 mm | | |
| Free speed (RPM) | | 22000 RPM | | |
| Recommended maximum air pressure | | 6,3 Bar | | |
| Average air consumption CFM | | 198 l/min | | |
| Air hose size | | 10 mm | | |
| Air inlet size | | 1/4"DR | | |
| Overall size (LxWxH) | | 168x62,8x40,5 | | |



Spare parts and repair kits are available for this product:

The rotor blades of the engine wrench ADG6022

Code: 52221; Item No.: RKS16022

Extension air die grinder

Item No.: EADG6020



| Code | Item No. | kg | pcs | kg |
|----------------------------------|----------|--------------|-------|-------|
| 52652 | EADG6020 | 0,79 | 30,00 | 24,18 |
| Specifications: | | | | |
| Collet size | | 6 mm | | |
| Free speed (RPM) | | 20000 RPM | | |
| Recommended maximum air pressure | | 6,3 Bar | | |
| Average air consumption CFM | | 113 l/min | | |
| Air hose size | | 10 mm | | |
| Air inlet size | | 1/4"DR | | |
| Overall size (length) | | 285 mm | | |
| Exhaust direction | | Rear exhaust | | |

Air angle die grinder

Item No.: AADG6020



| Code | Item No. | kg | pcs | kg |
|----------------------------------|----------|--------------|-------|-------|
| 52641 | AADG6020 | 0,64 | 30,00 | 19,61 |
| Specifications: | | | | |
| Collet size | | 6 mm | | |
| Free speed (RPM) | | 20000 RPM | | |
| Recommended maximum air pressure | | 6,3 Bar | | |
| Average air consumption CFM | | 113 l/min | | |
| Air hose size | | 10 mm | | |
| Air inlet size | | 1/4"DR | | |
| Overall size (length) | | 157 mm | | |
| Exhaust direction | | Rear exhaust | | |

AIR ANGLE GRINDERS

Air angle grinder

Item No.: AAG0510



| Code | Item No. | kg | pcs | kg |
|----------------------------------|----------|-----------|-------|-------|
| 52642 | AAG0510 | 2,12 | 10,00 | 21,94 |
| Specifications: | | | | |
| Grinding wheel diametr, Max | | 125 mm | | |
| Spindle thread | | 22 mm | | |
| Free speed (RPM) | | 10000 RPM | | |
| Recommended maximum air pressure | | 6,3 Bar | | |
| Average air consumption CFM | | 169 l/min | | |
| Air hose size | | 10 mm | | |
| Air inlet size | | 1/4"DR | | |
| Overall size (length) | | 228 mm | | |

Grinding pneumatic orbital machine with dust extraction

Item No.: AOS6105



| Code | Item No. | kg | pcs | kg |
|----------------------------------|----------|-----------|-------|-------|
| 52648 | AOS6105 | 1,5 | 10,00 | 15,92 |
| Specifications: | | | | |
| Disk diametr | | 150 mm | | |
| Free speed (RPM) | | 10500 RPM | | |
| Recommended maximum air pressure | | 6,3 Bar | | |
| Average air consumption CFM | | 84 l/min | | |
| Eccentricity | | 5 mm | | |
| Air hose size | | 10 mm | | |
| Air inlet size | | 1/4"DR | | |
| Overall size (length) | | 214 mm | | |

Also, the assortment of TM Thorvik has a large selection of cutting, flap and grinding discs, which you can find on the page 83 of this catalog.

AIR HAMMERS

Pneumatic hammer with nozzles in a set

Item No.: AHK9150



| Code | Item No. | kg | pcs | kg |
|----------------------------------|----------|----------------|------|-------|
| 52647 | AHK9150 | 2,15 | 8,00 | 17,96 |
| Specifications: | | | | |
| Spindle thread | | 10,2 mm | | |
| Blow per minute | | 4500 | | |
| Recommended maximum air pressure | | 6,3 Bar | | |
| Average air consumption CFM | | 113 l/min | | |
| Air hose size | | 10 mm | | |
| Air inlet size | | 1/4"DR | | |
| Overall size (length) | | 150 mm | | |
| Weight of the air hammer | | 1,45 kg | | |
| Overall size (LxWxH) | | 460x320x290 mm | | |
| Weight of the kit | | 2,05 kg | | |

AIR BLOW GUNS

Air blow gun



- Composite materials
- Ergonomic design

| Code | Item No. | Nose length (mm) | kg | pcs | kg |
|-------|----------|------------------|------|-------|-------|
| 52205 | ABG6510 | 100 | 0,22 | 40,00 | 10 |
| 52643 | ABG6520 | 200 | 0,23 | 40,00 | 10,8 |
| 52644 | ABG6530 | 300 | 0,26 | 40,00 | 12,02 |

Specifications:

| | |
|-----------------------------|-------------------------|
| Working pressure | 2-6 KGc/cm ² |
| Average air consumption CFM | 180 l/min |

Air blow gun with nozzles

Item No.: ABGK5

5 pcs



| Code | Item No. | kg | pcs | kg |
|-------|----------|------|--------|-------|
| 52645 | ABGK5 | 0,16 | 100,00 | 16,71 |

Air blow gun with nozzles

Item No.: ABGK7

7 pcs



| Code | Item No. | kg | pcs | kg |
|-------|----------|------|--------|-------|
| 52646 | ABGK7 | 0,16 | 100,00 | 16,71 |

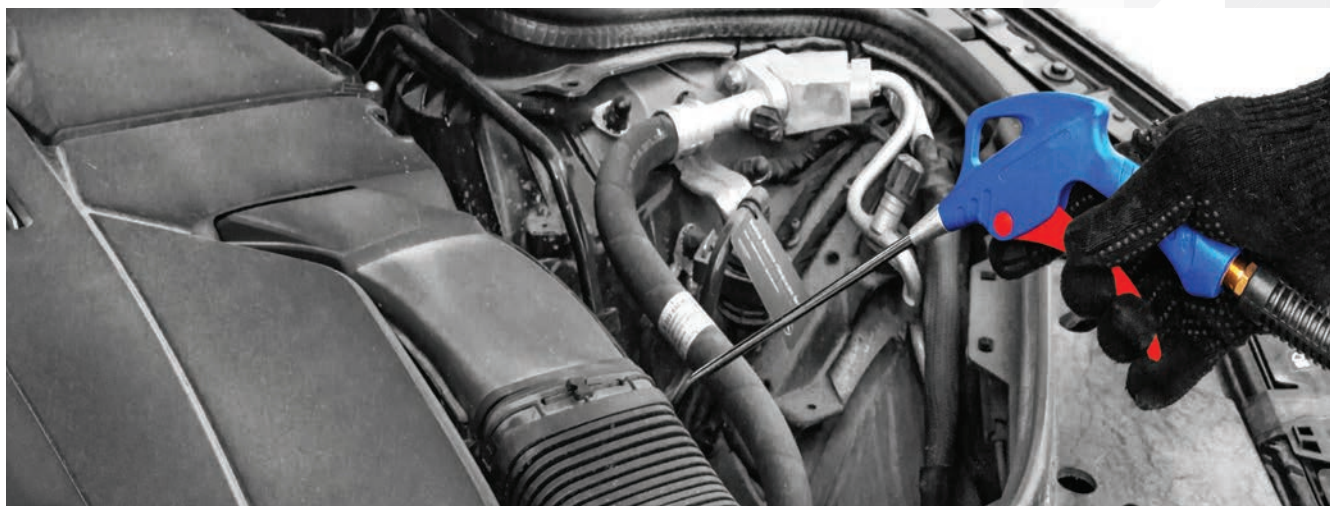

AIR HOSES FOR PNEUMATIC TOOLS

PVC hoses with 1/4" NPT fittings for pneumatic tools



| Code | Item No. | Air inlet size | Iternal diametr, mm | Eternal diametr, mm | Legth (meters) | kg | pcs | kg |
|-------|----------|----------------|---------------------|---------------------|----------------|-----|-----|----|
| 52262 | CAH615 | 1/4" NPT | 6,3 | 12 | 15 | 1,8 | 10 | 20 |
| 52263 | CAH915 | 1/4" NPT | 9,5 | 15,5 | 15 | 3,0 | 6 | 19 |

PVC hoses for pneumatic tools, in coils



| Code | Item No. | Iternal diametr, mm | Eternal diametr, mm | Legth (meters) | kg | pcs | kg |
|-------|----------|---------------------|---------------------|----------------|------|-----|----|
| 52266 | RAH615 | 6,3 | 12 | 15 | 1,5 | 10 | 16 |
| 52265 | RAH605 | 6,3 | 12 | 50 | 5,0 | 4 | 21 |
| 52264 | RAH601 | 6,3 | 12 | 100 | 10,0 | 2 | 21 |
| 52267 | RAH915 | 9,5 | 15,5 | 15 | 2,2 | 6 | 14 |
| 52269 | RAH955 | 9,5 | 15,5 | 50 | 7,5 | 2 | 16 |
| 52268 | RAH951 | 9,5 | 15,5 | 100 | 15,0 | 1 | 16 |

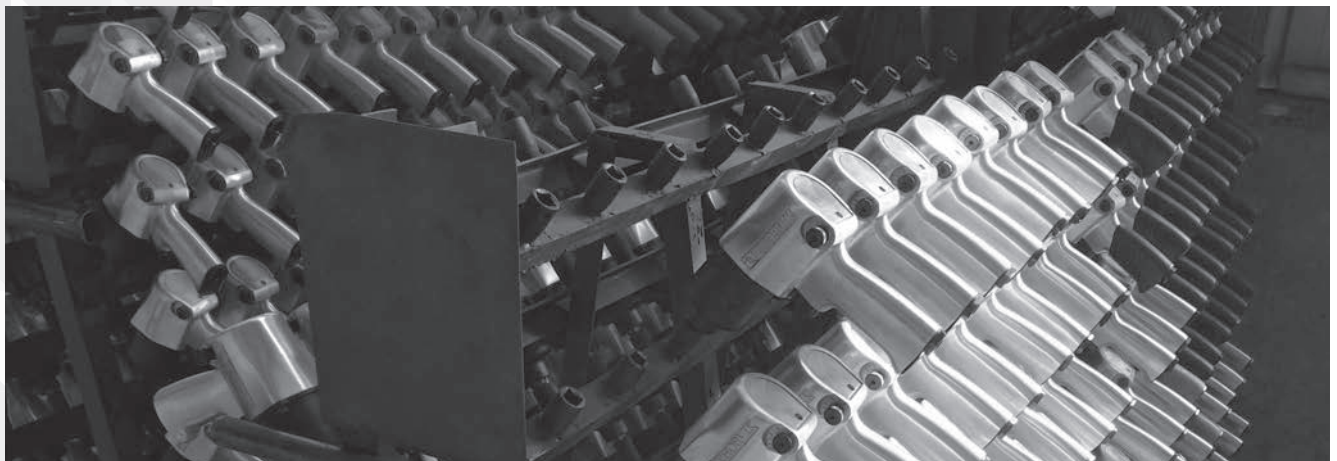

Automotive tools

TM THORVIK® automotive tool designed for maintenance and repair of all types of vehicles. It is used in work with a variety of units and assemblies of motor vehicles and agricultural equipment, including in hard working areas. TM THORVIK® automotive tool allows you to perform maintenance independently, without contacting specialized centers. Many types of repair work on vehicles that previously presented a great deal of complexity and took a lot of time have become more accessible and easier, both for the professional and for the amateur thanks to the TM THORVIK® automotive tool line.



2-Jaws gear puller

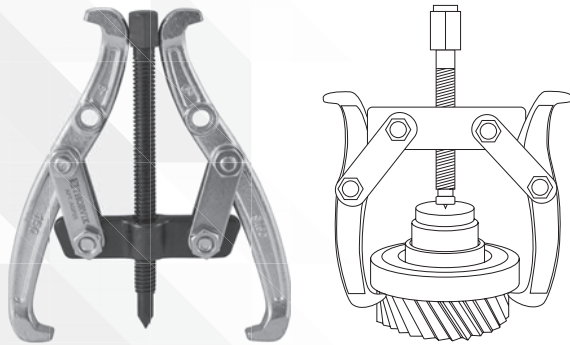

3-Jaws gear puller

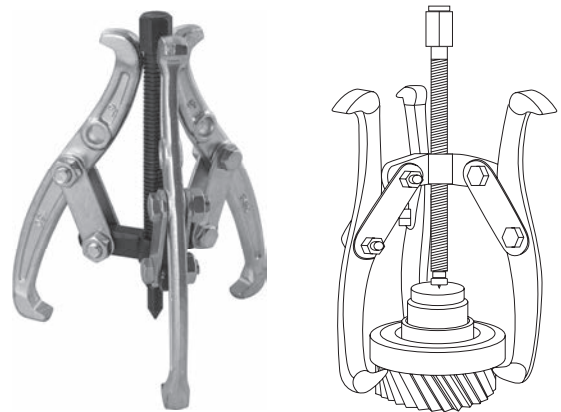

| Code | Item No. | Size, mm | Working range, mm |
|-------|----------|----------|-------------------|
| 52321 | AGP23 | 75 | 40-75 |
| 52322 | AGP24 | 100 | 50-100 |
| 52323 | AGP26 | 150 | 60-150 |
| 52324 | AGP28 | 200 | 80-200 |

| Code | Item No. | Size, mm | Working range, mm |
|-------|----------|----------|-------------------|
| 52325 | AGP33 | 75 | 40-75 |
| 52326 | AGP34 | 100 | 50-100 |
| 52327 | AGP36 | 150 | 60-150 |
| 52328 | AGP38 | 200 | 80-200 |

Multifunction puller with bolt clamps in a set. Range of captures is 30-120 mm, 13 pcs.



| Code | Item No. | Working range, mm |
|--|----------|-------------------|
| 52329 | AHBPS13 | 30-120 |
| Content (13 pcs): | | |
| Traverse large for a range of 30-120 mm; | | |
| Spindle screw, 125 mm; | | |
| Bolts, thread 1/4"x50mm, 3 pcs; | | |
| Bolts, thread 1/4"x75mm, 2 pcs; | | |
| Bolts, thread 5/16"x50mm, 3 pcs; | | |
| Bolts, thread 5/16"x100mm, 2 pcs; | | |
| Support screw; | | |
| Plastic case. | | |

Threading tools.

- Threaded inserts are designed to restore the functionality and original dimensions of a worn or damaged threaded connection.
- THORVIK thread inserts are made of corrosion-resistant rhombic wire in the form of a spring spiral;
- They are used in mechanical engineering, the automotive industry for repairs of cylinder engine heads, gearboxes, plug holes and oil drain nozzles, in the medical industry, energy, in the repair of turbines at power plants, in aviation workshops, in the repair of military equipment, etc.



Threading steps

1. Drilling. Hole preparation.
Drill a hole of the appropriate diameter to remove damaged threads and prepare for threading. Follow the manufacturer's recommendations and the data in DIN8140.

2. Threading.
Thread EG standard with STI specialized tap. Follow the manufacturer's recommendations and the data in DIN8140.

3. Mounting the insert on the handle holder.
Place the threaded insert on the handle holder. Use the adjusting ring to limit the working depth. The insert collar must be installed in the groove of the tool.

4. Installing the insert.
Install the threaded insert into the prepared hole.

5. Removing the driver.
Remove the driver of the threaded insert. Use a demolition jig.

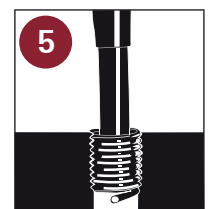
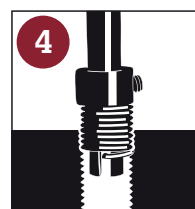
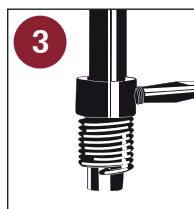
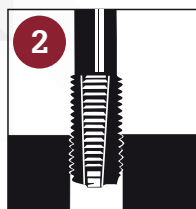

Thread repair kit

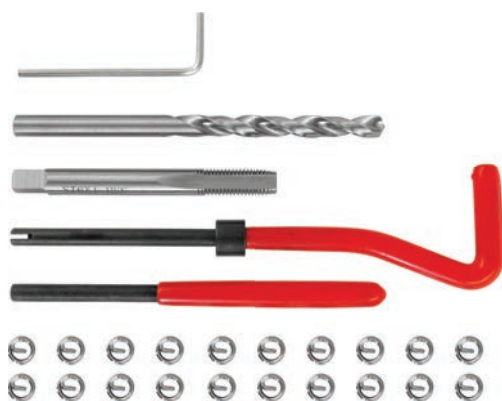

| Code | Item number | | Pcs |
|-------|-------------|----------|-----|
| 53172 | TRIS508 | M5x0.8 | 25 |
| 53173 | TRIS61 | M6x1.0 | 25 |
| 53185 | TRIS710 | M7x1.0 | 25 |
| 53183 | TRIS810 | M8x1.0 | 25 |
| 53174 | TRIS8125 | M8x1.25 | 25 |
| 53184 | TRIS9125 | M9x1.25 | 25 |
| 53175 | TRIS101 | M10x1.0 | 15 |
| 53176 | TRIS10125 | M10x1.25 | 15 |
| 53177 | TRIS1015 | M10x1.5 | 15 |
| 53178 | TRIS12125 | M12x1.25 | 15 |
| 53179 | TRIS1215 | M12x1.5 | 15 |
| 53180 | TRIS12175 | M12x1.75 | 15 |
| 53181 | TRIS14125 | M14x1.25 | 15 |
| 53182 | TRIS1415 | M14x1.5 | 15 |

Thread repair kit

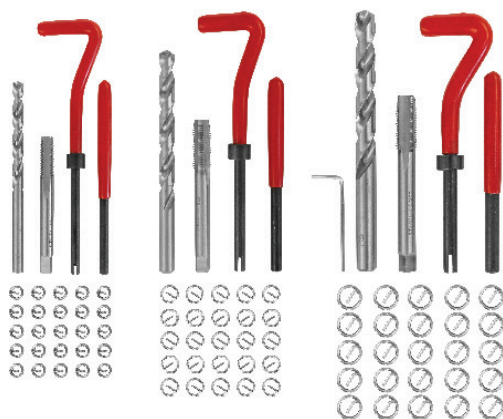

| Code | Item number | | Pcs |
|-------|-------------|----------|-----|
| 53170 | TRIS88 | M6x1.0 | 88 |
| | | M8x1.25 | |
| | | M10x1.5 | |
| 53171 | TRIS131 | M5x0.8 | 131 |
| | | M6x1.0 | |
| | | M8x1.25 | |
| | | M10x1.5 | |
| | | M12x1.75 | |

Thread inserts set



| Code | Item number | | Pcs |
|-------|-------------|----------|-----|
| 53186 | WTRI508 | M5x0.8 | 25 |
| 53187 | WTRI610 | M6x1.0 | 25 |
| 53188 | WTRI8125 | M8x1.25 | 25 |
| 53189 | WTRI101 | M10x1.0 | 10 |
| 53190 | WTRI10125 | M10x1.25 | 10 |
| 53191 | WTRI1015 | M10x1.5 | 10 |
| 53192 | WTRI12125 | M12x1.25 | 10 |
| 53193 | WTRI1215 | M12x1.5 | 10 |
| 53194 | WTRI12175 | M12x1.75 | 10 |
| 53195 | WTRI14125 | M14x1.25 | 10 |
| 53196 | WTRI1415 | M14x1.5 | 10 |

Thread repair kit M6-M12, 15 pcs.



| Code | Item No. | Working range, mm |
|--|----------|-------------------|
| 53218 | RTK15 | M6-M12 |
| Content (15 pcs): | | |
| Dies, 7 pcs.: M6x1.0; M8x1.25; M10x1.25; M10x1.50; M12x1.25; M12x1.50; M12x1.75; | | |
| Tips, 7 pcs.: M6x1.0; M8x1.25; M10x1.25; M10x1.50; M12x1.25; M12x1.50; M12x1.75; | | |
| Chrome vanadium steel file, 1 pcs., thread pitch: 0.75; | | |
| Plastic case. | | |

A set for restoring a thread of a spark plug hole M14, 5 pcs.



| Code | Item No. |  |
|---|----------|---|
| 53197 | SPTRS145 | 9.5-19 |
| Content (5 pcs): | | |
| Tap with hex shank for spark plug thread M14x1.25, self-centering; | | |
| Tread inserts 9.5 mm (3/8"), 11 mm (7/16"), 12.5 mm (1/2"), 19 mm (3/4"). | | |

A set for restoring a thread of a spark plug hole M14, 5 pcs.



| Code | Item No. |  |
|-------|-----------|---|
| 53199 | SPTRI1412 | 12.5 mm (1/2") |
| 53198 | SPTRI1434 | 19 mm (3/4") |

Stages of thread repair of a sparkplug hole

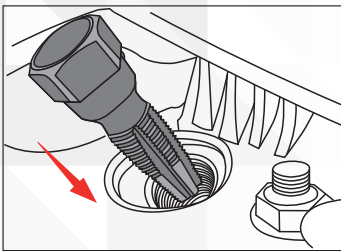

1. Thread cutting.
Cut the thread with a special tap M14x1.25

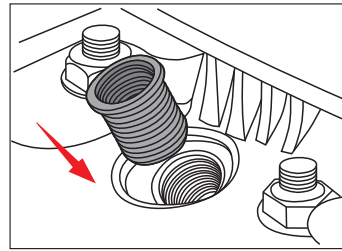

2. Installing the insert.
Install the threaded insert into the prepared hole.

A set for restoring a thread of a sump hole, 7 pcs.



| Code | Item No. |  |
|--|-----------|---|
| 53211 | ODPRK1315 | M13x1.5 |
| 53212 | ODPRK1515 | M15x1.5 |
| 53213 | ODPRK1715 | M17x1.5 |
| 53214 | ODPRK2015 | M20x1.5 |
| Content (7 pcs): | | |
| Taps M13x1.5, M15x1.5, M17x1.5, M20x1.5; | | |
| Treaded plug M13x1.5, M15x1.5, M17x1.5, M20x1.5 with aluminum sealing ring, 6 pcs. | | |

A set for restoring a thread of a sump hole, 64 pcs.



| Code | Item No. |  | Working range, mm | Quantity in a set, pcs |
|---|-----------|---|-------------------|------------------------|
| 53215 | ODPRK1320 | M13x1.5 | M13-M20 | 64 |
| | | M15x1.5 | | |
| | | M17x1.5 | | |
| | | M20x1.5 | | |
| Content (64 pcs): | | | | |
| Taps, 4 pcs.: M13x1.5, M15x1.5, M17x1.5, M20x1.5; | | | | |
| Treaded plug M13x1.5, M15x1.5, M17x1.5, M20x1.5, with sealing ring, 60 pcs. | | | | |



A set for restoring a thread of a sump hole, 114 pcs.



| Code | Item No. | | Working range, mm | Quantity in a set, pcs |
|---|-----------|----------|-------------------|------------------------|
| 53216 | ODPRK1322 | M13x1.25 | M13-M22 | 114 |
| | | M13x1.5 | | |
| | | M15x1.5 | | |
| | | M17x1.5 | | |
| | | M20x1.5 | | |
| | | M22x1.5 | | |
| Content (114 pcs): | | | | |
| Taps, 6 pcs.: M13x1.25, M13x1.5, M15x1.5, M17x1.5, M20x1.5; M22x1.5; | | | | |
| Treaded plug M13x1.25, M13x1.5, M15x1.5, M17x1.5, M20x1.5, M22x1.5, with sealing ring, 108 pcs. | | | | |

Tread restoration file



| Code | Item No. | Working range, mm |
|-------|----------|--|
| 53210 | TRF | 0.75, 1.0, 1.25, 1.5, 1.75, 2.0, 2.5, 3.0 mm |

Stud extractor, 1/2"DR

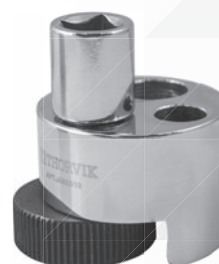

| Code | Item No. | Working range, mm |
|-------|----------|-------------------|
| 52352 | ASE619 | 6-19 |

Spiral socket for worn fasteners 1/2"DR



| Code | Item No. | Working range, mm |
|-------|----------|-------------------|
| 53219 | BES1217 | 17 |
| 53220 | BES1219 | 19 |
| 53221 | BES1221 | 21 |
| 53222 | BES1222 | 22 |

Tubing and hose handling tools

Tube flaring set, 10 pcs



| Code | Item No. | Working range, mm |
|--|----------|-------------------|
| 52507 | DFTS10 | 4-14 |
| Content (10 pcs): | | |
| Roller pipe cutter with a cutter for deburring; | | |
| Clamp from fixing tubes; | | |
| Punches for double flaring of tubes with diameters 4, 4.75, 6, 8, 10, 12, 14 mm; | | |
| Flaring tool; | | |
| Plastic case. | | |

Set for pipe flaring 4.75-6 with hydraulic drive, 16 pcs.



| Code | Item No. | Working range, mm |
|--|----------|-------------------|
| 53247 | BPFTH | 4,75-6 |
| Content (16 pcs): | | |
| Housing tool; | | |
| Body clamp; | | |
| Countersink manual; | | |
| Handle; | | |
| Hydraulic drive; | | |
| Tube matrix III 4.75(3/16"), 5.00, 6.35 (1/4") mm; | | |
| Punches for tubes; | | |
| Plastic case. | | |

Manual tube bender for pipes with a diameter of 4.75-10 mm



| Code | Item No. | Working range, mm |
|-------|----------|-------------------|
| 53244 | BPB1 | 4.75-10 |

Manual tube bender for pipes with a diameter of 3-6 mm



| Code | Item No. | Working range, mm |
|-------|----------|-------------------|
| 53245 | BPB2 | 3-6 |

A set of plastic clips for rubber hoses and pipes, 3-57 mm, 3 pcs.



| Code | Item No. | Working range, mm |
|-------|----------|-------------------|
| 53257 | HCS3 | 5-57 |

Metal hose clamps set, 4 pcs.

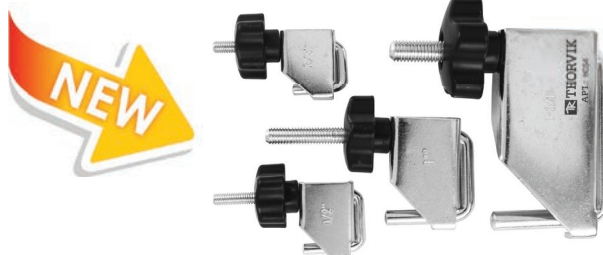

| Code | Item No. | Working range, mm |
|-------|----------|-------------------|
| 53249 | HCS4 | 10-45 |

CHASSIS REPAIR AND MAINTENANCE TOOL.

Suspension tool.

Nozzle with radial spikes for mounting/dismounting of shock absorber of VAG cars

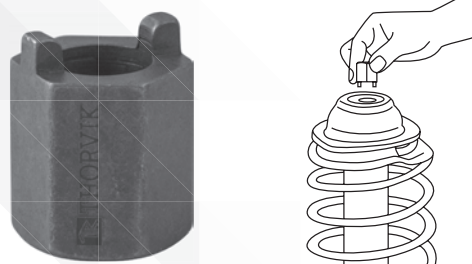

| Code | Item No. | Drive size, mm |
|-------|----------|----------------|
| 52353 | ASSS22 | 22 |

Ball joint remover



| Code | Item No. | Capture size, mm |
|-------|----------|------------------|
| 52313 | ABJS3 | 19 |

Ball joint extractor, 33 mm

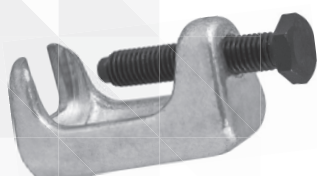

| Code | Item No. | Capture size, mm |
|-------|----------|------------------|
| 52309 | ABJP1 | 33 |

Ball joint remover

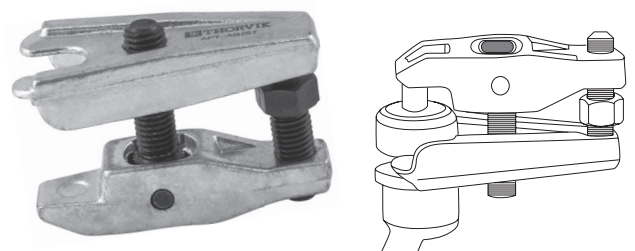

| Code | Item No. | Capture size, mm |
|-------|----------|------------------|
| 52311 | ABJS1 | 22 |

Ball joint remover with extended capture, 17 mm

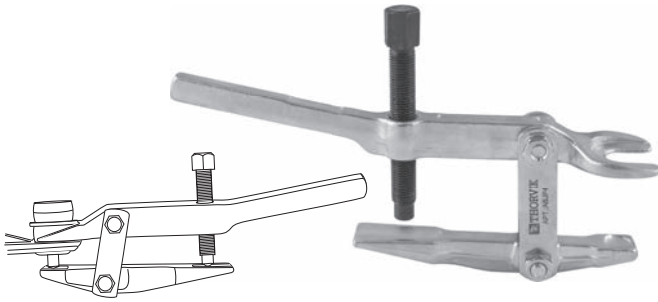

| Code | Item No. | Capture size, mm |
|-------|----------|------------------|
| 52310 | ABJP4 | 17 |

Ball joint separator

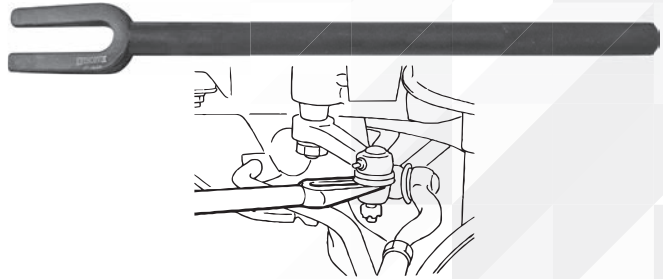

| Code | Item No. | Length, mm | Capture size, mm |
|-------|----------|------------|------------------|
| 52307 | ABJE30 | 300 | 16,5 |
| 52308 | ABJE40 | 400 | 22 |

Coil spring compressor, 2 pcs



| Code | Item No. | Working size, mm |
|-------|----------|------------------|
| 52350 | ASC27 | 270 |
| 52351 | ASC37 | 370 |

Ball joint remover with variable height grip

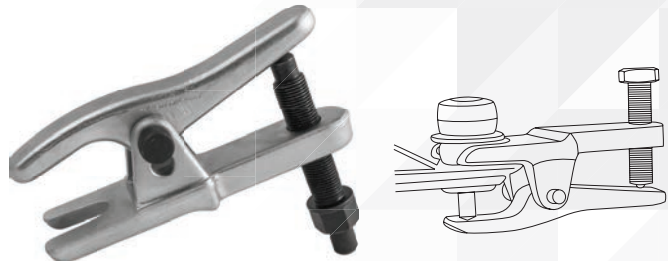

| Code | Item No. | Capture size, mm |
|-------|----------|------------------|
| 52312 | ABJS2 | 22 |

Device for installing clamps with cutter

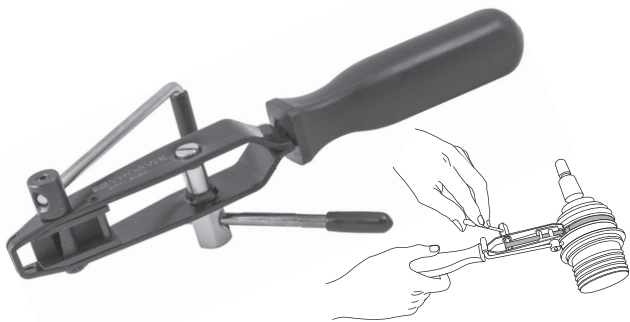

| Code | Item No. |
|-------|----------|
| 52315 | ACBT |

Boot clamp pliers

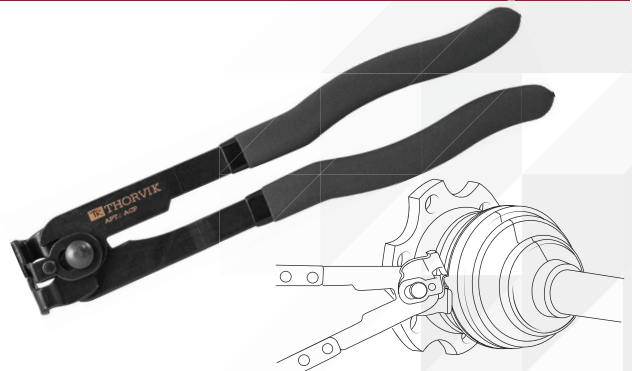

| Code | Item No. |
|-------|----------|
| 52318 | ACP |

Heavy duty boot clamp pliers



| Code | Item No. |
|-------|----------|
| 52633 | ACP2 |

MacPherson spring dumper extractor/installer



| Code | Item No. |
|--|----------|
| 52637 | AMSCK |
| Content (8 pcs): | |
| Working cylinder, 1 pcs; | |
| Spring grippers, 6 pcs: Ø 80-115 mm - 2 pcs, Ø 110-150 mm - 2 pcs, Ø 140-195 mm - 2 pcs; | |
| Taper spring adapter, 1 pcs; | |
| Plastic case. | |

Remove and install the hub and bearing installer set, 20 pcs



| Code | Item No. |
|--|----------|
| 52636 | AFWBK |
| Content: | |
| Lead screw, 1 pcs; | |
| Bearing shell, 3 pcs: Ø 76, 86, 91 mm; | |
| Mandrel, 9 pcs: Ø 55.5, 59, 62, 65, 66, 71.5, 73, 78, 84 mm; | |
| Bolts, 6 pcs: M12x1.5 - 3 pcs, M14x1.5 - 3 pcs; | |
| Plastic case. | |

Bush extractor set, 44-82 mm, 24 pcs

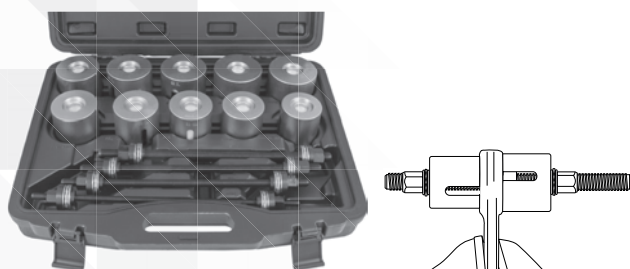

| Code | Item No. |
|--|----------|
| 52638 | APPS24 |
| Content: | |
| Lead screw with nuts, 4 pcs: M10, M12, M14, M16; | |
| Mandrel inner / outer diameter, 20 pcs: Ø 34/44, 36/46, 38/48, 40/50, 42/52, 44/54, 46/56, 48/58, 50/60, 52/62, 54/64, 56/66, 58/68, 60/70, 62/72, 64/74, 66/76, 68/78, 70/80, 72/82 mm; | |
| Plastic case. | |

Universal tool for bishing replacement in a set, 44-90 mm



| Code | Item No. |
|--|----------|
| 53008 | APPS27 |
| Content: | |
| Leads screw with nuts, 5 pcs: M10, M12, M14, M16, M18; | |
| Mandrel inner/outer diameter, 22 pcs: III 34/44, 36/46, 38/48, 40/50, 42/52, 44/54, 46/56, 48/58, 50/60, 52/62, 54/64, 56/66, 58/68, 60/70, 62/72, 64/74, 66/76, 68/78, 70/80, 72/82 mm, 75/85 mm, 80/90 mm; | |
| Plastic case. | |

Brake system tools

Brake caliper piston tool

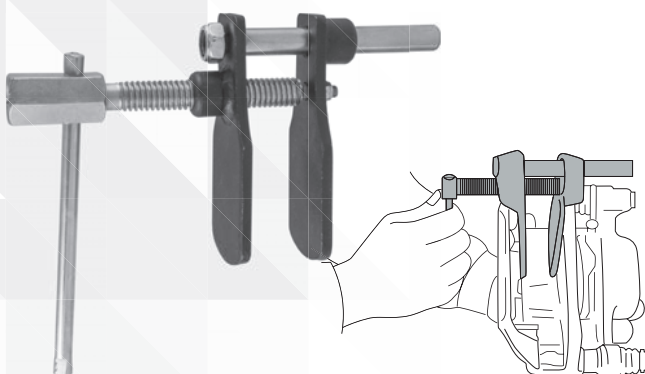

| Code | Item No. |
|-------|----------|
| 52320 | ADBPS2 |

Brake caliper piston tool

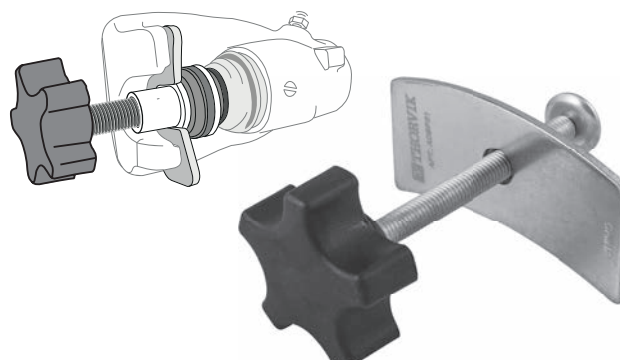

| Code | Item No. |
|-------|----------|
| 52319 | ADBPS1 |

Brake caliper piston tool



| Code | Thread direction | Item No. |
|-------|------------------|----------|
| 52317 | Right | ACPTS3 |
| 53234 | Left | ACPTS3L |

Caliper wind back tool set

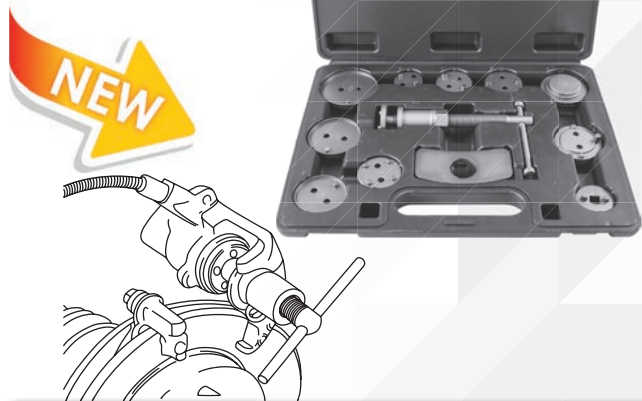

| Code | Quantity, pcs. | Thread direction | Item No. |
|-------|----------------|------------------|----------|
| 52316 | 12 | Right | ACPTK12 |
| 53229 | 18 | Right, left | ACPTK18 |

Lead screw for brake caliper piston tool



| Code | Thread direction | Item No. |
|-------|------------------|----------|
| 53231 | Right | ACPTKR |
| 53230 | Left | ACPTKL |

Caliper wind back tool set, 7 pcs

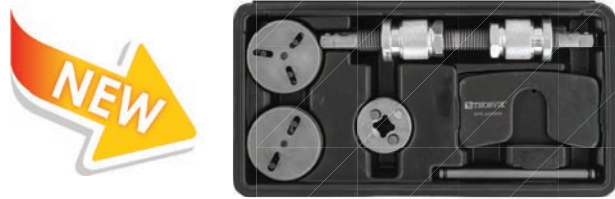

| Code | Item No. |
|--|----------|
| 53233 | ABCRT2 |
| Content, (7 pcs): | |
| Lead screw with handle, left and right screw direction | |
| Bushing for lead screw right thread | |
| Bushing for lead screw left thread | |
| Thrust plate | |
| Basic head | |
| Head with two guides adjustable in width | |
| Head with three guides adjustable in width | |
| Plastic case | |

Caliper wind back tool with pneumatic drive in a set, 16 pcs



| | |
|--|--|
| Content (16 pcs): | |
| 0 - \varnothing 60 mm, with flange connection and one guide, for GM vehicles; | |
| 2 - \varnothing 50 mm, with flange connection and three guides, for Citroen XM and Xantia vehicles; | |
| 3 - \varnothing 35/42/53 mm, for various vehicles; | |
| 4 - \varnothing 30 mm, with flange connection and two guides, for Alfa Romeo 164 2.0, Saab 9000, Hond Prelude; | |
| 5 - \varnothing 32 mm, with flange connection, two guides, and drive 3/8"DR, for Mazda 323/626, Toyota; | |
| 6 - \varnothing 40 mm, with flange connection and two guides, for VW, Nissan; | |
| 7 - \varnothing 40 mm, with flange connection and two guides, for various european and japan vehicles; | |
| 8 - \varnothing 45 mm, with flange connection and one guides, for GM vehicles; | |
| 9 - \varnothing 52 mm, with flange connection and one guides, for Citroen C5; | |
| A - \varnothing adapter 3/8" DR with flange connection and two guides; | |
| E - \varnothing 40 mm, with flange connection and four guides, for Nissan Maxima; | |
| F - \varnothing 28 mm, with flange connection and two guides, for Opel vehicles; | |
| K - \varnothing 53 mm, with flange connection and three guides, for Citroen CXM L; | |
| M - \varnothing 31 mm, with flange connection and two guides, for Ford Mondeo; | |
| N - \varnothing 30 mm, with flange connection and HEX 12 mm, for Saab/Honda vehicles; | |
| Pneumatic drive; | |
| Plastic case. | |

| Code | Item No. |
|-------|----------|
| 53232 | ACPTK16P |

Universal drive for the return of pistons of disc brakes, 3/8"DR

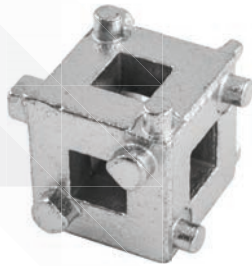

| Code | Item No. |
|-------|----------|
| 53236 | ABPT |

Disc brake piston return device



| Code | Item No. |
|-------|----------|
| 53235 | ARBCP |

Brake service tool set, 8 pcs.



| Code | Item No. |
|-------|----------|
| 53251 | BTS |

Content (8 pcs):

- Universal pliers for disassembly brake springs;
- Device for assembly/disassembly of pressure springs (ø 15.9 mm (5/8") drum brake pads;
- Device for assembly/disassembly of pressure springs (ø 19 mm (3/4") and (ø 20.6 mm (13/16") drum brake pads;
- Device for assembly/disassembly of pressure springs (ø 15.9 mm (5/8") drum brake pads;
- Device for assembly/disassembly of pressure springs (suitable for the braking system of most car brands);
- Three mounting blades for adjusting;
- Plastic case.

Universal pliers for disassembly brake springs;



| Code | Item No. |
|-------|----------|
| 53250 | BSCP |

Hook puller for disassembly drum brake springs, headlight adjustment.



| Code | Item No. |
|-------|----------|
| 53248 | BSRH |

Device for assembly/disassembly of pressure springs drum brake pads;



| Code | Item No. |
|-------|----------|
| 53252 | BRSC |

A set of 5-point sockets and bit sockets for servicing brake mechanisms 1/2"DR, 3 pcs.



| Code | Item No. |
|-------|----------|
| 53237 | PBCSS3 |

Content (3 pcs):

- Sockets 5-points, 1/2"DR, 2 pcs: 14, 19 mm;
- Bit socket, 1/2"DR, 10 mm;
- Plastic case.

A set of 5-point sockets and bit sockets for servicing brake mechanisms 1/2"DR, 3 pcs.



| Code | Item No. |
|---|----------|
| 53238 | PBCSS5 |
| Content (3 pcs): | |
| Sockets 5-points, 1/2"DR, 4 pcs: 10, 12.5, 14, 19 mm; | |
| Bit socket, 1/2"DR, 10 mm; | |
| Plastic case. | |

Set of adapters for servicing brake mechanism 3/8"DR, H7, H8, 2 pcs.



| Code | Item No. |
|-------|----------|
| 53255 | ASBS78 |

Set of bit sockets for servicing brake mechanism 3/8"DR, H7, H9, 2 pcs.



| Code | Item No. |
|-------|----------|
| 53256 | ASBS79 |

Hand use device for brake fluid replacement.



| Code | Item No. |
|---------------------------|----------|
| 53242 | BCBS |
| Content: | |
| Device | |
| Drain reservoir with hose | |

Manual use device with the help of which work is carried out on pressure testing (pumping) of hydraulic circuits of brake drives, clutch working cylinders and replacement of working fluids.

Device with a pneumatic drive for brake fluid replacement.



| Code | Item No. |
|---|----------|
| 53240 | PBB1 |
| Content: | |
| Reservoir for filling liquid, 1.0 liter; | |
| Reservoir for draining the waste liquid, assembled with a vacuum gun; | |
| Transparent hose; | |
| Adapter, 4 pcs.: 25/32" – 1-7/32" (21-30 mm), 31/32" – 1-1/4" (24-32 mm), 1-3/32" – 1-15/32 (28-37 mm), 1-1/4" – 1-19/32" (32-41 mm). | |

The device with a pneumatic drive, with the help of which work is carried out on pressure testing (pumping) of hydraulic circuits of brake drives, clutch working cylinders and replacement of working fluids.

Adapter for PBB1



Code
53241

Item No.
PBBAD

Brake fluid tester



Code
53243

Item No.
BFT

Vacuum tester for tightness test, set, 19 pcs.



Code
53253

Item No.
VPP

Content (19 pcs):

- Manual pump with pressure gauge, assembled;
- Reservoir for draining the waste liquid, with a cap;
- Transparent hose, 4 pcs;
- Fittings and adapters, 4 pcs;
- Plastic case.

■ The device is used to test or service various vehicle systems using either a vacuum pump or a pump that builds up overpressure.

Tools for shafting.

Clutch alignment tool, 9 pcs

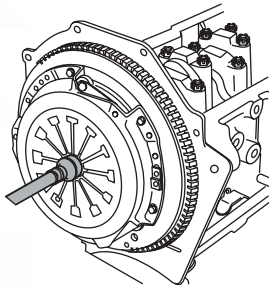

Code
52314

Item No.
ACATS10

Content (9 pcs):

18x11; 18x12; 18x15; 18x17; 18x19; 18x20; 18x21; 18x25; 82x20,5 mm.

Steering tool

Device for dismantling the steering gear



Code
52330

Item No.
AITRD1

Capture range, mm
33-42

Eccentric wrench for dismantling the steering gear



Code
52357

Item No.
ATRW24

Capture range, mm
27-42

Pitman arm puller



| Code | Item No. | Capture size, mm |
|-------|----------|------------------|
| 52345 | APAP1 | 33 |

Thread restoration set of the CV-joint axle, 8 pieces

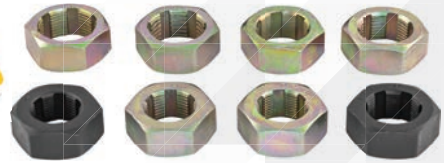

| Code | Item No. |
|--|----------|
| 53217 | CVJRTK |
| Content (8 pcs): | |
| Dies for wrench or socket 1-1/4", 8 pcs.: M24x1.5, M24x2.0, M22x1.0, M22x1.5, M20x1.5, M20x1.25, 13/16"x20 UNEF, 3/4"x20 UNEF; | |
| Plastic case. | |

■ The thread restoration set is intended for repairing worn out or damaged threads of the CV-joint axle of motor vehicles..

BODY REPAIR AND MAINTENANCE TOOL.

Body alignment tools

Battery terminals and wiper arms puller



| Code | Item No. |
|-------|----------|
| 52362 | AWAP1 |

Puller trim caps door trim with U-shaped grip



| Code | Item No. | Length, mm |
|-------|----------|------------|
| 52356 | ATPR10 | 100 |

Dent puller set, 13 pcs



| Content (13 pcs): |
|--------------------|
| Striker, 10 pound; |
| Guide; |
| Hook 90° short; |
| Hook 90° long; |
| Hook 45° short; |
| Hook 45° long; |
| Paddle short; |
| Paddle long; |
| Handle with chain; |
| Handle; |
| Double bushing; |
| Punch; |
| Shim; |
| Plastic case. |

| Code | Item No. |
|-------|----------|
| 52634 | ADPS13 |



Set of tools for removing a vehicle interior decorative panels, 5 pcs

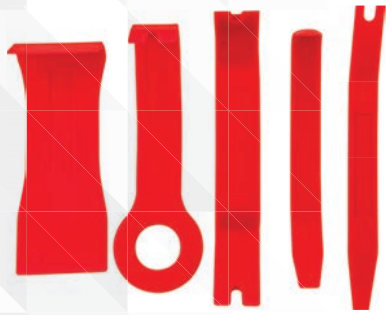

| Code | Item No. |
|--|----------|
| 52358 | AURTS5 |
| Content (5 pcs): | |
| Wedge-shaped puller; | |
| Wedge-shaped puller with a clip for clips; | |
| Clips Remover; | |
| Wide puller; | |
| Hook remover. | |

Set of tools for removing a vehicle interior decorative panels, 6 pcs.

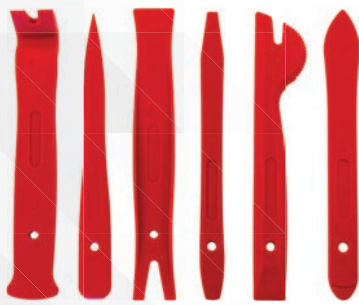

Set of tools for removing a vehicle interior decorative panels, 11 pcs.



| Code | Item No. |
|-------|----------|
| 52797 | AURTS6 |

| Code | Item No. |
|-------|----------|
| 52798 | AURTS11 |

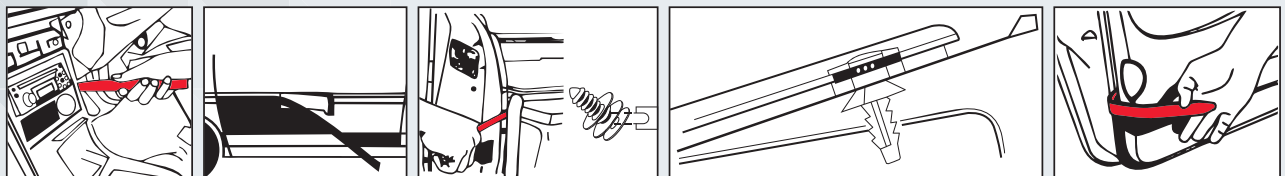

ENGINE REPAIR AND MAINTENANCE TOOL

Tool for working with a cylinder-piston engine part.

Piston ring compressor

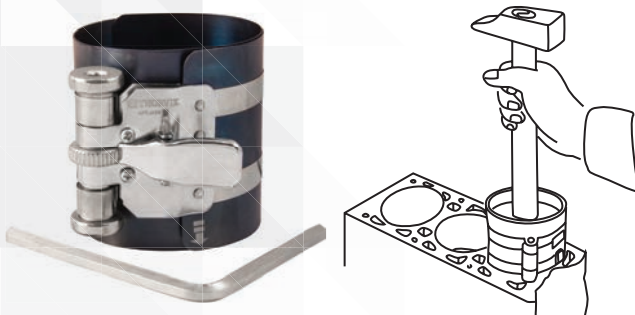

Piston Ring Pliers

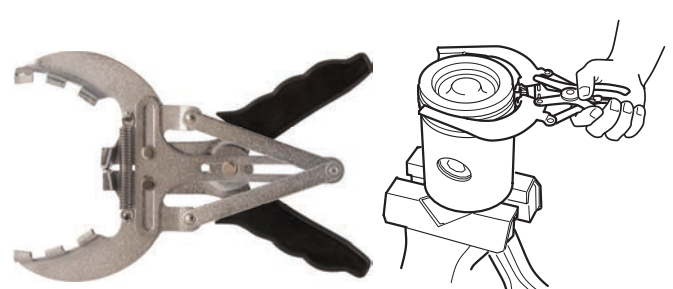

| Code | Item No. | Height,mm | Working range, mm |
|-------|----------|-----------|-------------------|
| 52346 | APRC3 | 76 | 53-175 |
| 52347 | APRC4 | 100 | 90-175 |

| Code | Item No. | Working range, mm |
|-------|----------|-------------------|
| 52348 | APRP4 | 50-100 |
| 52349 | APRP6 | 80-120 |

Gas distribution mechanism tool

Valve seal removal pliers

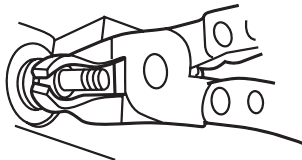

| Code | Item No. | Length, mm |
|-------|----------|------------|
| 52361 | AVSP25 | 250 |
| 52506 | AVSP27 | 270 |

Valve spring lifter

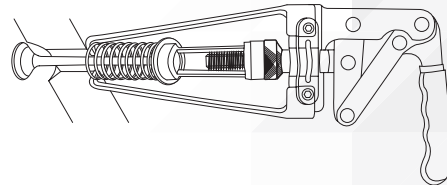
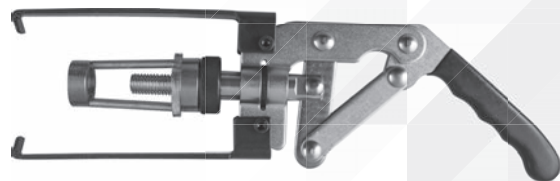

| Code | Item No. |
|-------|----------|
| 52359 | AVSC25 |

Valve spring compressor set, 16-30 mm, 8 pcs



| Code | Item No. | Length, mm |
|-------|----------|------------|
| 52639 | AVSCS2 | 300 |

Content (8 pcs):
 Clamp, 1 pcs;
 Stop screw, 2 pcs;
 Clamping sleeves, 5 pcs: 16, 19, 23, 25, 30 mm;
 Plastic case.

Valve spring compressor set

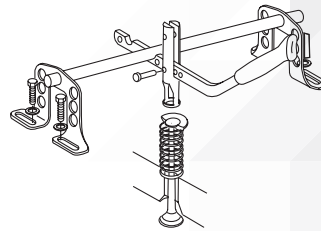

| Code | Item No. |
|-------|----------|
| 52360 | AVSCS1 |

Tool for ruel system

Oxygen sensor wrench



| Code | Item No. | Drive size | Working size, mm |
|-------|----------|------------|------------------|
| 52344 | AOS11278 | 1/2"DR | 22 |

Tool for working with the lubrication system

A set of devices for loosening oil plugs, 12 pcs

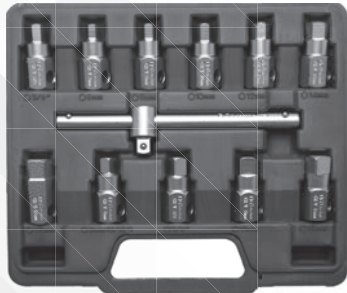

| Code | Item No. |
|---|----------|
| 52332 | AODTS12 |
| Content (12 pcs): | |
| 3/8"DR: | |
| HEX inserts, 7 pcs: 8 mm, 9 mm, 3/8"(9.5 mm), 10 mm, 12 mm, 14 mm, 17 mm; | |
| Tetrahedral inserts, 4 pcs: 8 mm, 3/8"(9.5 mm), 11 mm, 13 mm; | |
| Handle; | |
| Plastic case. | |

Oil filter cup, 14 points



| Code | Item No. | Working size, mm |
|-------|----------|------------------|
| 52337 | AOFW6514 | 65 |
| 52338 | AOFW7614 | 76 |

Oil filter wrench with cylindrical grippers

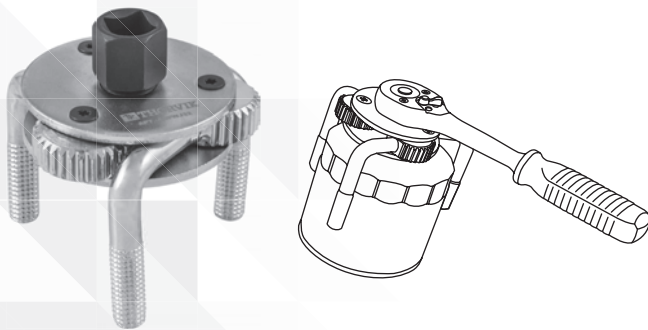

| Code | Item No. | Working range, mm |
|-------|----------|-------------------|
| 52341 | AOFWJ32 | 65-120 |

Oil filter wrench with flat grips

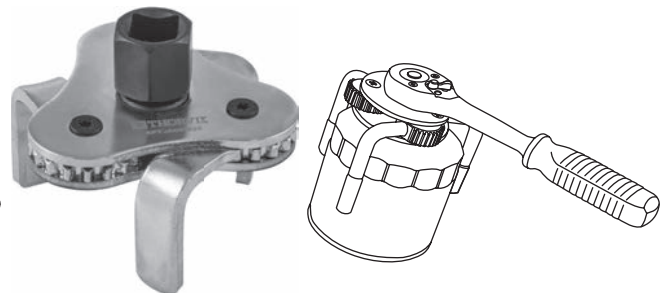

| Code | Item No. | Working range, mm |
|-------|----------|-------------------|
| 52342 | AOFWJ3 | 65-100 |

Oil filter chain wrench



| Code | Item No. | Drive size | Chain length, mm | Working range, mm |
|-------|----------|----------------------|------------------|-------------------|
| 52334 | AOFCW45 | 1/2"DR, 16 mm HDR | 450 | up to 120 |

Chain wrench



| Code | Item No. | Length, mm | Working range, mm |
|-------|----------|------------|-------------------|
| 52333 | AOFCW25 | 230 | 60-120 |

Strap wrench



| Code | Item No. | Length, mm | Working range, mm |
|-------|----------|------------|-------------------|
| 52339 | AOFWB23 | 230 | up to 110 |
| 52340 | AOFWB30 | 280 | up to 220 |

Oil filter pliers



| Code | Item No. | Working range, mm |
|-------|----------|-------------------|
| 52335 | AOFP25 | 50-85 |
| 52336 | AOFP30 | 60-115 |

Oil filter cup wrenches set, 14 pcs



| Code | Item No. | Working range, mm |
|-------|----------|-------------------|
| 52343 | AOFWS14 | 65-100 |

Content (14 pcs):
 Oil filters:
 65 mm - 14 g; 65/67 mm - 14 g; 68 mm - 14 g; 74 mm - 15 g; 76 mm - 30 g;
 76 mm - 14 g; 74/76 mm - 15 g; 75/77 mm - 15 g; 80 mm - 15 g; 80/82 mm - 15 g;
 90 mm - 15 g; 93 mm - 15 g; 93 mm - 36 g; 100 mm - 15 g;
 Adapter 1/2"(F) - 3/8"(M);
 Plastic case.

A tool for working with the cooling system and climatic equipment

Flexible hose clamp



| Code | Item No. |
|-------|----------|
| 52635 | AFHP |

Cooling system tightness test kit, 18 pcs.



Состав (18 предметов):

- RPTS18-19 Connector R123/125 Black;
- RPTS18-18 Connector R123/124 Blue;
- RPTS18-17 Special wrench for mounting the adapter;
- RPTS18-16 Adapter, pink. Mazda;
- RPTS18-15 Adapter, yellow. Ford;
- RPTS18-14 Adapter, blue, MB (W140, 124, 210, 211, 215, 216);
- RPTS18-13 Adapter, green. Ford, Land Rover, Opel;
- RPTS18-12 Adapter, red. VW, Audi;
- RPTS18-11 Adapter, gray. BMW (E32, 34, 36, 38, 39, 46, 90);
- RPTS18-08 Adapter, brown. Volvo, Saab, PSA, Renault;
- RPTS18-10 Adapter, black. VW, Audi. BMW, Porsche;
- RPTS18-09 Adapter, black. VW;
- RPTS18-07 Adapter, orange. MB (ML, W163, W164), GM;
- RPTS18-06 Adapter, Chrysler, Japanese vehicles;
- RPTS18-05 Adapter, PSA, MB, GM, Chrysler, Japanese vehicles;
- RPTS18-04 Adapter, MB (W123, 124, 126, 201). GM, Jeep;
- RPTS18-03 Thermometer;
- RPTS18-02 Manual pump with manometer and hose;
- Plastic case.

| Code | Item No. |
|-------|----------|
| 52891 | RPTS18 |

AUXILIARY TOOL

Flexible magnetic pick up tool



| Code | Item No. | Length, mm | Capacity, KG |
|-------|-----------|------------|--------------|
| 52888 | FMPT4522 | 450 | 2,2 |
| 52889 | FMPT45236 | 450 | 3,6 |

Telescopic magnetic handle



| Code | Item No. | Length range, mm | Capacity, KG |
|-------|----------|------------------|--------------|
| 52890 | MTPT1365 | 130-641 | 1,5 |

Telescopic mirror



| Code | Item No. | Diameter, mm | Working range, mm |
|-------|----------|--------------|-------------------|
| 52355 | ATIM32 | 30 | 170-495 |

Stethoscope for detecting defects in mechanic



| Code | Item No. |
|-------|----------|
| 52331 | AMS |

Universal brush



| Code | Item No. | Length, mm |
|-------|----------|------------|
| 53254 | MCB | 230 |

Bottle opener



| Code | Item No. |
|-------|----------|
| 91034 | 547101 |

TOOL FOR TYRE REPAIR

L-handle socket wrench

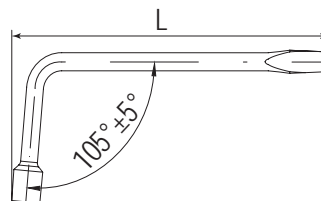

| Code | Item No. | Size, mm | L, mm | kg | pcs | kg |
|-------|----------|----------|-------|------|-----|----|
| 52512 | LHTW3517 | 17 | 350 | 0,52 | 50 | 27 |
| 52513 | LHTW3519 | 19 | 350 | 0,54 | 50 | 28 |
| 52514 | LHTW3521 | 21 | 350 | 0,54 | 50 | 28 |

Adjustable L-handle socket wrench

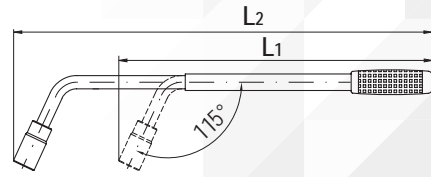

| Code | Item No. | Size, mm | L1, mm | L2, mm | kg | pcs | kg |
|-------|-----------|----------|--------|--------|------|-----|----|
| 52508 | TLHTW1719 | 17x19 | 380 | 550 | 1,05 | 20 | 22 |

Cross-handle socket wrench

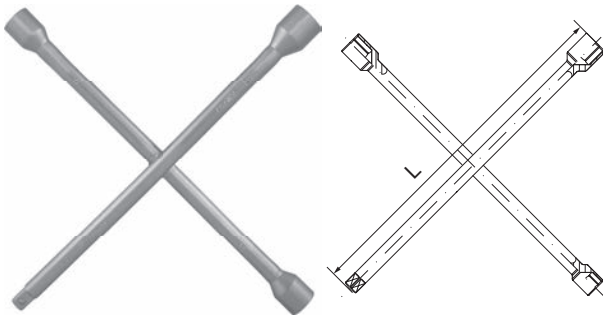

| Code | Item No. | Size, mm | L, mm | kg | pcs | kg |
|-------|----------|-----------------|-------|-----|-----|----|
| 52509 | CRTW35 | 17x19x21x1/2'DR | 350 | 1,2 | 20 | 25 |

Heavy duty cross-handle socket wrench

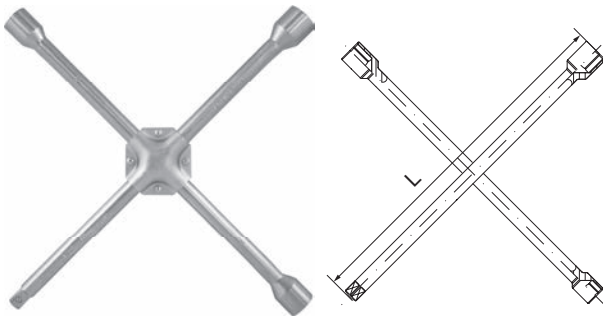

| Code | Item No. | Size, mm | L, mm | kg | pcs | kg |
|-------|----------|-----------------|-------|-----|-----|----|
| 52510 | CRTW38 | 17x19x21x1/2'DR | 380 | 1,3 | 20 | 27 |

Heavy duty cross-handle socket wrench with adapter

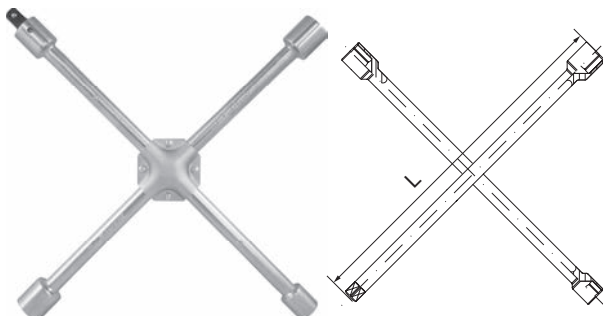

| Code | Item No. | Size, mm | L, mm | kg | pcs | kg |
|-------|----------|--------------------|-------|-----|-----|----|
| 52511 | CRTW40AD | 17x19x21x22*1/2'DR | 400 | 1,4 | 20 | 29 |

* Adapter 19 mm HDRx1/2'DR included.

Tire piston inflator



| Code | Item No. |
|-------|----------|
| 52650 | ATIG1 |

3 function tire gauge

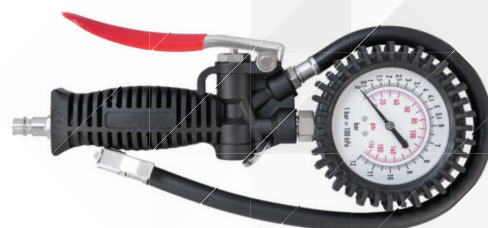







| Code | Item No. |
|-------|----------|
| 52651 | ATIG2 |

Cutting tool

The widest in range tool group, designed to change the shape and size of the workpiece by removing part of the material in the form of cuttings to obtain a finished part or semi-finished product. The cutting tool can be, both manual and machine - for use with the help of mechanization.

TM THORVIK® offers its customers a cutting tool for manual processing of various materials, for example, files, as well as metal twist drills for working with manual mechanized tools and using machine tools.



| | | | | | | | |
|--|---|---|---|---|----------------------------|---|--------------------------------------|
| DIN | According to DIN standart | HSS Co | High-speed steel with cobalt content | TiN | Coating - Titanium Nitride |  | Allows to process steel |
| HSS | High-speed steel |  | The angle at the top of the drill is 118° | Bronze | Bronze coating |  | Allows to process non-ferrous metals |
|  | High-speed steel without additional coating |  | The angle at the top of the drill is 135° |  | Allows to process steel |  | Allows machining plastics |
| | | | | | | INOX | Allows to process stainless steels |



Positioning air grinder at the angle of 90°



Positioning air grinder at the angle less than 90°



Weight of one item



Quantity in the package / shipping box



Packing weight (gross) / shipping box (gross)

FILES AND FILE SETS

The range of TM Thorvik metalwork files are represented by a product line of various profiles and types of notches. High degree of hardening - up to 62 HRC and a stable ratio of tooth height to the notch pitch across the entire working surface provide greater wear resistance of files and allow the use of tools for processing high-hardness materials. Products are equipped with ergonomic two-component handles.

Files

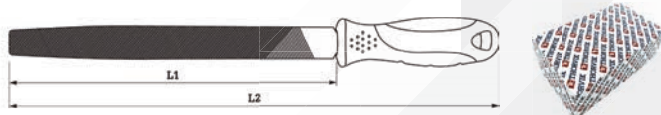

| Code | Item No. | Form | Notch type | L1, mm | L2, mm | kg | pcs | kg |
|-------|----------|------|------------|--------|--------|------|-----|----|
| 52281 | MFFS200 | | Double | 200 | 300 | 0,15 | 100 | 17 |
| 52282 | MFHS200 | | Double | 200 | 300 | 0,15 | 100 | 17 |
| 52283 | MFRS200 | | Double | 200 | 300 | 0,09 | 100 | 11 |
| 52284 | MFSS200 | | Double | 200 | 300 | 0,1 | 100 | 12 |
| 52286 | MFTS200 | | Double | 200 | 300 | 0,15 | 100 | 17 |

File set



| Code | Item No. | kg | pcs | kg |
|----------|----------|-----|-----|----|
| 52285 | MFSS205 | 700 | 20 | 13 |
| Content: | | | | |

Hon for boring hydraulic cylinders

The tool is designed for finishing and removing small scuffs and scratches on the surface of hydraulic cylinders of brake mechanisms of various vehicles.

Hon for boring hydraulic cylinders assembly



Replaceable Hon Bits for Boring Hydraulic Cylinders

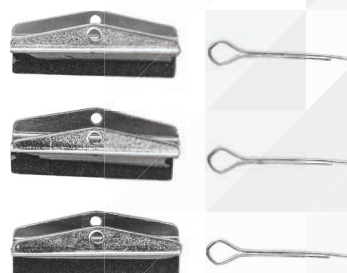

| Code | Item No. | Working range, mm |
|-------|----------|-------------------|
| 53258 | BCH3 | 19-64 |

| Code | Item No. | Size, mm |
|-------|----------|----------|
| 53259 | BCH3 | 28,5 |

MOUNTED POINTS

TM Thorvik profile mounted points used in processing of metal products for deburring, scale, clean grinding, beveling and chamfering, processing of corrugated surfaces and grooves. TM Thorvik mounted points are designed to work with straight grinders with a rigid or flexible extended drive.

Universal profile mounted points in a set, Ø 6 mm, 10 pcs



| Code | Item No. | kg | pcs | kg |
|-------------------------------|----------|-------|-------|------|
| 52632 | GSK10 | 0,22 | 40,00 | 10,9 |
| Content (10 pcs): | | | | |
| The shape of the working part | D/T, mm | L, mm | d, mm | |
| 1 Sphere | 22/22 | 49 | 6 | |
| 2 Cylinder | 25/12 | 43 | 6 | |
| 3 Cylinder | 24/36 | 52 | 6 | |
| 4 Cone | 18/25 | 54 | 6 | |
| 5 Dome | 20/25 | 65 | 6 | |
| 6 Dome | 19/28 | 56 | 6 | |
| 7 Cylinder | 16/16 | 58 | 6 | |
| 8 Sphere cylinder | 13/26 | 56 | 6 | |
| 9 Cone | 14/28 | 47 | 6 | |
| 10 Cone cylinder | 16/20 | 48 | 6 | |

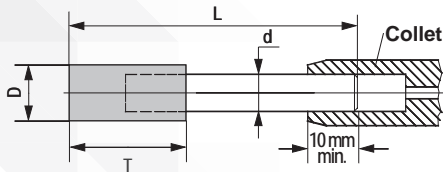

DISKS

Discs are cutting tools based on aluminum oxide (corundum), designed for cutting and grinding work.

Item number: ART.: AGD1156 (left), ART.: AFD115P60 (right)

Name: ДИСК ШЛИФОВАЛЬНЫЙ (left), ДИСК шлифовальный лепестковый (right)

Grit: A24 O BF (left), A60 (right)

Safety standards: (indicated by icons on both discs)

Specification, cutting conditions, dimensions: 13300 ОБ./МИН. 80 М/С (left), 115 x 22,2 мм 15300 об./мин. 80 м/с (right)

Processed material: СТАЛЬ (left), (right)

Safety instructions when working with disks:



When working, be sure to use eye and hearing protection, a respirator and protective gloves!



Do not use damaged discs during operation.

Abrasive cutting disc for metal

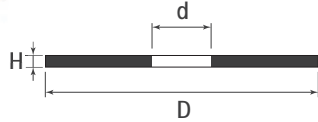

| Code | Item No. | D, mm | d, mm | H, mm | Quantity in a package |
|-------|----------|-------|-------|-------|-----------------------|
| 52366 | ACD11512 | 115 | 22 | 1.2 | 50 |
| 52367 | ACD11516 | 115 | 22 | 1.6 | 50 |
| 52368 | ACD11525 | 115 | 22 | 2.5 | 50 |
| 52370 | ACD12512 | 125 | 22 | 1.2 | 50 |
| 52371 | ACD12516 | 125 | 22 | 1.6 | 50 |
| 52372 | ACD12525 | 125 | 22 | 2.5 | 50 |
| 52775 | ACD15012 | 150 | 22 | 1.2 | 1 |
| 52776 | ACD15016 | 150 | 22 | 1.6 | 1 |
| 52374 | ACD18016 | 180 | 22 | 1.6 | 50 |
| 52375 | ACD18020 | 180 | 22 | 2.0 | 50 |
| 52376 | ACD18025 | 180 | 22 | 2.5 | 50 |
| 52377 | ACD23020 | 230 | 22 | 2.0 | 50 |
| 52378 | ACD23025 | 230 | 22 | 2.5 | 50 |
| 52379 | ACD23030 | 230 | 22 | 3.0 | 50 |
| 52777 | ACD30030 | 300 | 25.4 | 3.0 | 1 |
| 52778 | ACD35535 | 355 | 25.4 | 3.5 | 1 |
| 52779 | ACD40040 | 400 | 32 | 4.0 | 1 |

Grinding abrasive disc for metal

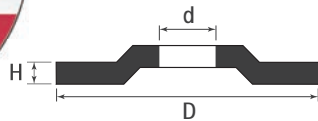

| Code | Item No. | D, mm | d, mm | H, mm | Quantity in a package |
|-------|-----------|-------|-------|-------|-----------------------|
| 52369 | AGD 11560 | 115 | 22 | 6 | 25 |
| 52373 | AGD12560 | 125 | 22 | 6 | 25 |

Petal grinding disc

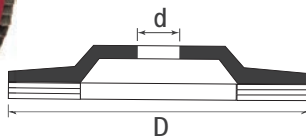

| Code | Item No. | D, mm | d, mm | Grit | | Quantity in a package |
|-------|------------|-------|-------|----------|-----------|-----------------------|
| | | | | ISO-6344 | Size, mcm | |
| 52380 | AFD115P40 | 115 | 22.2 | p40 | 400-500 | 10 |
| 52381 | AFD115P60 | 115 | 22.2 | p60 | 250-315 | 10 |
| 52382 | AFD115P80 | 115 | 22.2 | p80 | 200-250 | 10 |
| 52383 | AFD115P100 | 115 | 22.2 | p100 | 125-160 | 10 |
| 52384 | AFD125P40 | 125 | 22.2 | p40 | 400-500 | 10 |
| 52385 | AFD 125P60 | 125 | 22.2 | p60 | 250-315 | 10 |
| 52386 | AFD125P80 | 125 | 22.2 | p80 | 200-250 | 10 |
| 52387 | AFD125P100 | 125 | 22.2 | p100 | 125-160 | 10 |



UTILITY KNIVES

Utility Knife



+ 3 extra blades!

| Code | Item No. |
|-------|----------|
| 52392 | GUK197 |



Spare parts and repair kits are available for this product:

Replaceable blades for household utility knife

Code: 52393; Item No.: GUK197SB

HACKSAW

Hacksaw



- Simple and convenient design;
- Ergonomic rubber grip;
- High quality carbon steel cutting blade, 24 teeth per inch.

| Code | Item No. | Blade length, mm |
|-------|----------|------------------|
| 52745 | MHS151 | 150 |

Hacksaw



- Rugged and lightweight frame design;
- Ergonomic rubber grip;
- The upper part of the frame can be used to store spare blades;
- The ability to install the cutting blade under 45° or 90°;
- Bi-metal cutting blade, 24 teeth per inch, hardness up to 64 HRC.

| Code | Item No. | Blade length, mm |
|-------|----------|------------------|
| 52742 | MHS301 | 300 |

Hacksaw



- Rugged and lightweight heavy duty frame design;
- Ergonomic rubber grip;
- The upper part of the frame can be used to store spare blades;
- The ability to install the cutting blade under 45° or 90°;
- Bi-metal cutting blade, 24 teeth per inch, hardness up to 64 HRC.

| Code | Item No. | Blade length, mm |
|-------|----------|------------------|
| 52743 | MHS302 | 300 |

Hacksaw



- Simple and convenient design;
- Ergonomic rubber grip;
- High quality carbon steel cutting blade, 24 teeth per inch;
- Fast change blade mechanism.

| Code | Item No. | Blade length, mm |
|-------|----------|------------------|
| 52744 | MHS303 | 300 |

Spare blades for hacksaws



■ High quality carbon steel cutting blade, 24 teeth per inch.

| Code | Item No. | Blade length, mm | Quantity in a box |
|-------|----------|------------------|-------------------|
| 52748 | MHSB15 | 150 | 10 |
| 52747 | MHSB30 | 300 | 10 |



■ Bi-metal cutting blade, 24 teeth per inch, hardness up to 64 HRC.

| Code | Item No. | Blade length, mm | Quantity in a box |
|-------|----------|------------------|-------------------|
| 52746 | MHSB30BM | 300 | 2 |

DRILLS AND DRILL SETS

TM Thorvik twist metal drill are made from high speed tool steel with a high content of alloying elements, which makes it possible to process materials with high hardness. The geometry of sharpening drills makes it possible to process most well-known materials, such as cast iron, carbon and structural steels, stainless and high-temperature alloys, with high efficiency. TM Thorvik twist drills are manufactured according to DIN 338 type N.

Spiral metal drill HSS

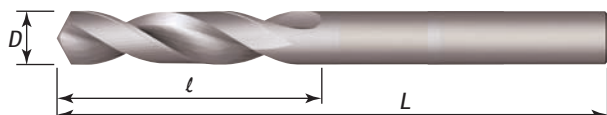

| Code | Item No. | D, mm | L, mm | l, mm | Quantity in a packag |
|-------|----------|-------|-------|-------|----------------------|
| 52394 | TDB010 | 1,0 | 34 | 12 | 10 |
| 52395 | TDB015 | 1,5 | 40 | 18 | 10 |
| 52396 | TDB020 | 2,0 | 49 | 24 | 10 |
| 52397 | TDB025 | 2,5 | 57 | 30 | 10 |
| 52398 | TDB030 | 3,0 | 61 | 33 | 10 |
| 52399 | TDB032 | 3,2 | 65 | 36 | 10 |
| 52400 | TDB035 | 3,5 | 70 | 39 | 10 |
| 52401 | TDB040 | 4,0 | 75 | 43 | 10 |
| 52402 | TDB042 | 4,2 | 75 | 43 | 10 |
| 52403 | TDB045 | 4,5 | 80 | 47 | 10 |
| 52404 | TDB048 | 4,8 | 86 | 52 | 10 |
| 52405 | TDB050 | 5,0 | 86 | 52 | 10 |
| 52406 | TDB055 | 5,5 | 93 | 57 | 10 |
| 52407 | TDB060 | 6,0 | 93 | 57 | 10 |
| 52408 | TDB065 | 6,5 | 101 | 63 | 10 |
| 52409 | TDB070 | 7,0 | 109 | 69 | 10 |
| 52410 | TDB075 | 7,5 | 109 | 69 | 10 |
| 52411 | TDB080 | 8,0 | 117 | 75 | 10 |
| 52412 | TDB085 | 8,5 | 117 | 75 | 5 |
| 52413 | TDB090 | 9,0 | 125 | 81 | 5 |
| 52414 | TDB095 | 9,5 | 125 | 81 | 5 |
| 52415 | TDB100 | 10,0 | 133 | 87 | 5 |
| 52416 | TDB105 | 10,5 | 133 | 87 | 5 |
| 52417 | TDB110 | 11,0 | 142 | 94 | 5 |
| 52418 | TDB115 | 11,5 | 142 | 94 | 5 |
| 52419 | TDB120 | 12,0 | 151 | 101 | 5 |
| 52420 | TDB125 | 12,5 | 151 | 101 | 5 |
| 52421 | TDB130 | 13,0 | 151 | 101 | 5 |

Spiral metal drill HSS TiN in blister

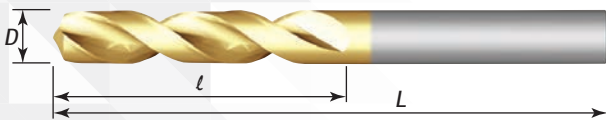
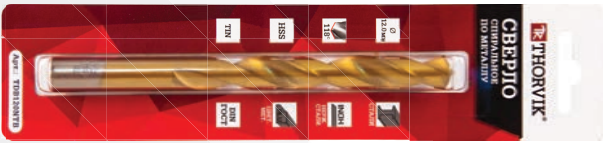
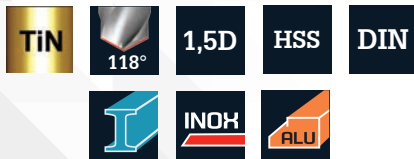

| Code | Item No. | D, mm | L, mm | l, mm | Quantity in a package |
|-------|-----------|-------|-------|-------|-----------------------|
| 52422 | TDB010NTB | 1,0 | 34 | 12 | 2 |
| 52423 | TDB015NTB | 1,5 | 40 | 18 | 2 |
| 52424 | TDB020NTB | 2,0 | 49 | 24 | 2 |
| 52425 | TDB025NTB | 2,5 | 57 | 30 | 2 |
| 52426 | TDB030NTB | 3,0 | 61 | 33 | 1 |
| 52427 | TDB032NTB | 3,2 | 65 | 36 | 1 |
| 52428 | TDB035NTB | 3,5 | 70 | 39 | 1 |
| 52429 | TDB040NTB | 4,0 | 75 | 43 | 1 |
| 52430 | TDB042NTB | 4,2 | 75 | 43 | 1 |
| 52431 | TDB045NTB | 4,5 | 80 | 47 | 1 |
| 52432 | TDB048NTB | 4,8 | 86 | 52 | 1 |
| 52433 | TDB050NTB | 5,0 | 86 | 52 | 1 |
| 52434 | TDB055NTB | 5,5 | 93 | 57 | 1 |
| 52435 | TDB060NTB | 6,0 | 93 | 57 | 1 |
| 52436 | TDB065NTB | 6,5 | 101 | 63 | 1 |
| 52437 | TDB070NTB | 7,0 | 109 | 69 | 1 |
| 52438 | TDB075NTB | 7,5 | 109 | 69 | 1 |
| 52439 | TDB080NTB | 8,0 | 117 | 75 | 1 |
| 52440 | TDB085NTB | 8,5 | 117 | 75 | 1 |
| 52441 | TDB090NTB | 9,0 | 125 | 81 | 1 |
| 52442 | TDB095NTB | 9,5 | 125 | 81 | 1 |
| 52443 | TDB100NTB | 10,0 | 133 | 87 | 1 |
| 52444 | TDB105NTB | 10,5 | 133 | 87 | 1 |
| 52445 | TDB110NTB | 11,0 | 142 | 94 | 1 |
| 52446 | TDB115NTB | 11,5 | 142 | 94 | 1 |
| 52447 | TDB120NTB | 12,0 | 151 | 101 | 1 |
| 52448 | TDB125NTB | 12,5 | 151 | 101 | 1 |
| 52449 | TDB130NTB | 13,0 | 151 | 101 | 1 |

HSS TiN Twist Drill Bit Sets

Set of spiral drills for metal HSS TiN in a plastic case 6 pcs

6 pcs



| Code | Item No. | Quantity in a package |
|--|----------|-----------------------|
| 52478 | TDBS6 | 6 |
| Content: 2.0, 3.0, 4.0, 5.0, 6.0, 8.0 mm | | |

Set of spiral drills for metal HSS TiN in a plastic case 10 pcs

10 pcs



| Code | Item No. | Quantity in a package |
|---|----------|-----------------------|
| 52479 | TDBS10 | 10 |
| Content: 1.0, 2.0, 3.0, 4.0, 5.0, 6.0, 7.0, 8.0, 9.0, 10.0 mm | | |

Set of spiral drills for metal HSS TiN in a metal case 13 pcs

13 pcs



| Code | Item No. | Quantity in a package |
|---|----------|-----------------------|
| 52480 | TDBS13 | 13 |
| Content: 1.5, 2.0, 2.5, 3.0, 3.2, 3.5, 4.0, 4.5, 4.8, 5.0, 5.5, 6.0, 6.5 mm | | |

Set of spiral drills for metal HSS TiN in a metal case 19 pcs

19 pcs



| Code | Item No. | Quantity in a package |
|--|----------|-----------------------|
| 52481 | TDBS19 | 19 |
| Content: 1.0, 1.5, 2.0, 2.5, 3.0, 3.5, 4.0, 4.5, 5.0, 5.5, 6.0, 6.5, 7.0, 7.5, 8.0, 8.5, 9.0, 9.5, 10.0 mm | | |

HSS Co metal twist drill in PVC packaging

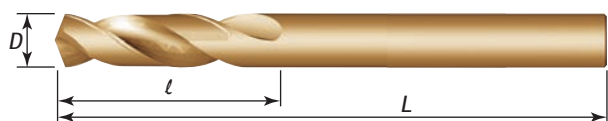

Drill bits $D \geq 13$ mm has shank $\varnothing 13$ mm.

| Code | Item No. | D, mm | L, mm | l, mm | Quantity in a package |
|-------|----------|-------|-------|-------|-----------------------|
| 52450 | TDB010K5 | 1,00 | 34 | 12 | 2 |
| 52451 | TDB015K5 | 1,50 | 40 | 18 | 2 |
| 52452 | TDB020K5 | 2,00 | 49 | 24 | 2 |
| 52453 | TDB025K5 | 2,50 | 57 | 30 | 2 |
| 52656 | TDB028K5 | 2,80 | 61 | 33 | 2 |
| 52657 | TDB029K5 | 2,90 | 61 | 33 | 2 |
| 52454 | TDB030K5 | 3,00 | 61 | 33 | 1 |
| 52658 | TDB031K5 | 3,10 | 65 | 36 | 1 |
| 52455 | TDB032K5 | 3,20 | 65 | 36 | 1 |
| 52659 | TDB033K5 | 3,30 | 65 | 36 | 1 |
| 52660 | TDB034K5 | 3,40 | 70 | 39 | 1 |
| 52456 | TDB035K5 | 3,50 | 70 | 39 | 1 |
| 52661 | TDB036K5 | 3,60 | 70 | 39 | 1 |
| 52662 | TDB037K5 | 3,70 | 70 | 39 | 1 |
| 52663 | TDB038K5 | 3,80 | 75 | 43 | 1 |
| 52664 | TDB039K5 | 3,90 | 75 | 43 | 1 |
| 52457 | TDB040K5 | 4,00 | 75 | 43 | 1 |
| 52665 | TDB041K5 | 4,10 | 75 | 43 | 1 |
| 52458 | TDB042K5 | 4,20 | 75 | 43 | 1 |
| 52666 | TDB043K5 | 4,30 | 80 | 47 | 1 |
| 52667 | TDB044K5 | 4,40 | 80 | 47 | 1 |
| 52459 | TDB045K5 | 4,50 | 80 | 47 | 1 |
| 52668 | TDB046K5 | 4,60 | 80 | 47 | 1 |
| 52669 | TDB047K5 | 4,70 | 80 | 47 | 1 |
| 52460 | TDB048K5 | 4,80 | 86 | 52 | 1 |
| 52670 | TDB049K5 | 4,90 | 86 | 52 | 1 |
| 52461 | TDB050K5 | 5,00 | 86 | 52 | 1 |
| 52671 | TDB051K5 | 5,10 | 86 | 52 | 1 |
| 52672 | TDB052K5 | 5,20 | 86 | 52 | 1 |
| 52673 | TDB053K5 | 5,30 | 86 | 52 | 1 |
| 52674 | TDB054K5 | 5,40 | 93 | 57 | 1 |
| 52462 | TDB055K5 | 5,50 | 93 | 57 | 1 |
| 52675 | TDB056K5 | 5,60 | 93 | 57 | 1 |
| 52676 | TDB057K5 | 5,70 | 93 | 57 | 1 |
| 52677 | TDB058K5 | 5,80 | 93 | 57 | 1 |
| 52678 | TDB059K5 | 5,90 | 93 | 57 | 1 |
| 52463 | TDB060K5 | 6,00 | 93 | 57 | 1 |
| 52679 | TDB061K5 | 6,10 | 101 | 63 | 1 |
| 52680 | TDB062K5 | 6,20 | 101 | 63 | 1 |
| 52681 | TDB063K5 | 6,30 | 101 | 63 | 1 |
| 52682 | TDB064K5 | 6,40 | 101 | 63 | 1 |
| 52464 | TDB065K5 | 6,50 | 101 | 63 | 1 |
| 52683 | TDB066K5 | 6,60 | 101 | 63 | 1 |
| 52684 | TDB067K5 | 6,70 | 101 | 63 | 1 |

| Code | Item No. | D, mm | L, mm | l, mm | Quantity in a package |
|-------|----------|-------|-------|-------|-----------------------|
| 52685 | TDB068K5 | 6,80 | 109 | 69 | 1 |
| 52686 | TDB069K5 | 6,90 | 109 | 69 | 1 |
| 52465 | TDB070K5 | 7,00 | 109 | 69 | 1 |
| 52687 | TDB071K5 | 7,10 | 109 | 69 | 1 |
| 52688 | TDB072K5 | 7,20 | 109 | 69 | 1 |
| 52689 | TDB073K5 | 7,30 | 109 | 69 | 1 |
| 52690 | TDB074K5 | 7,40 | 109 | 69 | 1 |
| 52466 | TDB075K5 | 7,50 | 109 | 69 | 1 |
| 52691 | TDB076K5 | 7,60 | 117 | 75 | 1 |
| 52692 | TDB077K5 | 7,70 | 117 | 75 | 1 |
| 52693 | TDB078K5 | 7,80 | 117 | 75 | 1 |
| 52694 | TDB079K5 | 7,90 | 117 | 75 | 1 |
| 52467 | TDB080K5 | 8,00 | 117 | 75 | 1 |
| 52695 | TDB081K5 | 8,10 | 117 | 75 | 1 |
| 52696 | TDB082K5 | 8,20 | 117 | 75 | 1 |
| 52697 | TDB083K5 | 8,30 | 117 | 75 | 1 |
| 52698 | TDB084K5 | 8,40 | 117 | 75 | 1 |
| 52468 | TDB085K5 | 8,50 | 117 | 75 | 1 |
| 52699 | TDB086K5 | 8,60 | 125 | 81 | 1 |
| 52700 | TDB087K5 | 8,70 | 125 | 81 | 1 |
| 52701 | TDB088K5 | 8,80 | 125 | 81 | 1 |
| 52702 | TDB089K5 | 8,90 | 125 | 81 | 1 |
| 52469 | TDB090K5 | 9,00 | 125 | 81 | 1 |
| 52703 | TDB091K5 | 9,10 | 125 | 81 | 1 |
| 52704 | TDB092K5 | 9,20 | 125 | 81 | 1 |
| 52705 | TDB093K5 | 9,30 | 125 | 81 | 1 |
| 52706 | TDB094K5 | 9,40 | 125 | 81 | 1 |
| 52470 | TDB095K5 | 9,50 | 125 | 81 | 1 |
| 52707 | TDB096K5 | 9,60 | 125 | 81 | 1 |
| 52708 | TDB097K5 | 9,70 | 133 | 87 | 1 |
| 52709 | TDB098K5 | 9,80 | 133 | 87 | 1 |
| 52710 | TDB099K5 | 9,90 | 133 | 87 | 1 |
| 52471 | TDB100K5 | 10,00 | 133 | 87 | 1 |
| 52711 | TDB101K5 | 10,10 | 133 | 87 | 1 |
| 52712 | TDB102K5 | 10,20 | 133 | 87 | 1 |
| 52713 | TDB103K5 | 10,30 | 133 | 87 | 1 |
| 52714 | TDB104K5 | 10,40 | 133 | 87 | 1 |
| 52472 | TDB105K5 | 10,50 | 133 | 87 | 1 |
| 52715 | TDB106K5 | 10,60 | 133 | 87 | 1 |
| 52716 | TDB107K5 | 10,70 | 142 | 94 | 1 |
| 52717 | TDB108K5 | 10,80 | 142 | 94 | 1 |
| 52718 | TDB109K5 | 10,90 | 142 | 94 | 1 |
| 52473 | TDB110K5 | 11,00 | 142 | 94 | 1 |
| 52719 | TDB111K5 | 11,10 | 142 | 94 | 1 |
| 52720 | TDB112K5 | 11,20 | 142 | 94 | 1 |
| 52721 | TDB113K5 | 11,30 | 142 | 94 | 1 |
| 52722 | TDB114K5 | 11,40 | 142 | 94 | 1 |
| 52474 | TDB115K5 | 11,50 | 142 | 94 | 1 |
| 52723 | TDB116K5 | 11,60 | 142 | 94 | 1 |
| 52724 | TDB117K5 | 11,70 | 142 | 94 | 1 |
| 52725 | TDB118K5 | 11,80 | 142 | 94 | 1 |
| 52726 | TDB119K5 | 11,90 | 151 | 101 | 1 |
| 52475 | TDB120K5 | 12,00 | 151 | 101 | 1 |
| 52727 | TDB121K5 | 12,10 | 151 | 101 | 1 |
| 52728 | TDB122K5 | 12,20 | 151 | 101 | 1 |
| 52729 | TDB123K5 | 12,30 | 151 | 101 | 1 |
| 52730 | TDB124K5 | 12,40 | 151 | 101 | 1 |
| 52476 | TDB125K5 | 12,50 | 151 | 101 | 1 |
| 52731 | TDB126K5 | 12,60 | 151 | 101 | 1 |
| 52732 | TDB127K5 | 12,70 | 151 | 101 | 1 |
| 52733 | TDB128K5 | 12,80 | 151 | 101 | 1 |
| 52734 | TDB129K5 | 12,90 | 151 | 101 | 1 |
| 52477 | TDB130K5 | 13,00 | 151 | 101 | 1 |
| 52735 | TDB140K5 | 14,00 | 160 | 108 | 1 |
| 52736 | TDB150K5 | 15,00 | 169 | 114 | 1 |
| 52737 | TDB160K5 | 16,00 | 178 | 120 | 1 |
| 52738 | TDB170K5 | 17,00 | 184 | 125 | 1 |
| 52739 | TDB180K5 | 18,00 | 191 | 130 | 1 |
| 52740 | TDB190K5 | 19,00 | 198 | 135 | 1 |
| 52741 | TDB200K5 | 20,00 | 205 | 140 | 1 |



Set of spiral drills for metal HSS Co

13 pcs



19 pcs



25 pcs



| Code | Item No. | Quantity in a package |
|---|----------|-----------------------|
| 52897 | TDBS13K5 | 13 |
| Content: 1.5, 2, 2.5, 3, 3.5, 4, 4.5, 5, 5.5, 6, 6.5 mm | | |

| Code | Item No. | Quantity in a package |
|--|----------|-----------------------|
| 52898 | TDBS19K5 | 19 |
| Content: 1, 1.5, 2, 2.5, 3, 3.5, 4, 4.5, 5, 5.5, 6, 6.5, 7, 7.5, 8, 8.5, 9, 9.5, 10 mm | | |

| Code | Item No. | Quantity in a package |
|--|----------|-----------------------|
| 52899 | TDBS25K5 | 25 |
| Content: 1, 1.5, 2, 2.5, 3, 3.5, 4, 4.5, 5, 5.5, 6, 6.5, 7, 7.5, 8, 8.5, 9, 9.5, 10, 10.5, 11, 11.5, 12, 12.5, 13 mm | | |

THREADING

Die D-COMBO round, for hand use

| | | | |
|------|--------------|---|----|
| M/MF | HSS-G | R | 6g |
| | DIN EN 22568 | | |

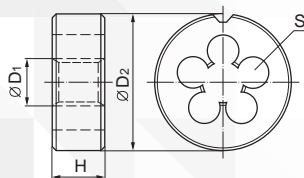

| Code | Item No. | Thread | D1, mm | D2, mm | H, mm | S | kg | pcs | kg |
|--------|----------|-----------|--------|--------|-------|---|-------|-----|------|
| 52828 | MD305 | M3x0.5 | 3,0 | 20,0 | 5,0 | 4 | 0,01 | 200 | 2,4 |
| 52829 | MD407 | M4x0.7 | 4,0 | 20,0 | 5,0 | 4 | 0,008 | 200 | 2,1 |
| 52830 | MD508 | M5x0.8 | 5,0 | 20,0 | 7,0 | 4 | 0,012 | 200 | 2,8 |
| 52831 | MD61 | M6x1.0 | 6,0 | 20,0 | 7,0 | 4 | 0,01 | 200 | 2,5 |
| 52832 | MD71 | M7x1.0 | 7,0 | 25,0 | 9,0 | 4 | 0,026 | 280 | 7,7 |
| 52833 | MD81 | MF8x1.0 | 8,0 | 25,0 | 9,0 | 4 | 0,025 | 280 | 7,6 |
| 52834 | MD8125 | M8x1.25 | 8,0 | 25,0 | 9,0 | 4 | 0,025 | 280 | 7,6 |
| 52835 | MD101 | MF10x1.0 | 10,0 | 30,0 | 11,0 | 4 | 0,037 | 280 | 10,4 |
| 052836 | MD10125 | MF10x1.25 | 10,0 | 30,0 | 11,0 | 4 | 0,037 | 280 | 10,8 |
| 52837 | MD1015 | M10x1.5 | 10,0 | 30,0 | 11,0 | 4 | 0,038 | 280 | 11 |
| 52838 | MD12125 | MF12x1.25 | 12,0 | 38,0 | 10,0 | 4 | 0,058 | 40 | 2,8 |
| 52839 | MD1215 | MF12x1.5 | 12,0 | 38,0 | 10,0 | 4 | 0,058 | 40 | 2,8 |
| 52840 | MD12175 | M12x1.75 | 12,0 | 38,0 | 14,0 | 4 | 0,08 | 40 | 3,7 |
| 52841 | MD14125 | MF14x1.25 | 14,0 | 38,0 | 10,0 | 4 | 0,058 | 40 | 2,8 |
| 52842 | MD1415 | MF14x1.5 | 14,0 | 38,0 | 10,0 | 4 | 0,058 | 40 | 2,8 |
| 52843 | MD142 | M14x2.0 | 14,0 | 38,0 | 14,0 | 4 | 0,08 | 40 | 3,7 |
| 52844 | MD1615 | MF16x1.5 | 16,0 | 45,0 | 14,0 | 4 | 0,108 | 40 | 4,8 |

Die set D-COMBO round, for hand use M3-M12, HSS

8 pcs.



| Code | Item No. | kg | pcs | kg |
|---|----------|------|-----|------|
| 52885 | MDS8 | 0,45 | 50 | 23,5 |
| Content: | | | | |
| Dies III25x9 mm, 7 pcs.: M3, M4, M5, M6, M8 (MD8125), M10, M12; | | | | |
| Dies-holder (DH259); | | | | |
| Metal case. | | | | |

3 pass taps and round dies set COMBO M3-M12, HSS-G, for hand use

32 pcs.



| Code | Item No. | kg | pcs | kg |
|-------|----------|------|-----|------|
| 52887 | MTDS32 | 1,47 | 10 | 15,7 |

Content:
 Sets (3 pcs.) three-way taps, 7 pcs.: M3, M4, M5, M6, M8, M10, M12;
 Taps holder M1-M12 (art.TH1);
 Dies III25x9 mm, 7 pcs.: M3, M4, M5, M6, M8 (MD8125), M10, M12;
 Dies holder (DH259);
 Slotted screwdriver;
 Thread gauge;
 Metal case.

Die D-DRIVE round, for hand use

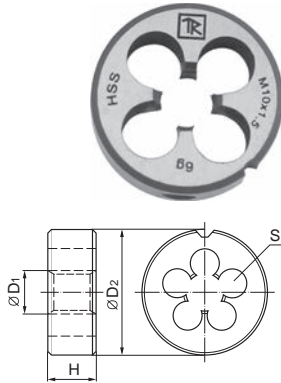

| | | | | | |
|---|-----|---|----|--------------|-----|
| M | HSS | R | 6g | DIN EN 22568 | 60° |
|---|-----|---|----|--------------|-----|

| Code | Item No. | Thread | D1, mm | D2, mm | H, mm | S | kg | pcs | kg |
|-------|----------|---------|--------|--------|-------|---|-------|-----|------|
| 52859 | MDG305 | M3x0.5 | 3,0 | 25,0 | 9,0 | 4 | 0,056 | 200 | 11,6 |
| 52860 | MDG407 | M4x0.7 | 4,0 | 25,0 | 9,0 | 4 | 0,056 | 200 | 11,6 |
| 52861 | MDG508 | M5x0.8 | 5,0 | 25,0 | 9,0 | 4 | 0,053 | 200 | 11 |
| 52862 | MDG61 | M6x1.0 | 6,0 | 25,0 | 9,0 | 4 | 0,054 | 200 | 11,2 |
| 52863 | MDG8125 | MF8x1.0 | 8,0 | 25,0 | 9,0 | 4 | 0,049 | 200 | 10,2 |
| 52864 | MDG1015 | M10x1.5 | 10,0 | 25,0 | 9,0 | 4 | 0,048 | 200 | 10 |

2 pass taps set T-COMBO, 2 pcs for hand use

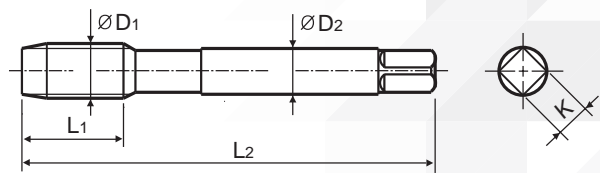

| | | |
|----------|-------|---------|
| M/MF | HSS-G | 2D |
| R | 6H | DIN 352 |
| FORM A/C | | |
| 60° | | |

| Code | Item No. | Thread | D1, mm | D2, mm | L1, mm | L2, mm | K, mm | kg | pcs | kg | |
|--------|-----------|-----------|--------|--------|--------|--------|-------|------|-------|-----|-----|
| 052811 | MT305S2 | M3x0.5 | 3,00 | 3,50 | 11,00 | 40,00 | 2,70 | 2,5 | 0,012 | 320 | 3,9 |
| 052812 | MT407S2 | M4x0.7 | 4,00 | 4,50 | 13,00 | 45,00 | 3,40 | 3,3 | 0,016 | 320 | 5,6 |
| 052813 | MT508S2 | M5x0.8 | 5,0 | 6,00 | 16,00 | 50,00 | 4,90 | 4,2 | 0,024 | 320 | 8,2 |
| 052814 | MT61S2 | M6x1.0 | 6,0 | 6,00 | 19,00 | 56,00 | 4,90 | 5,0 | 0,028 | 320 | 9,4 |
| 052815 | MT71S2 | M7x1.0 | 7,0 | 6,00 | 19,00 | 63,00 | 4,90 | 6,0 | 0,043 | 80 | 3,9 |
| 052816 | MT81S2 | MF8x1.0 | 8,0 | 6,00 | 22,00 | 63,00 | 4,90 | 7,0 | 0,041 | 80 | 3,8 |
| 052817 | MT8125S2 | M8x1.25 | 8,0 | 6,00 | 22,00 | 63,00 | 4,90 | 6,8 | 0,043 | 80 | 3,9 |
| 052818 | MT101S2 | MF10x1.0 | 10,0 | 7,00 | 20,00 | 63,00 | 5,50 | 9 | 0,054 | 80 | 4,8 |
| 052819 | MT10125S2 | MF10x1.25 | 10,0 | 7,00 | 24,00 | 70,00 | 5,50 | 8,8 | 0,056 | 80 | 5 |
| 052820 | MT1015S2 | M10x1.5 | 10,0 | 7,00 | 24,00 | 70,00 | 5,50 | 8,5 | 0,056 | 80 | 5 |
| 052821 | MT12125S2 | MF12x1.25 | 12,0 | 9,00 | 22,00 | 70,00 | 7,00 | 10,8 | 0,081 | 80 | 7 |
| 052822 | MT1215S2 | MF12x1.5 | 12,0 | 9,00 | 22,00 | 70,00 | 7,00 | 10,5 | 0,081 | 80 | 7 |
| 052823 | MT12175S2 | M12x1.75 | 12,0 | 9,00 | 28,00 | 75,00 | 7,00 | 10,2 | 0,085 | 80 | 7,5 |
| 052824 | MT14125S2 | MF14x1.25 | 14,0 | 11,00 | 22,00 | 70,00 | 9,00 | 12,8 | 0,133 | 40 | 5,8 |
| 052825 | MT1415S2 | MF14x1.5 | 14,0 | 11,00 | 22,00 | 70,00 | 9,00 | 12,5 | 0,13 | 40 | 5,7 |
| 052826 | MT142S2 | M14x2.0 | 14,0 | 11,00 | 30,00 | 80,00 | 9,00 | 12,0 | 0,143 | 40 | 6,2 |
| 052827 | MT1615S2 | MF16x1.5 | 16,0 | 12,00 | 22,00 | 70,00 | 9,00 | 14,5 | 0,15 | 40 | 6,5 |

3 pass taps set T-COMBO M3-M12, HSS-G 22 pcs for hand use

22 pcs.



| Code | Item No. | kg | pcs | kg |
|--|----------|-------|-----|------|
| 52886 | MTS22 | 0,704 | 25 | 18,6 |
| Content: | | | | |
| Three pass taps, kit 3 pcs., sizes M3, M4, M5, M6, M8, M10, M12; | | | | |
| Adjustable hand tap wrench M1-M12 (item no. TH1); | | | | |
| Metal case. | | | | |

Hand/machine tip T-DRIVE with spiral point for through hole + guide

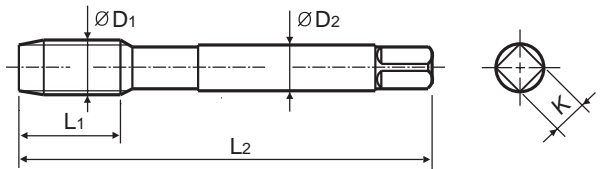

| | | |
|-------------|-----|----|
| M/MF | HSS | 2D |
| R | 6H | |
| DIN 371/374 | 60° | |
| FORM C | | |

| Code | Item No. | Thread | D1, mm | D2, mm | L1, mm | L2, mm | K, mm | kg | pcs | kg |
|--------|------------|----------|--------|--------|--------|--------|-------|------|-------|------|
| 052845 | MTG305SP | M3x0.5 | 3,0 | 3,50 | 11,00 | 40,00 | 2,70 | 2,5 | 0,056 | 11,7 |
| 052846 | MTG407SP | M4x0.7 | 4,0 | 4,50 | 13,00 | 45,00 | 3,40 | 3,3 | 0,057 | 11,8 |
| 052847 | MTG508SP | M5x0.8 | 5,0 | 6,00 | 16,00 | 50,00 | 4,90 | 4,2 | 0,062 | 12,9 |
| 052848 | MTG61SP | M6x1.0 | 6,0 | 6,00 | 19,00 | 56,00 | 4,90 | 5,0 | 0,065 | 13,4 |
| 052849 | MTG8125SP | M8x1.25 | 8,0 | 6,00 | 22,00 | 63,00 | 4,90 | 6,8 | 0,069 | 13,8 |
| 052850 | MTG1015SP | M10x1.5 | 10,0 | 7,00 | 24,00 | 70,00 | 5,50 | 8,5 | 0,095 | 9,7 |
| 052851 | MTG12175SP | M12x1.75 | 12,0 | 9,00 | 28,00 | 75,00 | 7,00 | 10,2 | 0,11 | 11,2 |

Hand/machine tip T-DRIVE, right spiral flute, for blind hole + guide

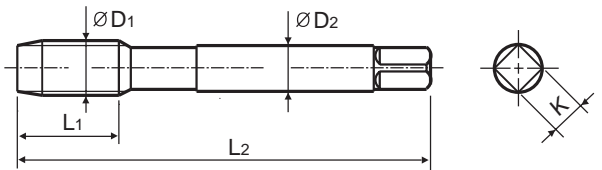

| | | |
|-------------|-------|----------------|
| M/MF | HSS-S | 2D |
| R | 6H | Tilt angle 35° |
| DIN 371/374 | 60° | FORM C |

| Code | Item No. | Thread | D1, mm | D2, mm | L1, mm | L2, mm | K, mm | kg | pcs | kg |
|--------|------------|----------|--------|--------|--------|--------|-------|------|-------|------|
| 052852 | MTG305SF | M3x0.5 | 3,0 | 3,50 | 11,00 | 40,00 | 2,70 | 2,5 | 0,056 | 11,6 |
| 052853 | MTG407SF | M4x0.7 | 4,0 | 4,50 | 13,00 | 45,00 | 3,40 | 3,3 | 0,056 | 11,7 |
| 052854 | MTG508SF | M5x0.8 | 5,0 | 6,00 | 16,00 | 50,00 | 4,90 | 4,2 | 0,061 | 12,7 |
| 052855 | MTG61SF | M6x1.0 | 6,0 | 6,00 | 19,00 | 56,00 | 4,90 | 5,0 | 0,063 | 13 |
| 052856 | MTG8125SF | M8x1.25 | 8,0 | 6,00 | 22,00 | 63,00 | 4,90 | 6,8 | 0,068 | 14 |
| 052857 | MTG1015SF | M10x1.5 | 10,0 | 7,00 | 24,00 | 70,00 | 5,50 | 8,5 | 0,093 | 10 |
| 052858 | MTG12175SF | M12x1.75 | 12,0 | 9,00 | 28,00 | 75,00 | 7,00 | 10,2 | 0,106 | 11,3 |

Adjustable hand tap wrench

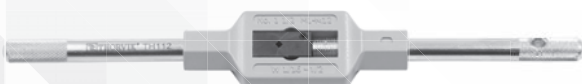

| Code | Item No. | For taps | kg | pcs | kg |
|-------|----------|----------|-------|-----|------|
| 52865 | TH1 | M1-10 | 0,114 | 200 | 23,8 |
| 52866 | TH2 | M4-12 | 0,295 | 60 | 18,7 |
| 52867 | TH3 | M5-20 | 0,626 | 30 | 19,8 |

Adjustable hand tap ratchet wrench



| Code | Item No. | For taps | kg | pcs | kg |
|-------|----------|----------|-------|-----|------|
| 52878 | RTH1 | M3-10 | 0,211 | 60 | 13,7 |
| 52879 | RTH2 | M5-12 | 0,303 | 60 | 19,2 |

Adjustable hand tap ratchet long wrench

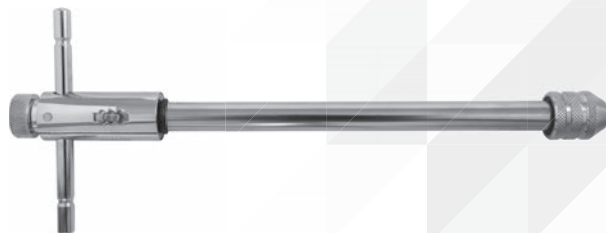

| Code | Item No. | For taps | kg | pcs | kg |
|-------|----------|----------|-------|-----|------|
| 52880 | RTH10 | M3-10 | 0,301 | 60 | 19,1 |
| 52881 | RTH20 | M5-12 | 0,434 | 32 | 14,9 |

Adjustable hand tap wrench, fast lock



| Code | Item No. | For taps | kg | pcs | kg |
|-------|----------|----------|-------|-----|------|
| 52882 | TTH1 | M3-6 | 0,072 | 160 | 12,6 |
| 52883 | TTH2 | M5-8 | 0,1 | 120 | 13 |
| 52884 | TTH3 | M6-12 | 0,158 | 120 | 20 |

Round had die holder



| Code | Item No. | For dies | kg | pcs | kg |
|-------|----------|-----------|-------|-----|------|
| 52868 | DH205 | Ø20x5 mm | 0,089 | 300 | 27,7 |
| 52869 | DH207 | Ø20x7 mm | 0,089 | 300 | 27,7 |
| 52870 | DH259 | Ø25x9 mm | 0,141 | 160 | 23,5 |
| 52873 | DH3810 | Ø38x10 mm | 0,394 | 50 | 20,7 |
| 52871 | DH3011 | Ø30x11 mm | 0,226 | 100 | 23,6 |
| 52872 | DH3814 | Ø38x14 mm | 0,384 | 50 | 20,2 |
| 52874 | DH4514 | Ø45x14 mm | 0,6 | 30 | 19 |

TAPER EXTRACTORS

Screw extractor set



| Code | Item No. | |
|--|-------------------|----------------|
| 52877 | SEA5S | |
| Content: | | |
| M3-M6; M6-M8; M8-M11; M11-M14; M14-M18. | | |
| Plastic case. | | |
| Recommendations for preparing a hole for dismantling a threaded joint | | |
| For thread | Drilling diameter | Drilling depth |
| M3-M6 | 1,8 | 7 |
| M6-M8 | 3,2 | 10 |
| M8-M11 | 4,5 | 13 |
| M11-M14 | 6,5 | 16 |
| M14-M18 | 8,5 | 21 |

Measuring tool

A group of devices and gauges that allow to establish quantitative ratios of any parameters in comparison with a standard is called a measuring tool. These products are mainly used to define geometrical parameters of objects, but can also be associated with the determination of the numerical characteristics of a variety of quantities: mass, induction, spectral.

TM THORVIK® offers its customers products for line and angle measurements such as measuring tape, protractor and torque tools.



TORQUE WRENCHES

Torque wrenches*



| Code | Item No. | Drive size | Working torque, Nm |
|-------|----------|------------|--------------------|
| 52363 | TW14224 | 1/4" DR | 2-24 |
| 52364 | TW381911 | 3/8" DR | 19-110 |
| 52365 | TW122821 | 1/2" DR | 28-210 |

* Wrenches are entered into the Unified State Register of Measuring Instruments (USRS)



Spare parts and repair kits are available for this product:

Torque Wrench Repair Kit for TW14224

Code: 52505; Item No.: TW14224RK

Torque Wrench Repair Kit for TW381911

Code: 52504; Item No.: TW381911RK

Torque Wrench Repair Kit for TW122821

Code: 52503; Item No.: TW122821RK

TORQUE MULTIPLIERS

Labor save wrench



1" DR 1:58 3800 Nm

| Code | Item No. | DR | Gear ratio | Maximum torque, Nm | L, mm | kg |
|-------|----------|----|------------|--------------------|-------|-----|
| 52752 | LSW1 | 1 | 1:58 | 3800 | 270 | 6.5 |

Content: Labor save wrench, handle, HEX L-key, manual and warranty card, plastic case.

Labor save wrench



1" DR 1:58 3800 Nm

| Code | Item No. | DR | Gear ratio | Maximum torque, Nm | L, mm | Extension length, mm | kg |
|-------|----------|----|------------|--------------------|-------|----------------------|------|
| 52753 | LSW2 | 1 | 1:58 | 3800 | 270 | 255 | 7.75 |

Content: Content: Labor save wrench; handle; extension; socket 1"DR: 32, 33 mm; manual and warranty card, plastic case.

Labor save wrench

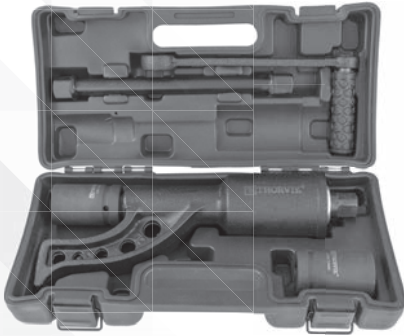

1" DR
1:58
3800 Nm

| Code | Item No. | DR | Gear ratio | Maximum torque, Nm | L, mm | Extension length, mm | kg |
|-------|----------|----|------------|--------------------|-------|----------------------|------|
| 52754 | LSW3 | 1 | 1:58 | 3800 | 310 | 255 | 8.25 |

Content: Labor save wrench; handle; extension; socket 1"DR: 32, 33 mm; manual and warranty card, plastic case.



4 and 6-point flank sockets 1"DR for labor save wrench on [page 18-19](#).

ANGLE GAUGES

Angle gauge



| Code | Item No. |
|-------|----------|
| 52354 | ATAG12 |

MEASURING TAPES

Measuring tape in rubber body



| Code | Item No. | Length, m |
|-------|----------|-----------|
| 52388 | SMT316 | 3 |
| 52389 | SMT519 | 5 |
| 52894 | SMT7525 | 7.5 |
| 52895 | SMT1025 | 10 |

Measuring tape with magnet capture and autostop, rubber body



| Code | Item No. | Length, m |
|-------|-----------|-----------|
| 52390 | SMT316AM | 3 |
| 52391 | SMT519AM | 5 |
| 52896 | SMT7525AM | 7.5 |

THREAD GAUGES

Thread gauges for external threads

20 pcs.

| Code | Item No. |
|-------|----------|
| 52875 | PG20S |

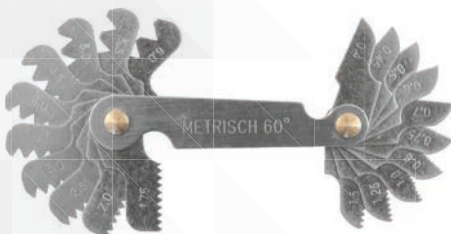

Combined thread gauges for external and internal threads

14 pcs.

| Code | Item No. |
|-------|----------|
| 52876 | PG14SC |



| | |
|--|-------------------|
| Spanners | 1-11 page |
| Combination wrenches and sets of them | 2-3 page |
| Combination wrenches and sets of them. Series ARC | 3-5 page |
| Open end wrenches and sets of them | 5 page |
| Open end wrenches and sets of them. Series ARC | 6-7 page |
| Double ring end wrenches and sets of them | 7 page |
| Double ring end wrenches and sets of them. Series ARC | 8-9 page |
| Double end flare nut wrenches and sets of them | 9 page |
| Double end flare nut wrenches and sets of them. Series ARC | 9-10 page |
| Adjustable wrenches | 10 page |
| Pipe wrenches | 11 page |
| Sockets | 12-18 page |
| Flanksockets 1/4"DR | 13-14 page |
| Flank sockets 1/4"DR | 15-17 page |
| Spark plug sockets | 17 page |
| Flank sockets 1"DR | 17-18 page |
| Handles, universal joints, ratchets | 19-21 page |
| Handles | 20 page |
| Ratchet handles | 20 page |
| Extensions | 21 page |
| Universal joints | 21 page |
| Tool sets | 22-33 page |
| Screwdrivers | 34-37 page |
| Screwdrivers and sets of them | 35-36 page |
| Insulated screwdrivers and sets of them | 37 page |
| Pocket screwdriver 4 in 1 | 37 page |
| Pliers | 38-40 page |
| Combination pliers | 39 page |
| Diagonal cutting pliers | 39 page |
| Long nose pliers | 39 page |
| Box joint pliers | 39 page |
| Internal/external pliers | 40 page |
| Impactor tool | 41-43 page |
| Hammers | 42 page |
| Sledgehammer | 43 page |
| Mallets | 43 page |
| Pneumatic tools | 44-51 page |
| Pneumatic impact wrenches | 45-46 page |
| Air ratchet wrench | 46-47 page |
| Air drill | 47-48 page |
| Air die grinder | 48-49 page |
| Air angle grinders | 49 page |
| Air hammers | 50 page |
| Air blow guns | 50-51 page |
| Air hoses for pneumatic tools | 51 page |
| Automotive tools | 52-61 page |
| Cutting tool | 62-72 page |
| Files and file sets | 63 page |
| Utility knives | 63 page |
| Hacksaw | 64 page |
| Mounted points | 65 page |
| Drills and drill sets | 65-67 page |
| Threading | 68-71 page |
| Disks | 71-72 page |
| Taper extractors | 72 page |
| Measuring tool | 73-75 page |
| Torque wrenches | 74 page |
| Angle gauges | 74-75 page |
| Angle | 75 page |
| Measuring tapes | 75 page |
| Thread Gauges | 75 page |
| The contents | 76 page |

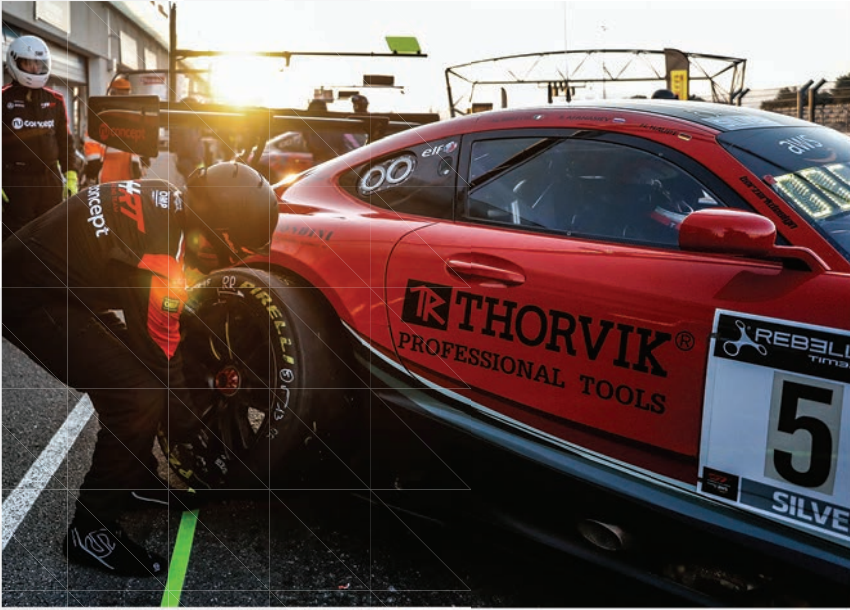

LIFETIME WARRANTY

All THORVIK hand tools are covered by a lifetime warranty against breakage due to defects in materials or workmanship for the expected life of the tool, except as otherwise specified. If you found any defects in a product, return it to the THORVIK distributor where you purchased it.

EXCLUSIONS

- Adapters
- Ordinary wear and tear of normal using (e.g. bits, drill bits, files, saw blades)
- Worn plastic grips and handles
- Tools showing signs of “hammering” damage, abusing, overloading and incorrect using
- Damage from cutting edges or gripping teeth resulting from use on hardened materials

LIMITED TIME WARRANTY

THORVIK warrants tools consisting parts designed to wear such as ratchet handles, ratchet wrenches, pneumatic and hydraulic equipment for a period of one (1) year from date of purchase with proof of purchase, applies to these tools.

For many of tools we offer spare parts to maxims lifetime.

Torque wrenches are designed to be re-calibrated after 1,000 cycles or 1 year (whichever comes first).

This warranty does not cover any problems caused by misuse, abuse, neglect, accidents, modification, poor or incorrect maintenance and improper storage of the tools.



THORVIK®

RELIABLE TOOLS

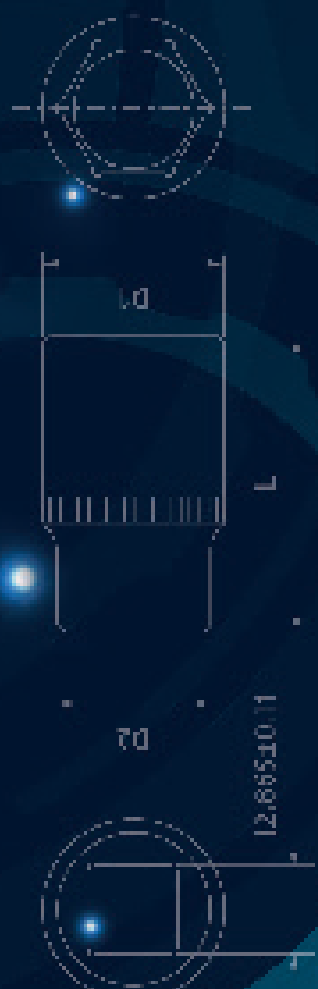
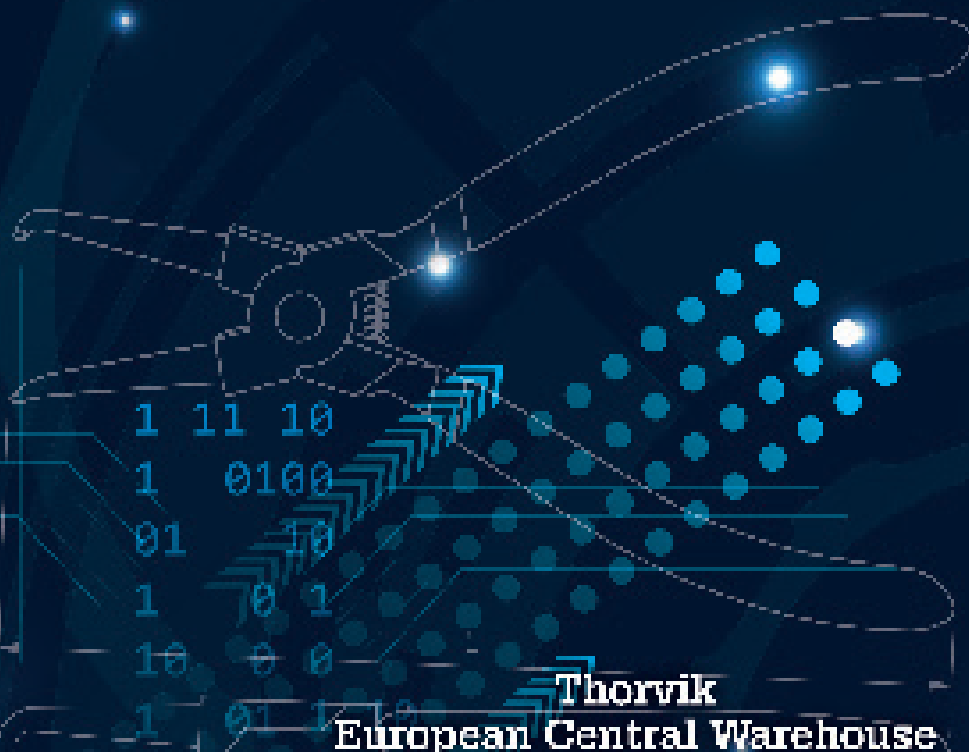

Thorvik

European Central Warehouse

B.A.D.S. JSC

Ateities str. 30G, Kaunas LT-52163

Tel.: (+370 37) 337842

Fax: (+370 37) 337842

E-mail: info@thorviktools.eu

www.thorviktools.eu

1 11 10 01
1 0100 10 011
01 10 1 10
1 0 1 0 0
10 0 0 1 10 01
1 01 1 10